

SMD1204

Stepper Motor Drive



Model	Control(*)	Fieldbus	Peak current	Nominal current
SMD1204xUM	SD / D / SA	-	max. 8,5A	max. 8A
SMD1204xIM	SD / D / SA / M	Modbus RTU		
SMD1204xIC	SD / D / SA / M	CANopen		
SMD1204xIP	SD / D / SA / M	Profibus DP		
SMD1204xIE	SD / D / SA / M	Modbus TCP		
SMD1204xIT	SD / D / SA / M	EtherCAT		
SMD1204xIN	SD / D / SA / M	Profinet		



Notes: * SD = Step/Dir; D = Direct; SA = Stand-Alone; M = Mixed

Electrical characteristics		U.M.	SMD1204Lxx	SMD1204Hxx
Power Supply (HVdc)	Voltage range	Vdc	+24 .. 85	+24 .. 135
	Nominal voltage	Vdc	+65	+120
	Peak current	A	motor current +10%	
Logic Supply (LVdc)	Voltage range	Vdc	+24Vdc +/- 10%	
	Current	A	1	
Output current	Nominal current (sinusoidal)	A _{RMS}	configurable via software max. 8A	
	Peak current	A	max. 8,5A	
	BOOST current	A	max. 8,5A	
Current control	Type		Bipolar PWM	
	Frequency	KHz	20 (50 μs)	
	PWM outputs		Dual MOSFET H-bridges, 20 KHz center-weighted PWM field oriented space-vector modulation	
General purpose digital inputs	Number		10 ^a (vedi nota a)	
	Type		PNP TTL compatible fino a + 30 Vdc	
	"High" / "Low" level threshold	Vdc	+12V default 2,2V threshold configurable through StepControl	
General purpose digital outputs	Number		3+5 ^b (see note a)	
	Type		PNP + 24 VDC	
	Current	mA	100 each channel	
	Protection		Temperature, short-circuit	
Service digital inputs	Number		6 ^a (see note a)	
	Type		PNP TTL compatible up to + 30 Vdc	
	Absorbed current	mA	8	
	"High" / "Low" level threshold	Vdc	+12V default 2,5V threshold if connected in differential	
	Characteristics		High speed inputs (max 70KHz, D.C. 50%)	
Analog input	Number		1+2 ^c (see note c)	
	Resolution	bit	12	
	Range	Vdc	0 .. +10	
Analog output	Number		1	
	Resolution	bit	10	
	Range	Vdc	0 .. +10	

Notes: ^a The general purpose inputs share the same pin-out with the service inputs or the outputs.
^b Outputs with the same pin-out of the service inputs and of the the general purpose inputs.
^c Analog input with the same pin-out of some digital outputs.



Digital inputs and service inputs share the same input pins.

The SMD1204 must be supplied only with DC current, at the voltage specified in the "Models" table.

SMD1204

Stepper Motor Drive

Wiring scheme

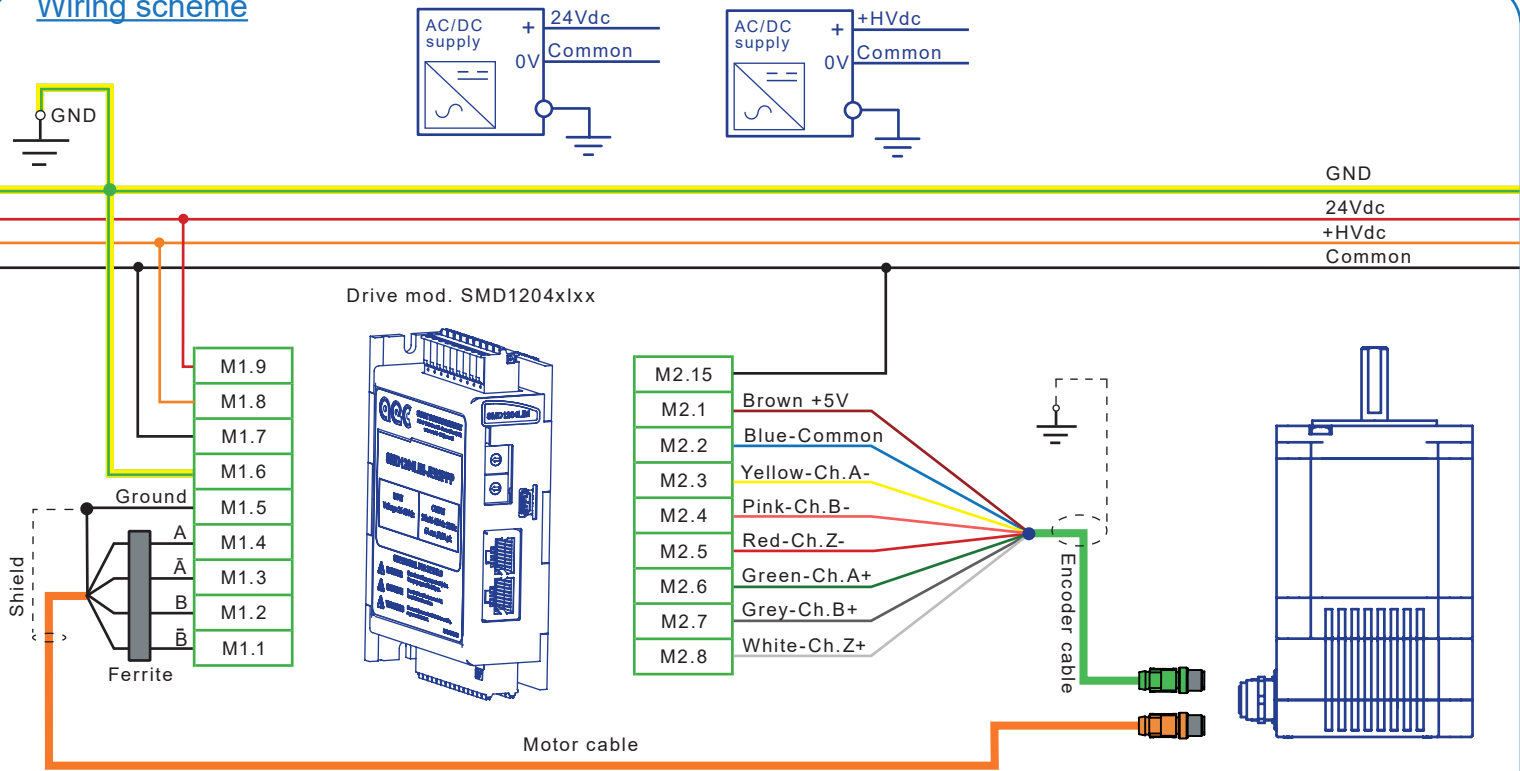

Connect together the commons of power supply and signals present in the terminal blocks.

Terminal blocks

M1		
Pin	Signal name	Description
1	Phase B-	Motor phase B-
2	Phase B	Motor phase B
3	Phase A-	Motor phase A-
4	Phase A	Motor phase A
5	Ground	Ground
6	Ground	Ground
7	Common	DC supplies common reference
8	Power supply	Power stage DC supply input
9	Logic supply	+24Vdc logic stage DC supply input

M2		
Pin	Signal Name	Description
1	+5 Vdc out (max 100mA)	+5 Vdc output (max 100 mA)
2	Common encoder	Encoder inputs common
3	Motor encoder A-	Motor encoder channel A-
4	Motor encoder B-	Motor encoder channel B-
5	Motor encoder Z-	Motor encoder channel Z-
6	Motor encoder A+ / Inp. 5	Motor enc. Channel A+ / Digital input 5
7	Motor encoder B+ / Inp. 6	Motor enc. Channel B+ / Digital input 6
8	Motor encoder Z+ / TOP / Inp. 7	Motor enc. Channel Z+ / TOP input / Digital input 7
9	External encoder A+ / FLS / Input 8	External enc. Channel A+ / Forward Limit Switch / Digital input 8
10	External encoder B+ / BLS / Input 9	External enc. Channel B+ / Backward Limit Switch / Digital input 9
11	External encoder Z+ / Inp. 0	External enc. Channel Z+ / Digital input 0
12	Digital input 1	Digital input 1
13	Digital Output 0	Digital output 0
14	+5 Vdc out (max 100mA)	+5 Vdc output (max 100 mA)
15	Common ground	Comune ingressi/uscite
16	+5 Vdc out (max 100mA)	+5 Vdc output (max 100 mA)
17	Common encoder	Encoder inputs common
18	Digital Output 5	Digital output 5
19	Analog output	Analog output
20	Analog common	Analog in/out common
21	Analog input	Analog input
22	Ana. Inp.1 / Digital Output 2	Analog input 1 / Digital Output 2
23	Ana. Inp.2 / Digital Output 3	Analog input 2 / Digital Output 3
24	External encoder A-	External encoder channel A-
25	External encoder B-	External encoder channel B-
26	External encoder Z-	External encoder channel Z-
27	Digital input 2 / Output 6	Digital input 2 / Digital output 6
28	Digital input 3 / Output 7	Digital input 3 / Digital output 7
29	Digital input 4 / Output 4	Digital input 4 / Digital output 4
30	Digital output 1	Digital output 1



CAUTION:
"Logic supply" +24Vdc

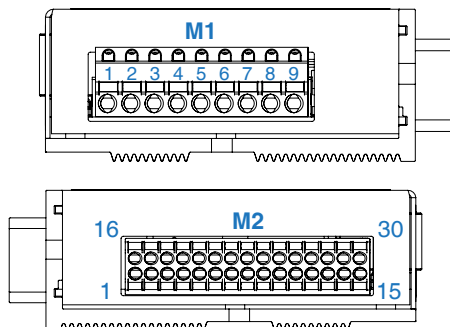

Mechanical dimensions

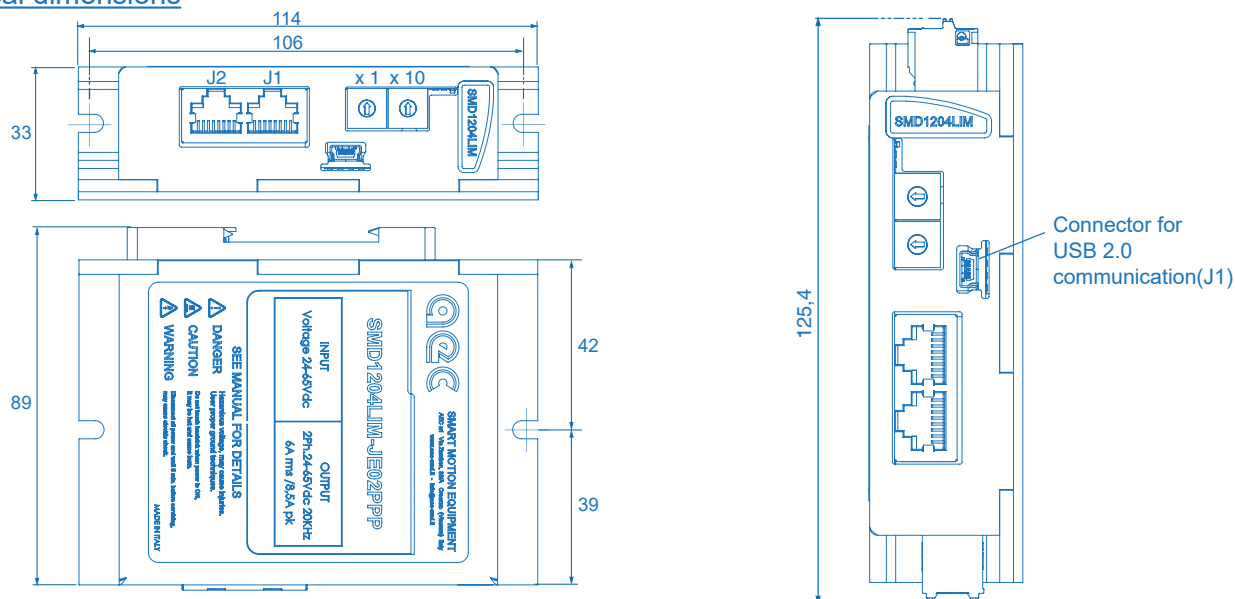

Dimensions are expressed in mm

Status LED indicators

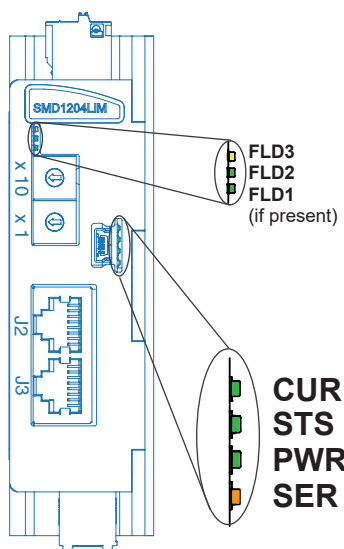

LED name	Color	Description
PWR (Power supply)	Off	The drive is not supplied.
	Green	The logic stage of the drive is supplied.
CUR (Current to the motor)	Off	No current to the motor.
	Green	Nominal current to the motor.
	Orange	Reduced current to the motor.
	Red	BOOST current during the ramps.
STS (Drive status)	Off	Logic stage error.
	Green	Drive is OK.
	Orange	Overtemperature alarm.
	Red (fixed)	Active alarm (check the alarm type with StepControl).
	Red (blinking)	Power stage overvoltage or undervoltage alarm.
SER (Communication)	Off	No Modbus serial communication in progress.
	Orange (blinking)	Modbus serial communication in progress through USB port.
FLD (Fieldbus)		See the manual of the protocol.

Protocol connector

MODBUS RTU (SMD1204xIM-Jxxx)		
RJ45 Female	Pin	Description
 J2 J3 RS232/ RS485 RS485	1	Shield
	2	Data TX (RS-232)
	3	Data RX (RS-232)
	4	Not connected
	5	Common
	6	Not connected
	7	Data + (RS-485)
	8	Data - (RS-485)

CAN-OPEN (SMD1204xIC-Jxxx)		
RJ45 Female	Pin	Description
 J2 J3	1	CAN H Line
	2	CAN L Line
	3	CAN_GND
	4	Reserved
	5	Reserved
	6	CAN Shield
	7	CAN_GND
	8	Reserved

PROFIBUS (SMD1204xIP-Dxxx)		
DB9 Female	Pin	Description
	1	Shield
	2	Reserved
	3	B Line red (positive)
	4	Reserved
	5	DGND (Digital ground)
	6	Out +5V
	7	Reserved
	8	A Line green (negative)
	9	Reserved

IN

OUT

CAUTION: If the mode 8 of the drive is in use (it is possible to verify it with StepControl, register "Rcanmodeofoperation"), it is necessary to set the maximum step resolution, in order to have a smooth and noiseless movement.

P1

P2

For information on slot arrangement, refer to the protocol manual.

7/8" MOTOR CONNECTION CABLE: CONV05FDR7/8Cxxx

Shielded dynamic laying cables with 7/8" female connector, for stepper motors series M86SHxx and M110SHxx.

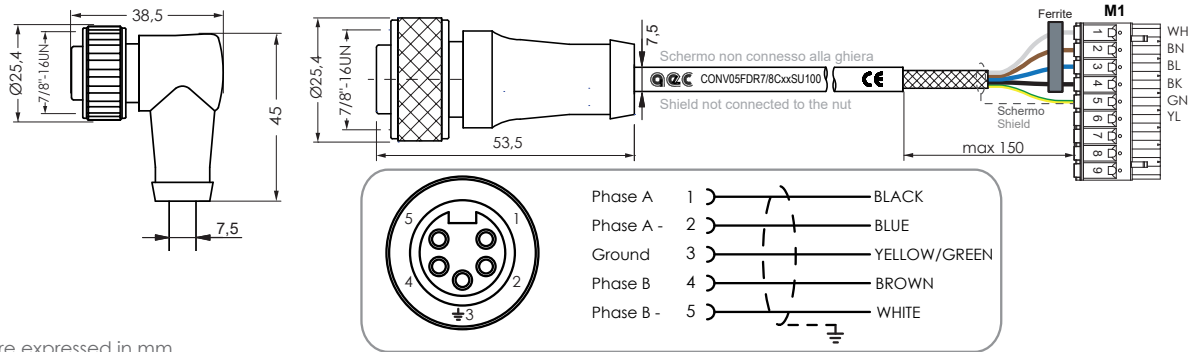

Dimensions are expressed in mm

M12 MOTOR CONNECTION CABLE: CONV05FxxM12Cxxx

Shielded dynamic laying cables with M12 female connector, for stepper motors series M42SHxx, M57SHxx and M60SHxx.

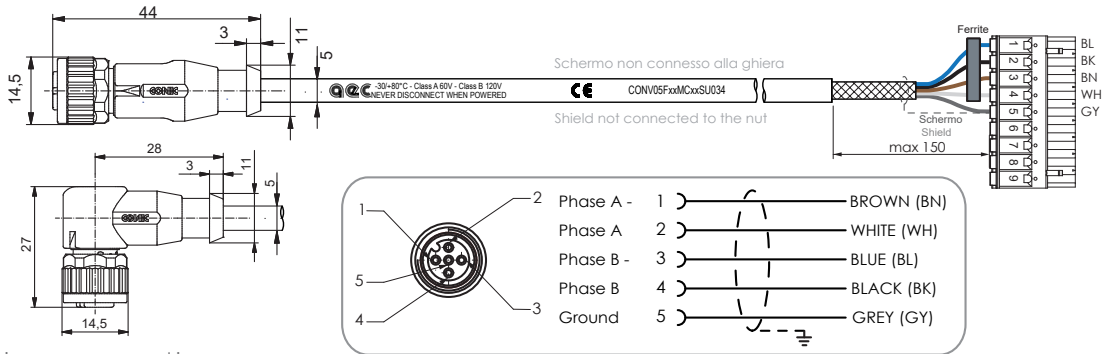

Dimensions are expressed in mm

M12 PUSH PULL ENCODER CONNECTION CABLE: CONV05MxxM12Cxxx

Shielded dynamic laying cables with M12 5 poles male connector, for AEC integrated Push Pull encoders.

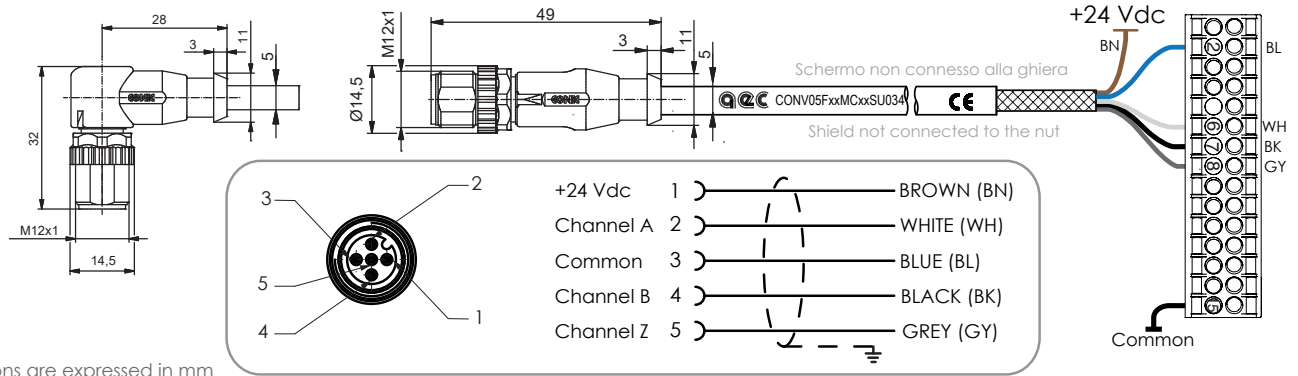

Dimensions are expressed in mm

M12 LINE DRIVER ENCODER CONNECTION CABLE: CONV08FxxM12Cxxx

Shielded dynamic laying cables with M12 8 poles, female connector, for AEC integrated Line Driver encoders.

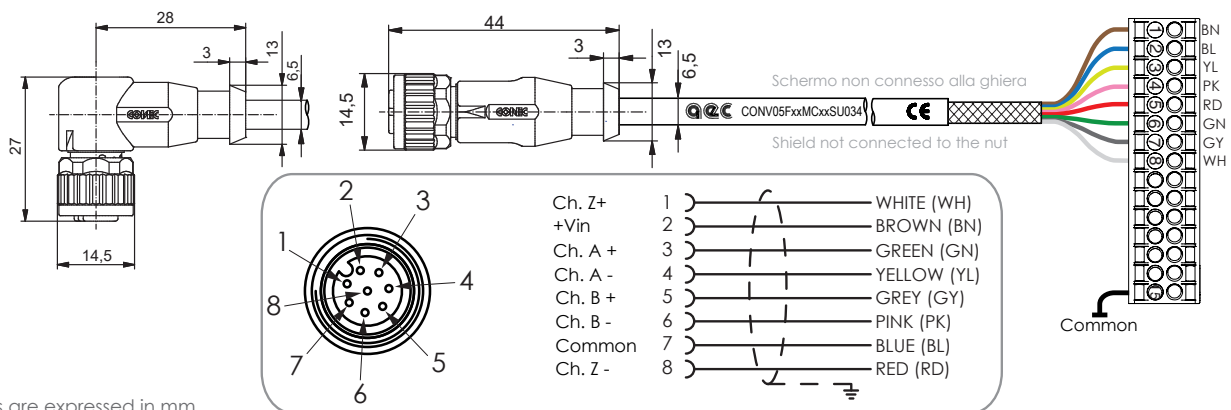

Dimensions are expressed in mm