

User manual

SMD1204xxx *VectorStep* drives





INDEX

INDEX	3
REVISIONS	7
INSTALLATION CONDITIONS	19
DIMENSIONS OF THE DRIVE	20
ABOUT INSTALLATION	21
THERMAL DISSIPATION	22
VELOCITY LOOP	28
TYPES OF POWER SUPPLIES	34
PROTECION FOR THE POWER SUPPLY LINE	41
EARTH CONNECTION, MASS CONNECTION AND SHIELDING	41
SUGGERIMENTI PER LA PREVENZIONE DEI DISTURBI	42
POWER CONNECTOR WIRING	45
INPUTS/OUTPUTS INTERFACE	49
DIGITAL INPUTS	49
SERVICE INPUTS	53
ANALOG OUTPUT	58
CONV05Fxx7/8Cxxx	59
CONV05FxxM12Cxxx	60
CONV05MxxM12Cxxx	61
CONV08FxxM12Cxxx	62
COMMUNICATION INTERFACE	63
RS-232 SERIAL INTERFACE	64
RS-485 SERIAL INTERFACE (SMD1204xxM)	65
CANOPEN INTERFACE (SMD1204xxC)	67
PROFIBUS INTERFACE (SOLO SMD1204xxP)	69
MODBUS TCP/IP INTERFACE (SOLO SMD1204xxE)	71
ETHERCAT INTERFACE (SOLO SMD1204xxT)	72
PROFINET INTERFACE (ONLY SMD2204xIN)	73
STAND-ALONE CONTROL	75
GENERAL CHARACTERISTICS	75
ARCHITECTURE	75
SUPPORTED FUNCTIONS	76
PROGRAMMING METHODS	77
START-UP CONFIGURATION	81
DIRECT CONTROL	82
GENERAL CHARACTERISTICS	82
ARCHITECTURE	83
CONTROL WITH MODBUS RTU	84
GENERAL CHARACTERISTICS	84
SUPPORTED FUNCTIONS	84
ARCHITECTURE	85

COMMUNICATION SPEED	86
ADDRESSING	87
CONTROL WITH CANOPEN	88
GENERAL CHARACTERISTICS	88
SUPPORTED FUNCTIONS	88
SUPPORTED OPERATION MODES	89
ARCHITECTURE	89
COMMUNICATION SPEED	90
ADDRESSING	90
CONTROL WITH PROFIBUS DP	91
GENERAL CHARACTERISTICS	91
SUPPORTED FUNCTIONS	91
ARCHITECTURE	92
COMMUNICATION SPEED	93
ADDRESSING	93
CONTROL WITH MODBUS TCP/IP	94
GENERAL CHARACTERISTICS	94
ARCHITECTURE	95
COMMUNICATION PARAMETERS	96
CONTROL WITH ETHERCAT	98
GENERAL CHARACTERISTICS	98
CONTROL VIA PROFINET	102
CYCLIC AND ACYCLIC SERVICES	102
ACYCLIC READ/WRITE SERVICES	102
ELECTRONIC FILE DESCRIPTION	102
INTRODUCTION TO ACYCLIC COMMUNICATION PROFINET	103
CONFIGURATION SLOT	104
CONTROL THROUGH INPUTS/OUTPUTS	105
GENERAL CHARACTERISTICS	105
SUPPORTED FUNCTIONS	105
PULSE TRAIN CONTROL (STEP AND DIRECTION)	106
POSITIONING FUNCTIONS	107
SPECIAL FUNCTIONS	109
GENERAL CHARACTERISTICS	110
HARDWARE AND SOFTWARE LIMITS	110
LEVEL OF CURRENT	111
MOVEMENT PARAMETERS	111
HOMING PARAMETERS	112
DRIVE GENERAL PARAMETERS	113
GENERAL CHARACTERISTICS	113
CONTROL MODES	113
OPERATION MODE	113
SETTING OF THE CURRENT	114

DRIVE ADVANCED PARAMETERS	115
GENERAL CHARACTERISTICS	115
POSITION LOOP	115
VELOCITY LOOP	116
CURRENT LOOP	116
PHASE ADVANCE	117
MOTOR PARAMETERS	118
GENERAL CHARACTERISTICS	118
ELECTRIC CHARACTERISTICS	118
PHYSICAL CHARACTERISTICS	118
STEP RESOLUTION	119
ENCODER RESOLUTION	119
INPUTS AND OUTPUTS PARAMETERS	120
GENERAL CHARACTERISTICS	120
SERVICE INPUTS	120
DIGITAL INPUTS	120
DIGITAL OUTPUTS	121
ANALOG INPUTS	122
AUXILIARY ENCODER PARAMETERS	125
ALARM PARAMETERS	127
GENERAL CHARACTERISTICS	127
ALARMS CONFIGURATION	127
WARNING CONFIGURATION	128
ALARMS HISTORY	129
COMMUNICATION PARAMETERS	130
MODBUS RTU PARAMETERS (SMD1204xxM)	130
CANOPEN PARAMETERS (SMD1204xxC)	131
PROFIBUS PARAMETERS (SMD1204xxP)	132
MODBUS TCP/IP PARAMETERS (SMD1204xxE)	132
ETHERCAT PARAMETERS (SMD1204xxT)	133
PROFINET PARAMETERS (SMD1204xIN)	133
GENERAL CHARACTERISTICS	134
ROTATION DIRECTION OF THE MOTOR	134
ROTATION DIRECTION OF THE MOTOR ENCODER	134
FUNTIONS ASSOCIATED WITH THE ROTARY SWITCHES	135
ADDRESSING	135
SPECIAL FUNCTIONS	135
FOLLOWING CONTROL	139
GENERAL CHARACTERISTICS	139
PARAMETERS	139
GENERAL CHARACTERISTICS	140
PARAMETERS	140

QUOTA REALIGNMENT	141
GENERAL CHARACTERISTICS	141
PARAMETERS	141
GENERAL CHARACTERISTICS	142
PARAMETERS	143
AUTOMATIC SAVE OF THE POSITION AT THE SHUT-DOWN	144
GENERAL CHARACTERISTICS	144
PARAMETERS	144
LIMIT SWITCHES MANAGEMENT	145
HARDWARE LIMIT SWITCHES	145
SOFTWARE LIMITS	146

REVISIONS

Revision	Date	Notes
	March 2020	First draft
Rev .01	March 2020	General update
Rev. 02	November 2020	Addition of SMD1204H versions
Rev. 03	November 2021	Addition of Profinet protocol

©Copyrights 2019-2021 AEC s.r.l. All rights reserved. Printed in Italy.

COPYRIGHTS

All rights reserved. No part of this publication may be reproduced or distributed in any form or by any means, or stored in a database or retrieval system, without the prior written permission of AEC s.r.l .

We do not accept any liability arising from use of the information contained in this manual.

AEC s.r.l. is constantly trying to improve the quality of its products and the information contained in this manual are subject to change without notice.

Although great care has been exercised in the preparation of this document, however AEC s.r.l. cannot accept any liability whatsoever connected with its use.

TRADEMARKS AND DISCLAIMER

StepControl, StepControl LT, SMD11xxx, SMD12xxx, SMD22xxx, SMD30.xxx, SMD50.xxx, SMD5106xx, SMD5206xxx are registered trademarks of AEC s.r.l.

All third party trademarks (including logos, icons, product names, company names) referenced by AEC remain the property of their respective owners.

Unless specifically identified as such, AEC's use of third party trademarks does not indicate any relationship, sponsorship, or endorsement between AEC and the owners of these trademarks.

All references by AEC to third party trademarks are to identify the corresponding third party goods and/or services and intended to constitute nominative fair use under applicable trademark laws.

SAFETY PRECAUTIONS

Important

In order to avoid damages to machineries and devices, and injuries to the installation staff, it is recommended to follow the instructions below.

In this manual, the following symbols are used to identify warning levels you may occur if you don't follow instructions.



DANGER

Identifies conditions that may cause death or serious injuries if precautions are not observed.



CAUTION

Identifies conditions that may cause injuries, damages to the product or malfunctioning, if precautions are not observed. In some cases, failure to follow precautions may cause serious consequences.

The following symbols identify forbidden and mandatory operations.



FORBIDDEN

Identifies forbidden actions, which must NEVER be done.



MANDATORY

Identifies mandatory actions, which MUST be done.

The following symbols are used to identify important information, which are useful for a correct installation.



IMPORTANT

Identifies important information, included precautions like warnings you should consider in order to avoid to damage the device.



INFORMATION

Identifies additional information.



DANGER

Read full instructions before checking, transporting, stocking, installing, wiring, functioning, inspecting or disposing of the devices.

Make sure that cables and connectors have been connected correctly.



Wrong wiring may cause electric shocks, fire, damages to the devices or injuries.

Do not expose cables to sharp objects or edges, excessive traction or pressure, or to objects that could cause crushing.



Breaking or dispersing cables may cause electric shocks, fire, damages to the device or injuries.

Never touch any rotating part of the motor while drive and motor are operating.

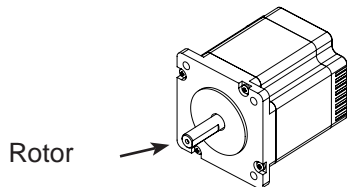

Failure to follow this instruction may cause injuries.

Wait at least 5 minutes after the shut down of the drive before removing or altering wiring, or inspecting device.

This operation must be carried out only by skilled staff.



Failure to follow this instruction may cause electric shocks.

Never touch internal parts of the drive.



Failure to follow this instruction may cause injuries.

Don't remove cables, connectors, protection elements or optionals while power supply is active, or without proper safety systems.



Failure to follow this instruction may cause electric shocks or damages to the devices.

Do not approach the machinery immediately after resetting temporary power drop, to avoid unexpected reboots.



Failure to follow this instruction may cause injuries.

Never touch motor or drive while they are operating.

Their surfaces may reach high temperatures.



Failure to follow this instruction may cause burns

Do not subject the product to water, corrosive liquids, flammable gases or combustible.



Failure to follow this instruction may cause fire

During the installation, must be provided protections against over-current, mass dispersion protections, over temperature protections, as well as emergency stop devices.



In absence of protections, faults may cause electric shocks, fire or injuries.



DANGER

Read full instructions before checking, transporting, stocking, installing, wiring, functioning, inspecting or disposing of the devices.

Strictly follow instructions and procedures included in this manual when checking correct installation.



Malfunctions due to wrong installation may damage devices and may cause accidents or injuries.

Installation, wiring and inspections must be carried out by authorized personnel.



Failure to follow this instruction may cause fire electric shocks, fire, injuries, damages and malfunctions.

Install an emergency stop device on-board the machinery.



Failure to follow this instruction may cause electric shocks, fire or injuries.

Applications and installations must meet all applicable safety requirements.



In absence of protections, faults may cause injuries.

Make sure of proper grounding devices. Connect the grounding terminal, in accordance with the standards for electrical installations. (Mass Resistance $\leq 100\Omega$)



Failure to follow this instruction may cause electric shocks.

Use properly sized equipments for the type of load to be handled.



Failure to follow this instruction may cause damages or injuries.



CAUTION

Do not carry the drive or the motor taking by cables or motor shaft.



Failure to follow this instruction may cause malfunctions or injuries.

Do not apply loads greater than indicated in the technical documentation.



Failure to follow this instruction may cause malfunctions or injuries.

Do not trample. Do not put heavy objects on the product.



Failure to follow this instruction may cause malfunctions or injuries.

- Do not stock or install the product in the following locations:
- Locations subject to temperatures outside the permitted ranges.
- Locations subject to humidity outside the permitted ranges.
- Locations subject to condensation.
- Locations exposed to corrosive, explosive or flammable gases.
- Locations exposed to dust, salt or metal powders agents.
- Places exposed to water, oil or chemicals agents.
- Locations subject to shock or vibration.



Failure to follow this instruction may cause malfunctions or damages of the product.

Do not cover inputs, outputs and ventilation slots of the drive. Prevent foreign objects such as metal fragments or liquids from entering the product.



Failure to follow this instruction may cause deterioration of internal components and malfunctions

AEC drives are precision devices. Prevent shocks during transport, installation and function.



Failure to follow this instruction may cause malfunctions

Supply the drive only with insulated voltages from main power supply, inside the allowed range.



Failure to follow this instruction may cause malfunctions, fire or electric shocks.

Make sure that the drive is correctly connected.



Failure to follow this instruction may cause malfunctions, fire or electric shocks.

Keep specified distances between the drive and other devices.



Failure to follow this instruction may cause malfunctions fire.

In the case of use in vertical axes, install safety devices to prevent possible falls of parts in case of emergency or fault.



Failure to follow this instruction may cause malfunctions or injuries.

Safely connect the power supply terminals. Use cables of proper section for their use.



Failure to follow this instruction may cause fire.

Keep supply lines and signal lines at a distance of at least 300 mm.

Use twisted pairs or shielded cables.



Failure to follow this instruction may cause malfunctions.

Functioning tests must be carried out only with motor shaft disconnected from the machinery.



Failure to follow this instruction may cause serious injuries.

When an alarm occurs, turn the power off, remove the cause that triggered the alarm.

Make sure that system is safe before turn the power.



Failure to follow this instruction may cause injuries.

Make sure to meet all installation conditions



Failure to follow this instruction may cause malfunctions, fire or electric shocks.



Consider these products as general industrial waste when disposing them.

NOTES ON SAFETY

Products for automation manufactured by AEC must be handled, installed and maintained only by skilled and authorized personnel, that must be qualified and instructed to install components for automation. Devices must be installed only for the purposes described in the user's guide. The installer should pay particular attention to potential risks caused by mechanical and electrical hazards.

It is very important that all applications and installations meet all applicable safety requirements.

The installers must take responsibility to verify their knowledge and understanding of all applicable safety standards.

Installations which are not complying with safety requirements can damage equipment and injure the user.

AEC s.r.l. will not be liable and will not take any responsibility for damages caused by products handled or installed improperly, or if the customer have given permission or performed modifications and/or repairs not authorized from AEC s.r.l.

AEC's motion control equipment are high-performances devices for automation, able to producing high forces and rapid movements.

Pay high attention, in particular during installation and development of applications.

Use properly sized equipments for the type of application.

AEC's devices must be considered as components for automation. They are sold as end-user products, and must be installed only by qualified personnel, in accordance with all applicable safety requirements.

Skilled staff must be able to recognize possible dangers that may result from programming, modifying parameter's values and, generally, that may result from using mechanical, electric and electronic equipment.

The drive must be installed in closed cabinets, so that any parts thereof is not reachable while system is powered on.

AEC s.r.l strongly recommends to always follow safety requirements and security rules. Failure to follow this instruction may cause and/or injuries.

General precautions

- The images contained in this manual are for demonstration purposes, and may differ from the products received.
- This manual is subject to changes due to improvement of the products, modification of specifications, or manual thereof improvement.
- AEC s.r.l. is not responsible for any damage to property or injury that could result from improper installation and/or not authorized modification to products.



*AEC's drive systems are are products for general use that conform to the state of the art in technology and are designed to prevent any dangers. However, drives and drive controllers that are not specifically designed for safety functions are not approved for applications where the functioning of the drive could endanger persons. **The possibility of unexpected or unbraked movements can never be totally excluded without additional safety equipment.** For this reason personnel must never be in the danger zone of the drives unless additional suitable safety equipment prevents any personal danger. This applies to operation of the machine during production and also to all service and maintenance work on drives and the machine. The machine design must ensure personal safety. Suitable measures for prevention of property damage are also required.*



To prevent personal injury and damage to property, damaged drive systems must not be installed. Changes and modifications of the drive systems are not permitted, and if made all no warranty and liability will be accepted.

MAINTENANCE AND INSPECTION

To ensure a proper and satisfactory performance of the drives and the motors, equipments and installations need periodic inspections and checks.

Notes for maintenance personnel

After shutdown, the internal capacity will remain charged, at high voltages, for a short period of time. Wait at least 10 minutes after PWR led goes off, before working on the device.

Drives and motors can reach high temperatures during functioning, therefore it is recommended to wait for them to cool before touching any of their surfaces. In all cases, be careful.

Never plug or unplug any connector when power is connected.

Control cycles checklist

Correct operating conditions:

Operating temperature : 30° C (annual average)

Hours of work : 24 hours per day

Periodically check the correct operation of the equipments by following this checklist:

Type of inspection	Frequency	Checklist
Weekly check	Weekly	<ol style="list-style-type: none">1. Operating temperature, humidity, dust, particles or foreign matter2. Vibrations or not standard noises3. Main and auxiliary supply voltage4. Odors5. Obstruction of ventilation slots6. Cleaning of drive and connectors7. Correct insertion of connectors8. Integrity of the cables
Periodically check	Annual	<ol style="list-style-type: none">1. Verify the correct closure of the fixing screws2. Signal malfunction or overheating

In case that operating conditions are different from the recommended ones, carry out inspections more frequently.

BEFORE USE

This chapter contains general informations about operations to be carried out when receiving products, and before the installation of the drives and axis controllers for stepping motors manufactured by AEC s.r.l.

PRODUCTS VERIFICATION

Upon receipt of the goods, verify that the product received is the ordered one, by checking that order code corresponds with ID label code.

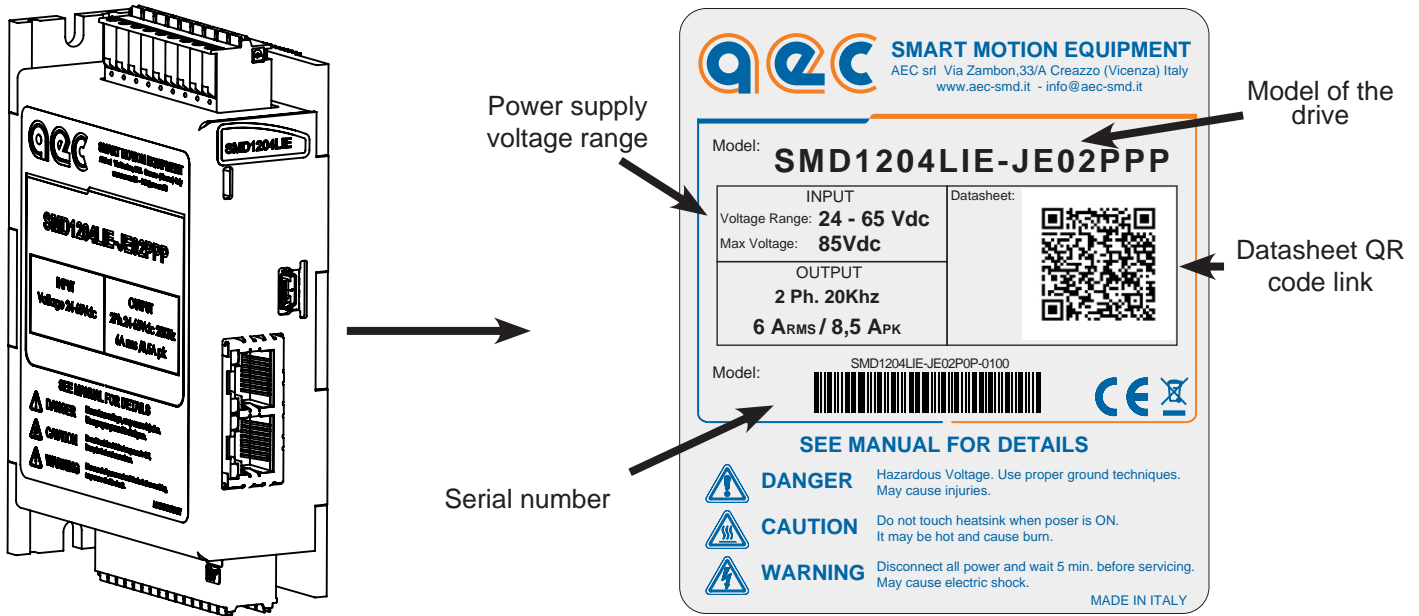

MODEL CODE

SMD 1204 L I E - J E 0 2 P P P

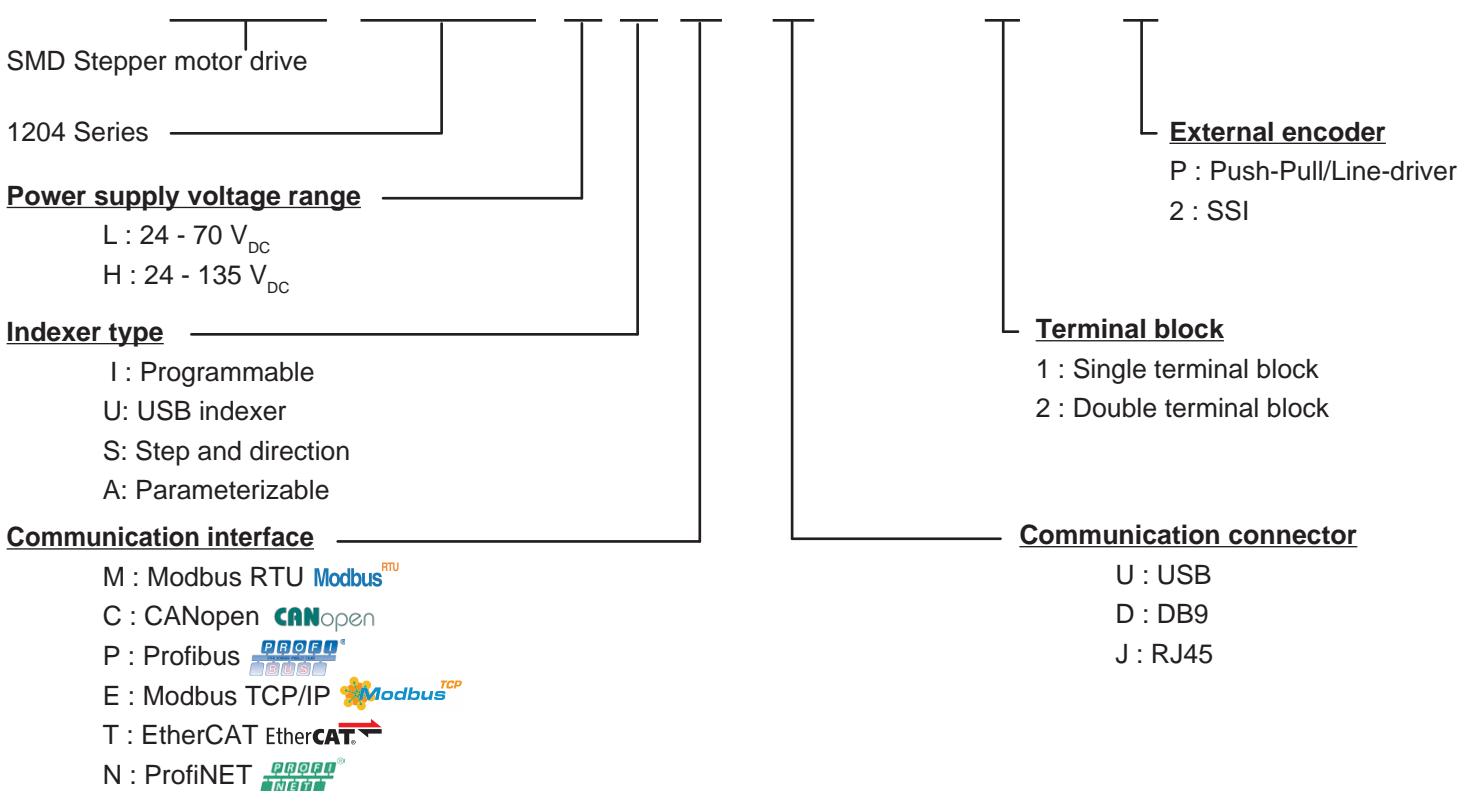

COMPONENTS IDENTIFICATION

Top view

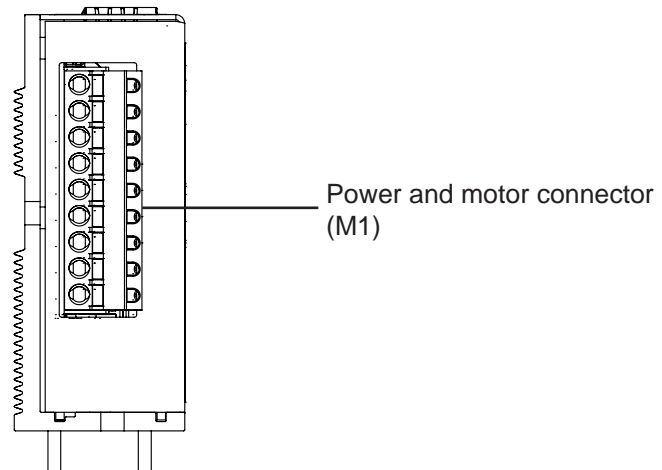

Bottom view

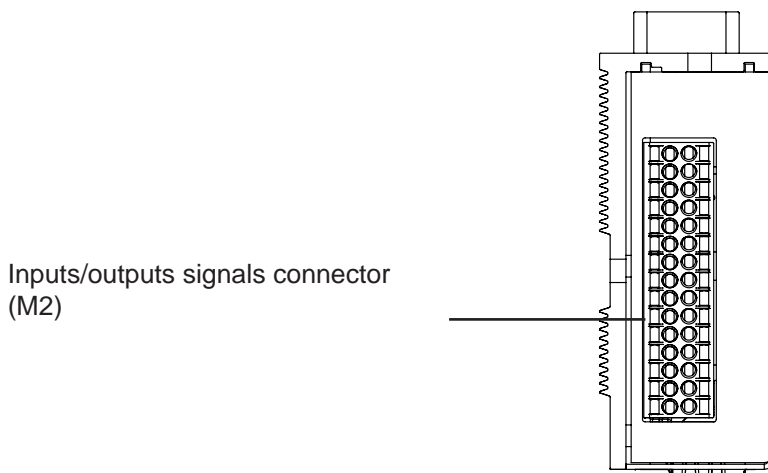

Front view

Fieldbus connector (Modbus RTU / Profibus DP / CANopen / Modbus TCP-IP / EtherCAT / Profinet)

Rotary switches for communication address setting (SW1-2)

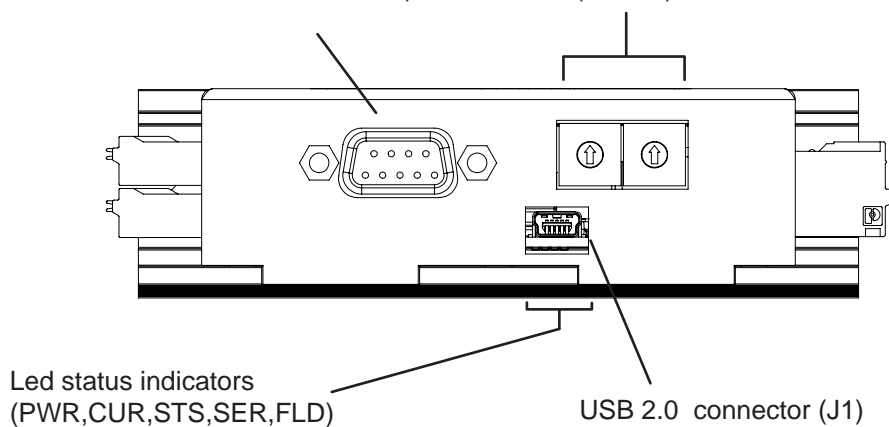

Address setting

With SW1 and SW2 rotary switches you can set communication address of all communication protocols (Modbus RTU, CANopen, Profibus DP). Modifications will be effective at the first reactivation of power supply.

APPLICABLE STANDARDS

European directives



Our drives comply with the following directives:

Low voltage directive 2014/35/UE

Standard EN 61800-3: 2004

*Adjustable speed electrical power drive systems -
Safety requirements – Electrical, thermal and energy*

EMC Directive 2014/30/UE

Standard EN 61800-5-1:2007

*Adjustable speed electrical power drive systems -
Part 3: EMC requirements and specific test methods*

Note:

In order to comply with the directives mentioned above, the drives must be installed in accordance with the instructions described in the user manual of the product.

Since the drives are installed into a system, they need a new confirmation of compliance after the installation.

Since the drives are components to be incorporated into a machinery, it is necessary to verify that the complete machinery comply with the requirements of the current machinery directive before putting it in service.

STEPPER MOTOR DRIVE

The SMD1204xxx is a full-digital drive for stepping motor. It can operate in three modes of control: stepper-mode, smart-mode or servo-mode.

The SMD1204xxx can work in stand-alone mode, or connected to a Modbus RTU, Modbus TCP/IP, Profibus DP, CANopen, EtherCAT or Profinet communication network.

In stand-alone mode, the drive can generate complex profiles, controlled by the integrated user program, it can handle inputs and outputs, receive data or commands by a communication bus.

If connected to a communication network, it can be totally controlled by an host computer, or it can work in mixed mode.

The drive SMD1204xxx must be supplied with a DC voltage obtained from a switching power supply or by rectifying and filtering the secondary of a transformer.

The drive features a useful function that allows to keep “alive” the axis controller even if the motor stage isn’t supplied.

Stepper-mode

In stepper-mode, the drive works in open loop with a stepless regulation of the current that permits to obtain an evolved and optimized vector control.

The system allows to adapt to load conditions, and to drastically reduce thermal dissipation and mechanical resonances. The result is a smooth and silent movement, thanks to the sinusoidal current management, free from parasitic harmonics.

Smart-mode

In smart-mode, the stepper motor works as a servo-motor controlled in closed loop.

The drive uses the encoder to maintain the position and the velocity of the motor, modifying the driving parameters in order to follow the theoretic profiles to be executed.

The supply of the current during the movement is constant at the nominal level. While the motor is in standstill, the current is brought to the reduced current level, in order to maintain the position.

The drive can be configured to work in current loop, velocity loop or torque loop.

Servo-mode

In servo-mode, the stepper motor works as a real servo-motor controlled in closed loop.

The drive uses the encoder to maintain the position and the velocity of the motor, modifying the driving parameters in order to follow the theoretic profiles to be executed. Unlike smart-mode, the supply of the current is not a constant level, but varies depending on the error breadth and the requested torque. This reduces the thermal dissipation and the energetic consumption of the system.

The drive can be configured to work in current loop, velocity loop or torque loop.

CONFIGURATION WITH STEPCONTROL

The configuration of the SMD1204xxx is very easy and intuitive with the software StepControl.

The drive communicates with the PC with a USB 2.0 connection. All of the parameters and registers can be configured through software.

It is possible to adjust manually all of the parameters of the drive, in order to obtain the highest performances, even in particularly difficult conditions.

The drive configuration can be saved in a file, duplicated and loaded to other drives, in order to make easier to configure further axis.

With StepControl you can display graphics and charts showing register or internal variable's datas, you can display warnings and alarms which may occur, or control the axis with the manual console.

COMMUNICATIONS AND FIELDBUS

It is possible to assign a communication address to the drive, in order to connect more drives into the same communication network.

The SMD1204xxx drive series supports the following communication bus:

1. Modbus RTU
2. Modbus TCP/IP
3. CANopen
4. Profibus
5. EtherCAT
6. Profinet

Modbus^{RTU}

 **Modbus**^{TCP}

CANopen[®]

EtherCAT[®]

PROFINET[®]

INSTALLATION CONDITIONS

Characteristic		Specification
Operating temperature		0°C ... +50°C
Cooling		Ventilate the drive in case of continuous operation
Operating humidity		95% RH or less (no condensation)
Stocking temperature		-20°C ... +70°C
Stocking humidity		95% RH or less (no condensation)
Installation location		Free of corrosive gases Free of dust and iron dust Not subject to humidity or oil lubricant such as cutting oil
Altitude		1.000 m or less
Vibration resistance		4,9 m/s ²
Shock resistance		19,6 m/s ²
Operating conditions		Installation category (overvoltage category): III Pollution degree: 2 or better Protection class: IP3X (EN50178)
Installation location	Installation in a control panel	Design the control panel dimensions, the module layout and cooling method so that the temperature in proximity of the drive does not exceed 50°C. Note: In order to increase product lifespan and ensure reliability, we advise to keep the temperature inside the control panel below 40°C.
	Installation in proximity of a heating module	Minimize the thermal radiations coming from the heating module and any increases in temperature caused by natural convection, in order to ensure that the temperature in proximity of the drive does not exceed 55°C
	Installation in proximity of a source of vibration	Install a vibration dampener under the drive, in order to avoid to subject the device to excessive vibrations.
	Installation in a location subject to corrosive gases	Corrosive gases do not have an immediate effect over the drive, but in the long terms, they cause electronic components malfunctions. Take appropriate measures in order to prevent corrosive gases presence.

DIMENSIONS OF THE DRIVE

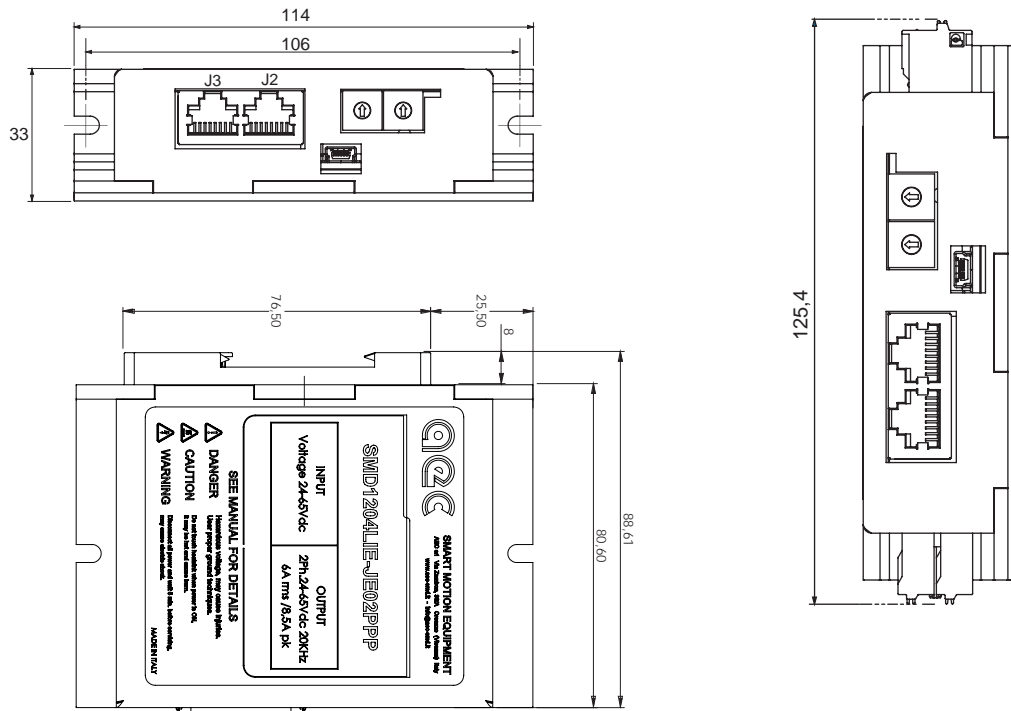

Dimensions are expressed in mm.

Characteristic	Specification
Weight	320 g
Cover material	Compliant with U.L. Spec 94 V-0 Flammability Rating

ABOUT INSTALLATION

Install vertically, securely fix the drive using M4x8 screws or the DIN rail mounting clip.

If installed inside an electric cabinet, leave a free space of at least 50 mm around the module in case of a single drive installation.

In case of installation of more than one drive, leave free spaces between contiguous drives, as it can be seen in the following picture, in order to ensure airflow and modules cooling.

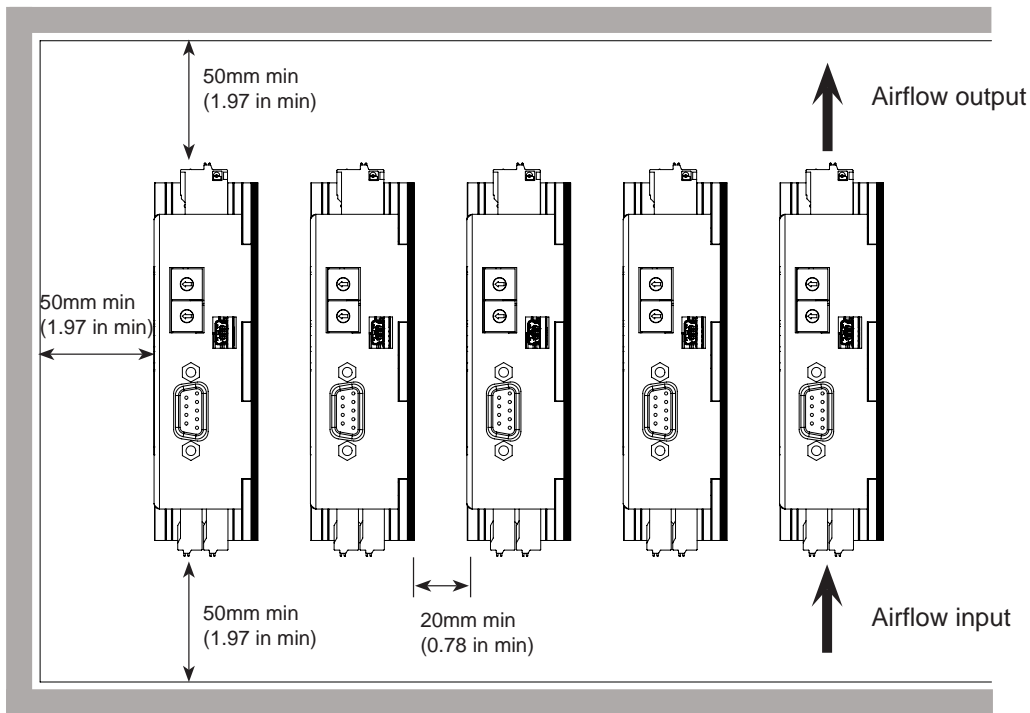
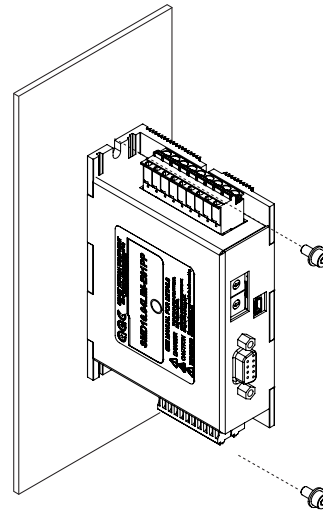

CAUTION

Do not cover ventilation slots and prevent foreign objects such as metal fragments or liquids from entering the product.

It is expressly forbidden to carry out modifications of any mechanical part of the drive.



Failure to follow this instruction may cause deterioration of internal components, fire and malfunctions

THERMAL DISSIPATION

Following you can find the trend of thermal dissipation, in relation to output current.

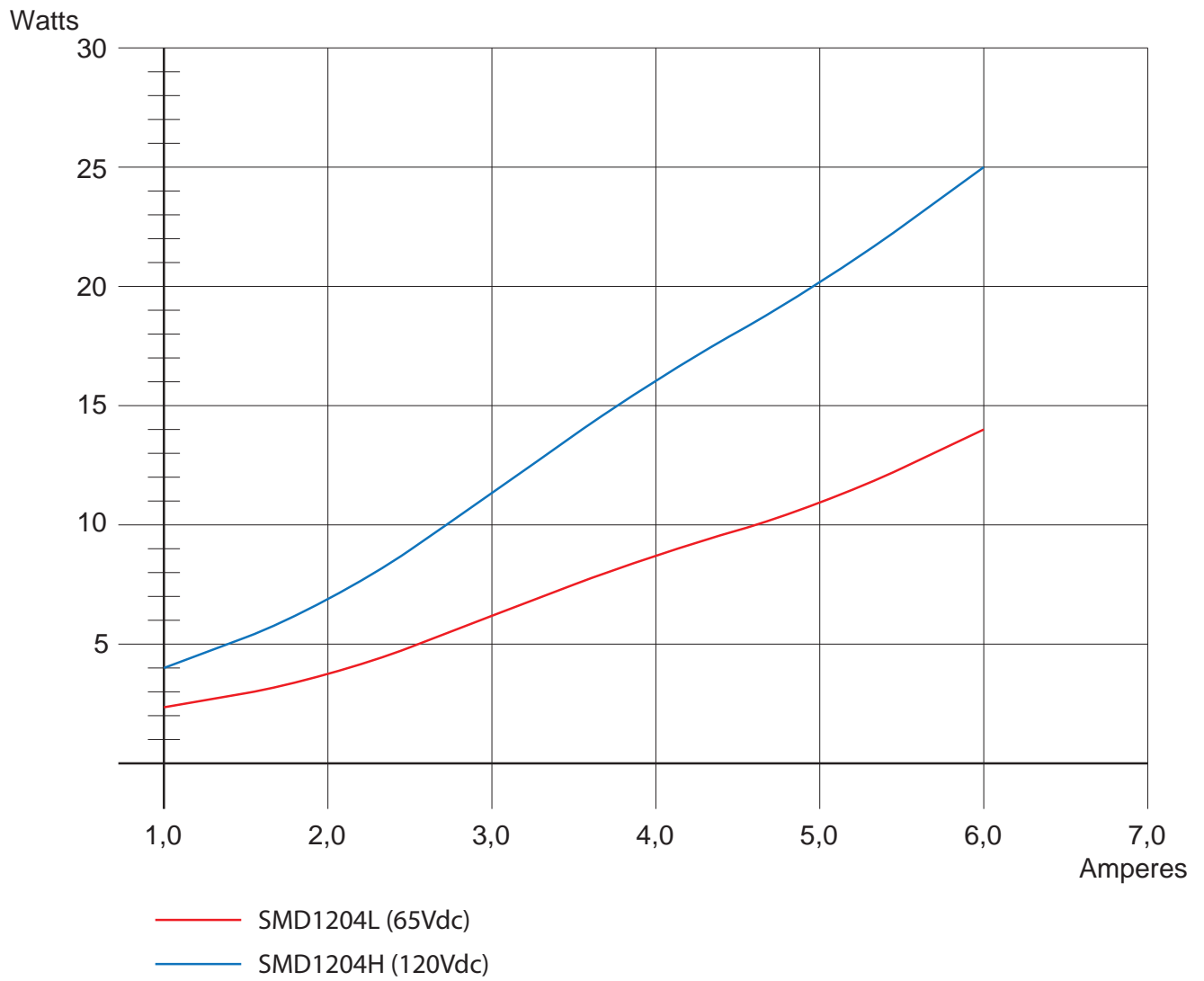

STEPPER-MODE FUNCTION

This function mode is very similar to the traditional method of control of stepper motors.

In fact, the drive works in open loop and generates the motion profile and the current levels, basing on internal registers (without direct feedback from the motor).

The drive behaves like a constant current generator and provides the configured nominal current, independently from the torque required by the movement.

The indexer updates the parameters of the movement in real-time, permitting to realize complex linked movements in speed (JOG) or in position (GO, absolutes and relative).

The VectorStep drives use the innovative control algorithm EVSC (Enhanced Vector Step Control), which permits to obtain a smoother and efficient handling of the stepper motor, as opposed to the traditional impulsive type control.

STEPLESS TECHNOLOGY

The stepless control allows to set any level of current within the operation range of the drive, and to decrease at minimum the commutation losses due to eddy currents, to reduce the overheating of the motor, to decrease mechanical vibrations caused by the jerky movement (steps) of the motor and, last but not least, to reduce drastically mechanical noise.

One of the prerogatives of stepper motors is the possibility to generate movements, even complex, without the aid of sensors (Hall, encoder, resolver, or other).

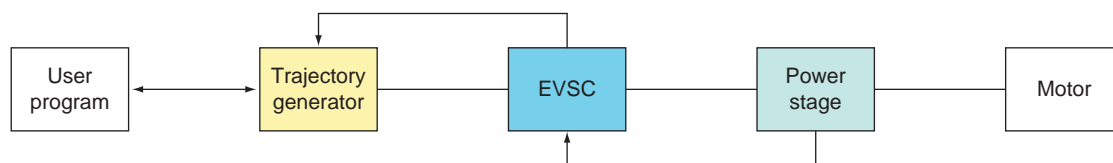

Diagram of the open loop chain of control

FRACTIONATION OF THE STEP

The fractionation of the step in stepper motors is always has been one of the main nodes to obtain good performances, both in terms of speed and in terms of noise and precision.

With the traditional systems of control (with setting of the hardware resolution), the user was forced to choose a single “compromise” resolution that met up all of the needs.

A high resolution, in fact, guaranteed a smooth and silent movement, but forced the user to utilize axis controllers with very high output frequencies: a low resolution, on the other hand, allowed to obtain high dynamics of movement, but with less precision and a higher noise.

The EVSC, thanks to the stepless technology, introduces an innovative concept in the use of stepper motors.

The VectorStep series is composed of microstep drives that work with a high-resolution of 1/1024th step (204800 steps per revolution). However, while maintaining the same physical resolution, it is possible to modify the working resolution through software, up to a 1/1 ratio.

Even in case of full step function, the movement of the rotor will be performed by interpolating the position between the two steps, in order to obtain the same behaviour as if maximum resolution was set.

This type of technology offers multiple advantages. It permits to:

quickly change the resolution of the motor, without causing undesired movements of the motor

keep constant the positioning precision with different resolutions set through software

perform movements with different resolutions (e.g. full step approach; then working at 1/1024th)

reduce mechanical resonances

being able to use the motor at the maximum resolution even with axis controllers with limited output frequency.

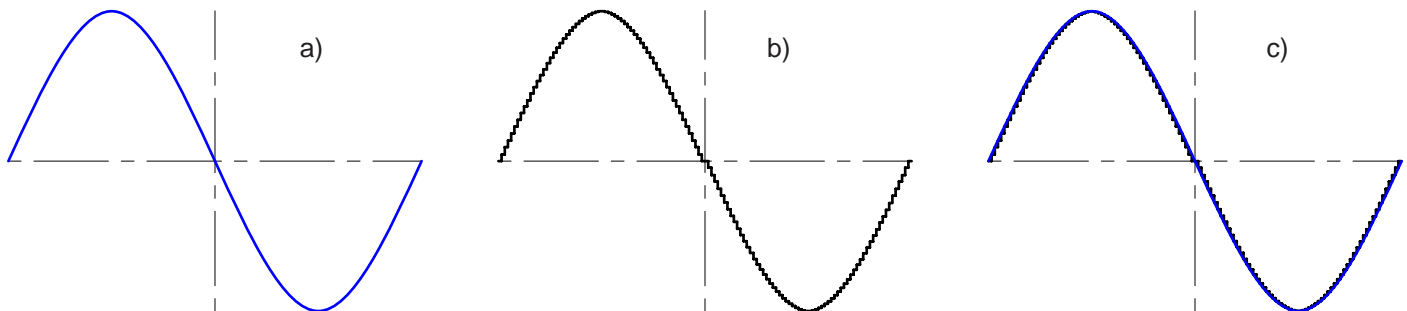

Profile of current to the motor : a) VectorStep with stepless technology b) Traditional microstep drive c) Comparison of profiles

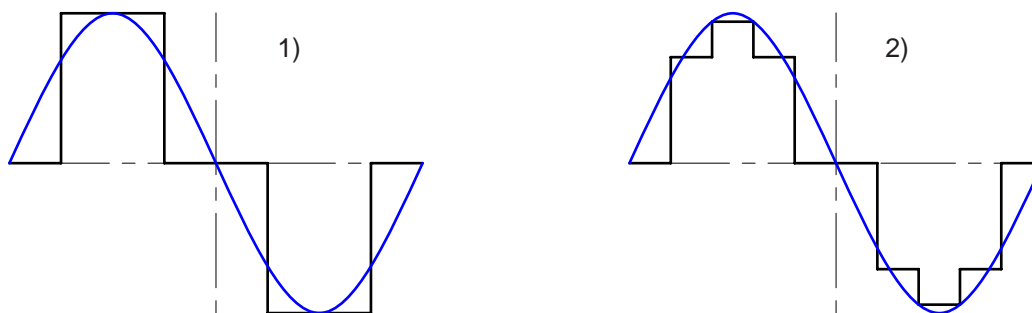

Difference between the profile of current of a traditional drive and a VectoStep drive at full step (1) and at half step (2)

CURRENT CONTROL

The drive in open loop, manages three pre-set levels of current: reduced current ($R_{curredd}$), nominal current (R_{curnom}) and boost ($R_{curboost}$).

The boost current, usually greater than nominal current, can be applied during acceleration and deceleration ramps. The time of the boost can be set in milliseconds and indicates the maximum time of the boost; in case that the time of the ramp is greater than the time of the boost, the current will be re-set at nominal value, even if the ramp is not ended.

During the normal function of the motor, like during constant speed rotation, the drive delivers the nominal current. The value of the current for each level can be set in mA.

The drive uses an I2T algorithm to protect the motor from overheating, by monitoring real-time the power supplied to the motor and the work cycles, in order to keep the temperature of the motor itself inside the allowable range.

CURRENT CONTROL ADVANCED FUNCTIONS

The Field oriented control (FOC), implemented in AEC drives, uses advanced algorithms for current control that permit to adapt the drive to any load typology or required performance.

The EVSC (Enhanced Vector Step Control) allows to: modify the PID of the current loop, in order to adapt the system to every type of motor; modify the phase angle of the current, thus to reduce resonances; deflux the motor, in case of high speed applications; modify the harmonic spectrum, so that the rotation of the motor is smooth and quiet, with reduced vibrations.

SMART-MODE FUNCTION

Smart-mode function includes two different types of operation:

1. velocity control function
2. position control function

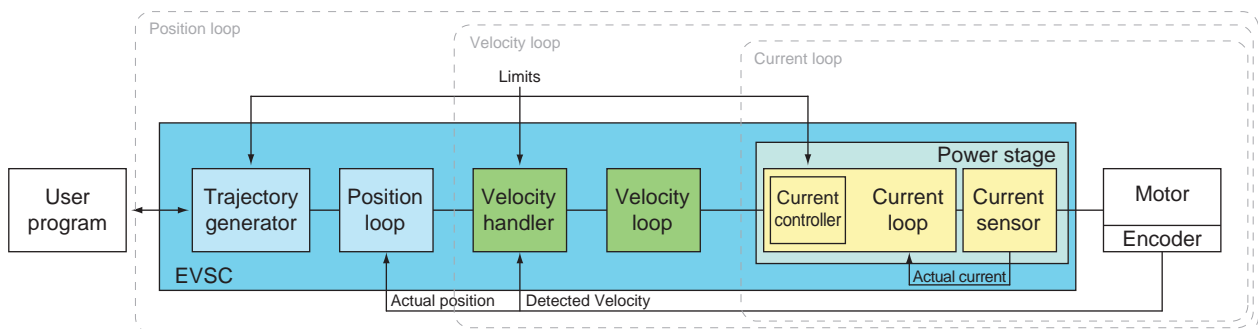

This mode is an hybrid between the Stepper-mode and the Servo-mode.

The drive works by using the encoder of the stepper motor to obtain a the position feedback, but at the same time it operates like a constant current generator, supplying the configured nominal current independently by the torque required by the movement.

This permits to manage the torque at the motor shaft, but with a current which is constant both during the movement and during the standstill moments, eliminating the oscillations due to the current regulation.

Gli azionamenti VectorStep in modalità Smart-Mode utilizzando l'innovativo algoritmo di controllo EVSC (Enhanced Vector Step Control) permettono di lavorare in controllo di coppia, in controllo di velocità anche con riferimenti di velocità esterni (ingresso analogico o tramite fieldbus) oppure di ottenere un posizionatore con tempi di risposta e dinamiche particolarmente performanti.

Regarding the fractionation of the step and the current control, the Smart mode works like the Stepper mode.

SERVO-MODE FUNCTION

Servo-mode function includes three different types of operation:

current control function (torque)

velocity control function

position control function

These modes of operation are defined nested, because position control interacts with velocity control, that in turn interacts with current control.

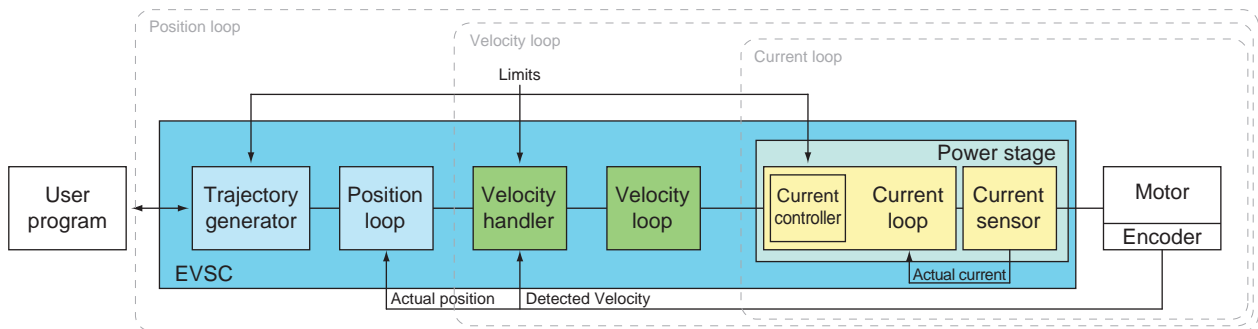

Servo-mode function is realized by using a stepper motor with an encoder feedback, in order to obtain a position feedback. The encoder doesn't only control the motor position, but, thanks to the EVSC, becomes an electronic collector which permits the drive to react real-time to load variations.

The closed loop control allows to optimize current and torque management of the motor, reducing thermal dissipation and exploiting 100% of the deliverable torque of the motor.

Servo-mode function permits to operate in torque control, velocity control (also with external references like analog input or fieldbus), or to get a positioner with very performant dynamics and response times.

RESOLUTION OF THE MOTOR

In Servo-Mode, the resolution of the motor is not given by the configured microsteps, but by the encoder resolution. The AEC integrated encoders has a fixed resolution of 512 ppr. Read in quadrature, it is possible to obtain a fixed resolution of 2048 steps/rev.

CURRENT LOOP

The VectorStep drives use the most advanced technologies in stator current control, which permit to optimize the effect of torque currents and to reduce the effect of dissipation currents (direct current).

Thanks to the EVSC, the thermal dissipation effects are reduced, and the control of resonances and form factor of output current are particularly accurate.

The current loop accepts in input the requested current, conditions its value (applies the limits) and generates a request of torque current and direct current. The actual current, given by current feedback, is deducted from demanded current, obtaining a current error that will be then processed to get a proportional contribution (proportional gain K_p) and a integral contribution (integral gain K_i). The resulting data are transformed in commands to be sent to the PWM controller, and then applied to the motor.

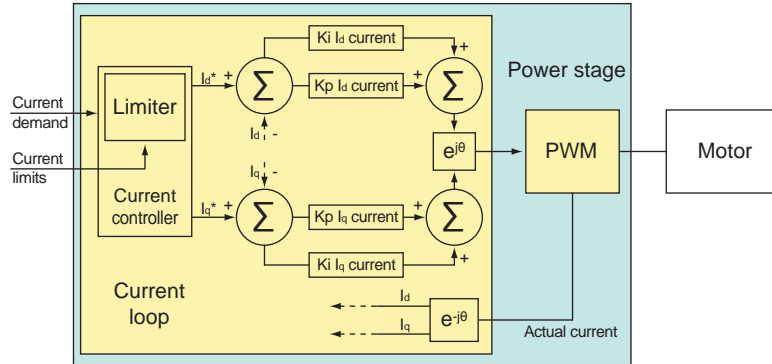

Requested current

In current control mode (or Torque) the requested current is set by the user.

When working with velocity or position control mode, instead, the requested current is generated from the velocity loop.

Current limits

The current limiter utilizes the following parameters:

Parameter	Name	Description
Rcurboost	Boost current	Maximum current peak that the drive can generate for a brief time of time. (This value must NEVER exceed the maximum current of the drive)
Rcurnom	Current limit	Maximum current that can be generated in continuous mode.
Rcurmax	Maximum current	Maxim current supplied by the drive. If this value is exceeded, an overcurrent fault will be generated.
RmaxI2T	Maximum I ² T	I ² T maximum value. If this value is exceeded, an I ² T fault will be generated.

Current loop gains

The current loop uses 4 gain parameters:

Parameter	Name	Description
Rkpiq	Torque current proportional gain (K_p)	The torque current error, obtained from the sum (Requested current - Actual current) is multiplied by this value. Increasing the K_p , the bandwidth increases, so the response time to the step is reduced. Too high values may cause system instability.
Rkiiq	Torque current integral gain (K_i)	The integral of the current error is multiplied by this value. The contribution of the integral action permits to bring the actual current exactly at the level of requested current. The integral error is the sum accumulated over the time by the actual error value.
Rkpid	Direct current proportional gain (K_p)	The direct current error, given by the sum (Requested current - Actual current) is multiplied by this value. Increasing the K_p , the bandwidth increases, so the response time to the step is reduced. Too high values may cause system instability.
Rkiid	Direct current integral gain (K_i)	The integral of the current error is multiplied by this value. The contribution of the integral action permits to bring the actual current exactly at the level of demanded current. The integral error is the sum accumulated over the time by the actual error value.

VELOCITY LOOP

The velocity loop is the conjunction element between the position loop and the current loop.

The data processed by the velocity loop produce a request of current that, sent to the current loop, generates the motor rotation.

The velocity loop accepts in input a requested velocity, conditions its value (applies the limits), and generates a request of current that is then sent to the current loop.

The actual velocity (detected by the encoder) is deducted from the demanded velocity, obtaining a velocity error that will be then processed to get a proportional contribution (proportional gain K_p) and an integral contribution (integral gain K_i).

The integral action is controlled by an anti-wind-up loop (filling dynamic gain K_{ci}), that keeps under control the integral error in case of saturation of the same.

The resulting data are transformed into a current request, to be sent to the current loop.

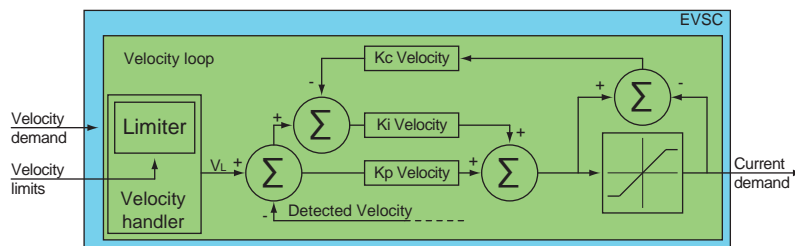

Requested velocity

In velocity control mode, the requested current is generated by the velocity loop.

When working in position control mode, instead, the requested velocity is generated from the position loop.

Velocity limits

Velocity limiter utilizes the following parameters:

Parameter	Name	Description
Rvelmax	Closed loop maximum velocity	Sets the maximum value that the requested velocity can take when working in closed loop.
Rdeceme	Emergency deceleration	Sets the deceleration ramp to be used in case of emergency stops, due to Abort or Fault.

Velocity loop gains

The velocity loop utilizes 3 gain parameters:

Parameter	Name	Description
Rkpvel	Velocity proportional gain (K_p)	The velocity error, obtained from the sum (Requested velocity - Actual velocity) is multiplied by this value. Increasing the K_p , the bandwidth increases, so the response time to the step is reduced. Too high values may cause system instability.
Rkivel	Velocity integral gain (K_i)	The integral of the velocity error is multiplied by this value. The contribution of the integral action permits to bring the actual velocity exactly at the level of demanded velocity. The integral error is the sum accumulated over the time by the actual error value.
Rkcvcl	Velocity conditional integral gain (K_c)	The error due to the saturation (wind-up) of the velocity loop is multiplied by this value, and deducted from the velocity error integral. Increasing the K_c , the bandwidth increases, so the response time to the step is reduced, even in case of sudden variations of the input signal (Requested velocity). Too high values may cause system instability.

POSITION LOOP

The position loop can receive the target from the internal program, from the inputs, or from the fieldbus.

When the trajectory generator receives a new target, it updates real-time the motion profile, transferring to the position loop the instant requested position, that, deducted from the actual position detected by the encoder, generates a position error.

The resulted error is then processed to get a proportional contribution (proportional gain K_p) and an integral contribution (integral gain K_i). The integral action is controlled by an anti-wind-up loop (filling dynamic gain K_{ci}), that keeps under control the integral error in case of saturation of the same.

The resulted data are transformed into a velocity request, to be sent to the velocity loop.

In order to make position control the most stable and efficient possible, some predictive-type loops have been implemented, like feed forward e acceleration forward, that work for compensate the dynamical friction and the inertia of the load.

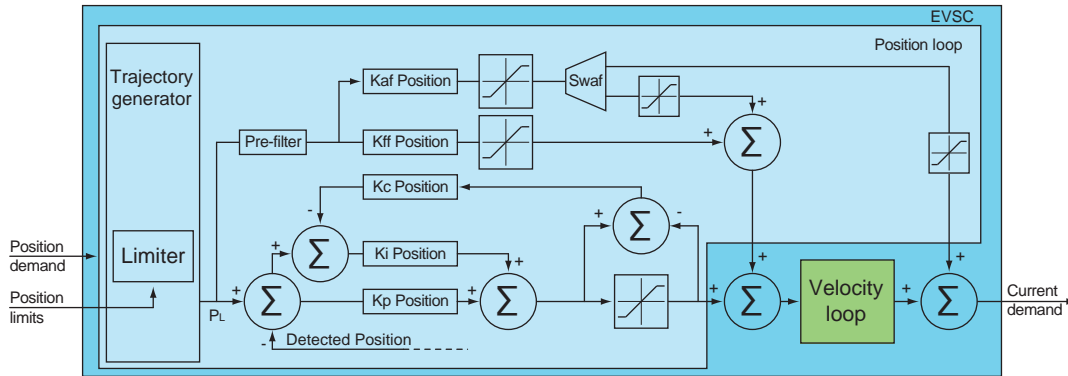

Requested position

The requested position can be set from the internal program, from the fieldbus or manually from the user.

Trajectory limits

Trajectory limiter uses the following parameters:

Parameter	Name	Description
Ruplim	Maximum limit quota	Sets the maximum value that the quota requested by the trajectory generator may take.
Rlowlim	Minimum limit quota	Sets the minimum value that the quota requested by the trajectory generator may take.
Rvelmax	Closed loop maximum velocity	Sets the maximum value that the demanded velocity can take when working in closed loop.
Rdeceme	Emergency deceleration	Sets the deceleration ramp to be used in case of emergency stops, due to Abort or Fault.

Velocity loop gains

Position loop uses 5 gain parameters and 1 selection parameter:

Parameter	Name	Description
Rkppos	Position proportional gain (K_p)	The position error, obtained from the sum (Requested position - Actual position) is multiplied by this value. Increasing the K_p , the bandwidth increases, so the following error is reduced. Too high values may cause system instability.
Rkipos	Position integral gain (K_i)	The integral of the position error is multiplied by this value. The contribution of the integral action permits to bring the actual position exactly to the demanded position. The integral error is the sum accumulated over the time by the actual error value.
Rkcpos	Position conditional integral gain (K_c)	The error due to the saturation (wind-up) of the position loop is multiplied by this value, and deducted from the position error integral. Increasing the K_c , the bandwidth increases, so the following error is reduced, even in case of sudden variations of the input signal (Requested position). Too high values may cause system instability.

Rkffpos	Feed-Forward position gain (Kff)	<p>The Feed-forward loop operates in a predictive way, by requesting the velocity loop to give a proportional contribution (Kff) to the demanded velocity. The Feed-forward loop compensates the dynamic frictions, resulting in reduction of position error. A correct adjustment of the Kff gain permits to reduce, or eliminate, the integral contribution, obtaining a most rapid response during the transients.</p> <p>This contribution must be regulated by observing the following errors at constant velocity. It can be observed that increasing this contribution, the integral part can be decreased.</p>
Rkafpos	Acceleration Forward position gain (Kaf)	<p>The Acceleration-Forward loop operates in a predictive way, by requesting the velocity loop or the current loop to give a proportional contribution (Kaf) to the demanded acceleration. The Feed-forward loop compensates the inertia of the load during velocity variations. By supplying in advance a current request (recommended), the following errors decrease.</p> <p>This contribution is to be used very carefully, by observing the following errors in acceleration phases, and must not be used in applications with variable inertia.</p> <p>Too high Acceleration-Forward values may cause system instability.</p>
Rswacfw	Action selection Switch Acceleration-Forward	Allows to choose if the Acceleration-Forward must generate a current contribution (recommended) or a velocity contribution.

1 $T = J * \alpha$ (α = angular acceleration, T = torque, J = inertia)

The output of the Acceleration-Forward loop is:

$OutAfw(t) = Kafw * \alpha_R(t)$ (where $\alpha_R(t)$ is the requested acceleration)

ADVANCED FUNCTIONS

PHASE ADVANCE

The Phase Advance control permits to progressively modify the drive angle of the vector, so that to reduce the counter-electromotive force (f_{cem}) and to modify the effect of the torque current.

The applicable shift is inversely proportional to the load and the inertia of the same: greater is the load, lower must be the applied shift.

Too high values of the Phase Advance may cause the instability of the current loop.

The Phase Advance control uses the following parameter:

Parameter	Name	Description
Rphgain	Phase Advance gain	FOCONTROL Phase Advance gain

POWER SUPPLY STAGE

The choice of the power supply stage is the first step to obtain the best performances from an automation system.

Each drive is a particularly heavy load for a power supply, because it generates voltage peaks or important energy requests in short times, during acceleration or deceleration phases.

It is therefore important to size correctly the power and the output capacity of the power supply.

The SMD1204Lxx drives need a power supply voltage between 24 and 85Vdc insulated with respect to the main network (for the power stage), and a 24Vdc voltage (for the logic stage).

The SMD1204Hxx drives need a power supply voltage between 24 and 130Vdc insulated with respect to the main network (for the power stage), and a 24Vdc voltage (for the logic stage).

It is required to supply the power stage and the logic stage separately, in order to permit to maintain active the indexer also in absence of supply to the power stage.

LOGIC STAGE POWER SUPPLY

DC power supply

		Min.	Typ.	Max.	Units
Voltage	Nominal value, $\pm 10\%$ ripple included	22	24	26	Vdc
	Absolute maximum values in continuous operation §	22	24	26	Vdc
Current	Nominal value	150		1500	mA
Protection	External fuses	3A			

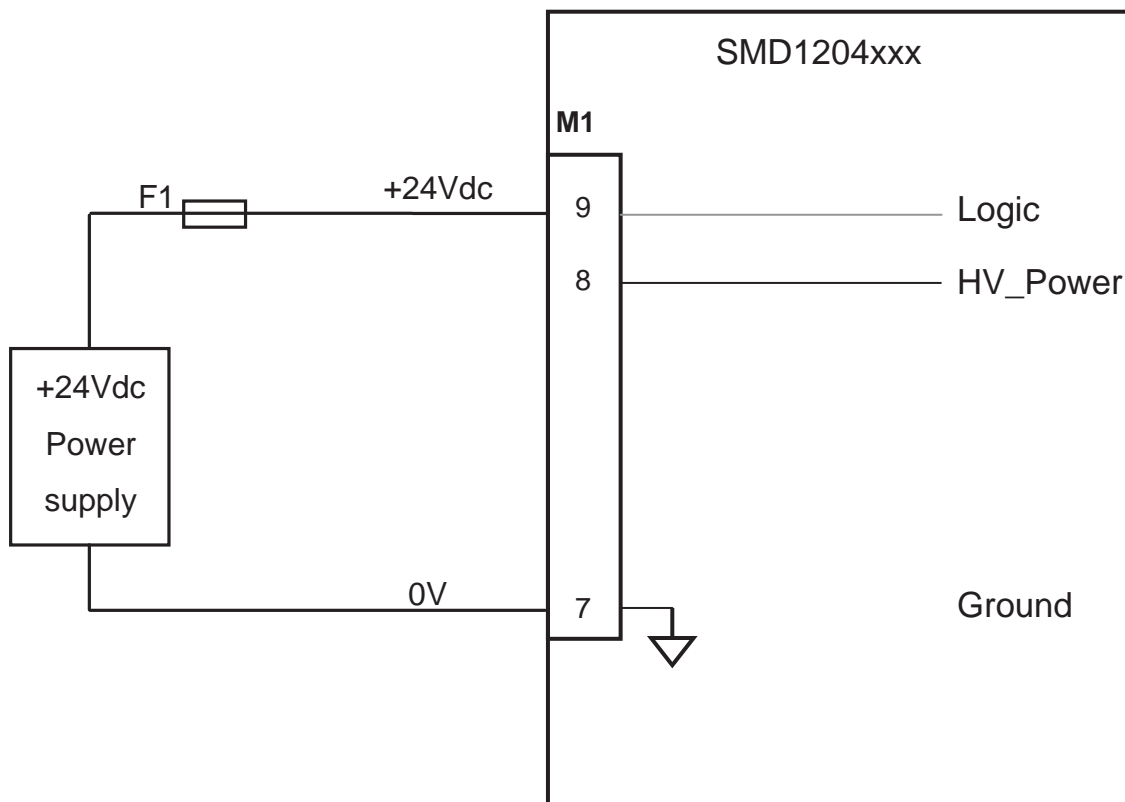

POWER STAGE POWER SUPPLY

DC power supply

DC power supply			Min.	Typ.	Max.	Units
Voltage	Nominal value, $\pm 10\%$ ripple included	SMD1204L	24	65	85	Vdc
		SMD1204H	24	120	135	
	Absolute maximum values in continuous operation §	SMD1204L	24	65	85	Vdc
		SMD1204H	24	120	135	
Current	Peak value		0		6	A
	RMS sinusoidal value		0		4.2	A
Protection	External fuses		10A ritardato			

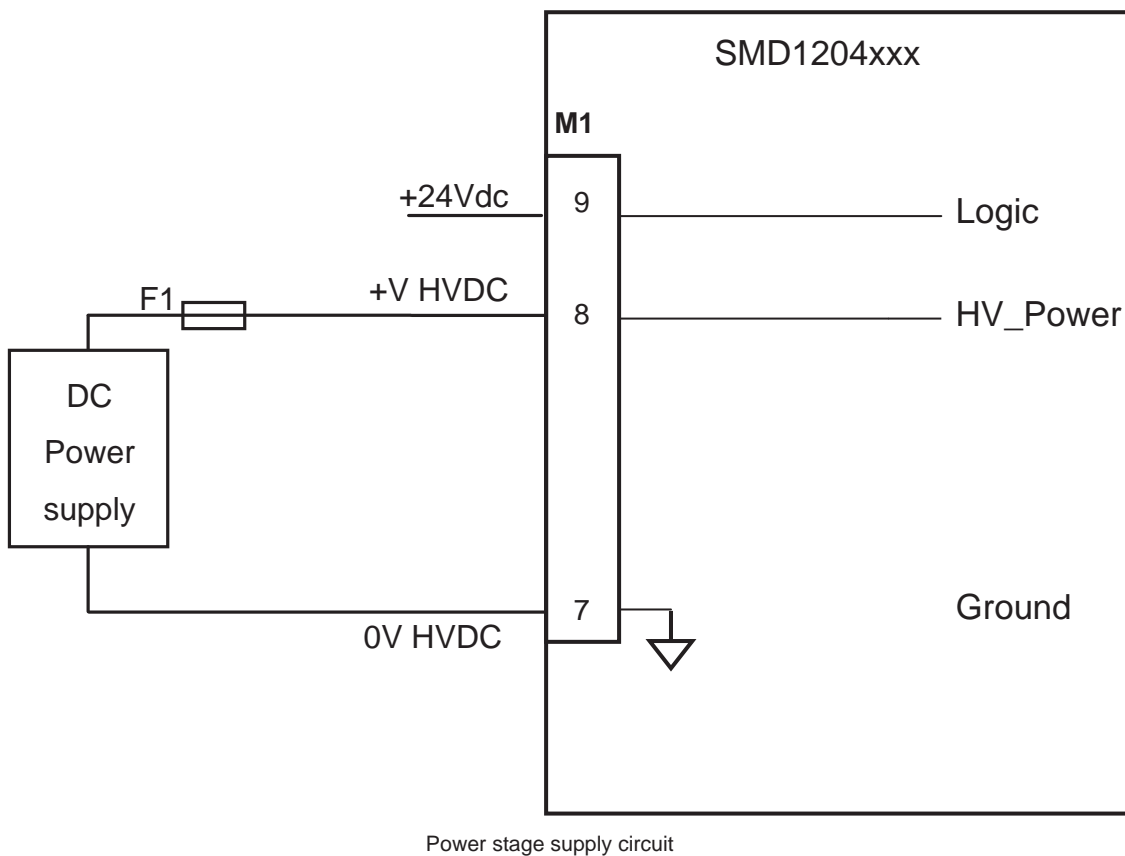

The configuration of the input circuit independently supplies the control stage with respect to the power stage. This solution allows to keep active the indexer (axis controller) in an absolutely safe condition.

Note: it is not possible to move the motor in any way, if HV Power voltage is not supplied.

Use a proper cross section cable and a correctly sized contactor to supply the HV_Power voltage to the drive.

TYPES OF POWER SUPPLIES

A power supply is a device able to deliver the proper voltages (and so the currents) to an electronic circuit, in order to permit its proper operation.

In general, the task of a power supply is to transform a certain type of voltage in another, having the proper characteristics for the device that has to be feeded.

There are many types of solutions to manufacture a power supply:

- Unregulated power supplies
- Regulated power supplies

In the first case, which is the simpler, the device is composed of a transformer, a rectifier bridge and a filter capacitor.

It is a simple and cheap system, but it has the disadvantage of having an output voltage that may vary depending on the input voltage and on the load.

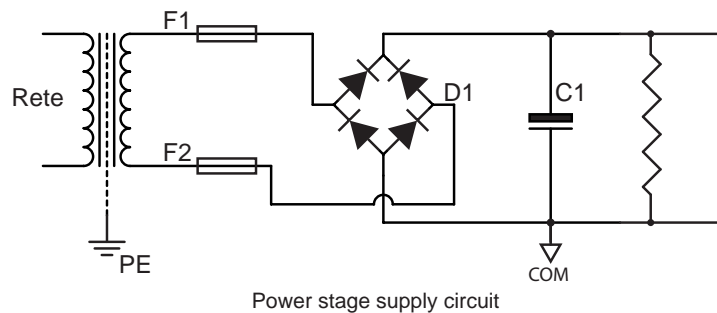

In the second case the output voltage of the device is regulated and maintained constant, also if load varies, thanks to a switching or linear controller.

The switching technology permits to obtain very efficient and compact power supplies, but it is more complicated and expensive to be made.

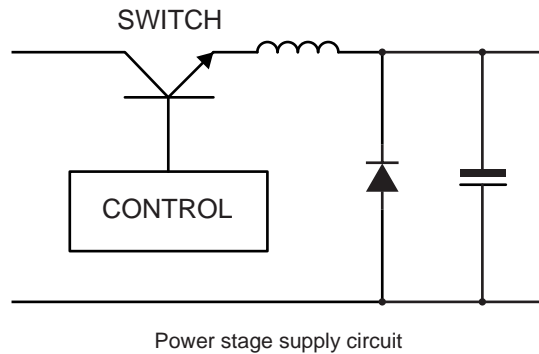

In case of use of regulated power supplies, it is necessary to put a diode with the cathode facing outward, in series with the output of the power supply, in order not to let the supply going into protection.

NOTES ON UNREGULATED POWER SUPPLIES

Following you can find the typical configuration of an unregulated power supply.

It is one of the most adopted solutions for its simpleness and cheapness, but it is important to follow some guidelines in order to obtain a reliable and efficient feeder.

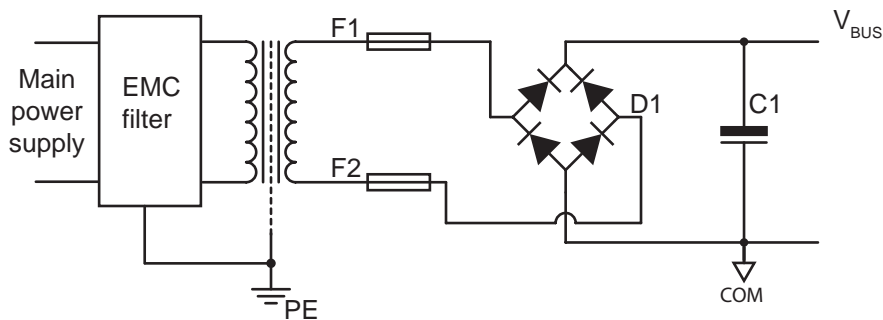

In order to reduce the influence of EMI disturbances, it is recommended the use of our AC/DC converters with integrated filters AL1120 or AL2620, or as an alternative, of a specific network filter (like CORCOM 10AYO1 in case of three-phase supply, or CORCOM 10VT1 in case of single-phase supply).

Use transformers with shield between primary and secondaries, and connect it to earth (PE).



NEVER connect the secondary of the transformer to earth; this type of connection causes a short-circuit on the diodes of the bridge rectifier D1.

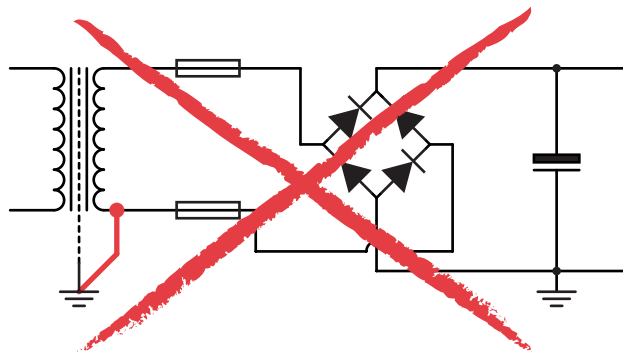

One of the most important component of a power supply is the output capacitor of the same.

C1 must be able to absorb the energy generated by the drive during brakings, and must supply energy during accelerations (current request), monitoring the voltage fluctuations on the bus.



In case of a single axis, the energy can be considered proportional to the current and to the supply voltage , therefore capacity must be choose in order to absorb the energy generated from the nominal current of the motor and the voltage of the bus.

With the decreasing of the supply voltage , it will be necessary to increase the value of the capacitor, considering that the capacitance of a capacitor to absorb energy decreases with the square of the voltage.

Choice of the transformer

Make sure that the electric characteristics of the transformer guarantee its correct functioning in case it works with the maximum possible voltage and the minimum admitted line frequency

The peak voltage of the bus (excluding spikes generated by commutations of current or regenerative effects) is, with good approximation, equal to:

$$\text{Single-phase connection} \quad V_{\text{bus}} = \sqrt{2} \times V_{\text{secRMS}} - 1,5 \text{ V}$$

$$\text{Delta/wye three-phase connection} \quad V_{\text{bus}} = \sqrt{3} \times V_{\text{secRMS}} - 1,5 \text{ V}$$

$$\text{Wye/delta three-phase connection} \quad V_{\text{bus}} = 1/\sqrt{3} \times V_{\text{secRMS}} - 1,5 \text{ V}$$

Example:

In case that RMS voltage at secondary is equal to $48V_{AC}$, the voltage of the bus will be equal to:

- $1.4142 \times 48 - 1,5 = 66 V_{DC}$ in case of single-phase connection
- $1.7320 \times 48 - 1,5 = 82 V_{DC}$ in case of delta/wye three-phase connection
- $0.5773 \times 48 - 1,5 = 26 V_{DC}$ in case of wye/delta three-phase connection

Usually, the rating plate data of the transformer indicates the voltage at the secondary at a specific current (nominal current).

In case that the current absorbed by the load is lower than the nominal current, output voltage will increase inversally to the absorbed current.

The following chart summarizes the possible deflectings of the output voltage in relation to the the power of the transformer:

Power (VA)	Maximum deflecting of V_{SEC}
1 - 100	10%
100 - 350	8%
> 500	5% or less

When the system works close to the maximum values allowed by the drive, it is important to consider this effect, together with the fluctuations of the line voltage, in order to avoid that the voltage of the bus exceeds the maximum value allowed by the drive.



Apply voltages higher than those allowed may cause damages to the device, fire or injuries!

The power of the transformer depends on the current set in the drive, and on the number of drives connected together.

To optimize the sizing of the power supply stage, it is recommendable measuring the current absorbed by the device in the worst condition possible. In case of difficulties in measuring, assume that the required current is equal to the set nominal current.

In multi-axis configurations the maximum current peak depends on the number of drives simultaneously active; the stopped drives need a reduced power if in "current reduction" or "no current".

Choice of the fuse

It is recommended to use 8A delay-action fuses in case the drive is setted at 4 A.

In case of setting of lower currents, it is possible to choose fuses of equal characteristics, but with lower rated current.



The use of fuses as protection system is essential. Possible faults or short-circuits, in absence of such safety device, may cause explosions, fire, or damage to the equipment.

Notes on energy regeneration

During decelerations, the drive may generate a voltage that tends to increase the voltage level of V_{BUS} . In fact, in phase of decelerations, the motor becomes a generator which converts mechanical energy into electric energy.

If the mechanical energy of the system is lower than the losses of the system, then V_{BUS} will not be subject to alterations, else, it will increase proportionally to the mechanical energy of the system.

Mechanical energy is given by:

$$E_M = 1/2 \times J \times \omega^2$$

where:

E_M = Kinetic energy (joules)

J = Inertia ($Kgxm^2$)

ω^2 = Speed (rpm)

If all the kinetic energy were converted to electric energy, V_{BUS} would increase as following:

$$V_{BUS} = \sqrt{V_0 + \frac{2E_M}{C}}$$

where:

E_M = Kinetic energy (joules)

C = Total capacity (Farad)

V_0 = Initial voltage (Volt)

In most cases, kinetic energy is dissipated and dispersed from the drive, so the “pump” effect on the V_{BUS} voltage assumes negligible levels.

In some cases, when the system works with high speeds, with high inertia loads, the regenerative effect may assume important levels, and it may be necessary to adopt circuital solutions in order to contain the increase of the V_{BUS} voltage (CLAMP circuits).

To verify the influences of the regenerative effect to the bus voltage, it is possible to measure with an oscilloscope the V_{BUS} voltage during the brakings of the drive. (As an alternative, it can be used a peak detector, made with a diode and a capacitor, and measure the voltage at the ends of the capacitor with a multimeter.)

By slowly increasing the slope of the deceleration ramps, it is possible to measure the rise of the V_{BUS} voltage due to the “pump” effect.



The V_{BUS} voltage must never exceed the maximum allowable voltage of the drive.

SUPPLY CONFIGURATION

ⓘ Disconnecter

Always provide a disconnecter in order to protect devices.

ⓘ Safety switch

It is used to deactivate power supply of the drive in case of emergency.

ⓘ Fuses

Always provide fuses to protect devices.

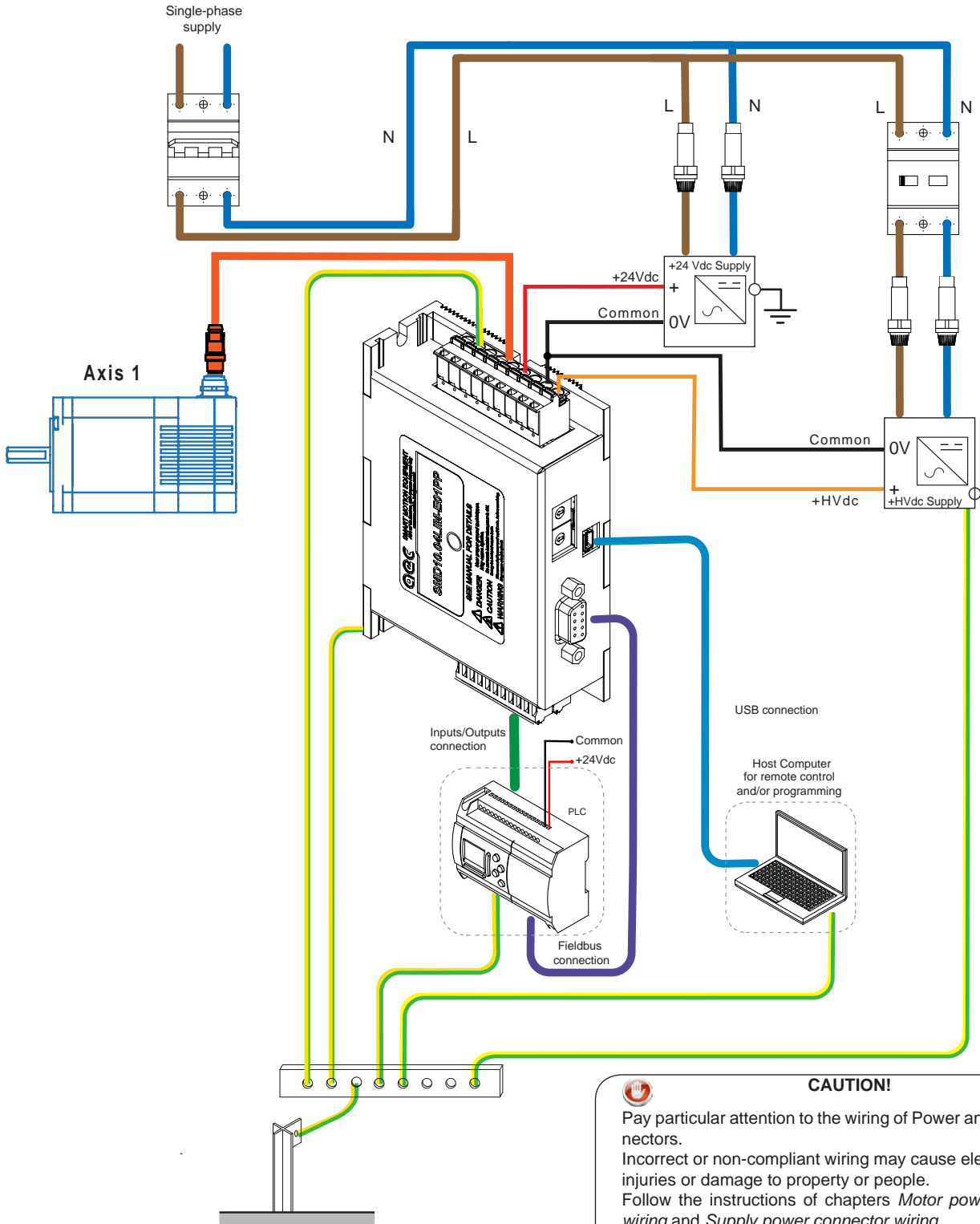

Devices surrounded by the dashed box are not required for system operation, but they extend the potential of the same.

TYPICAL WIRING

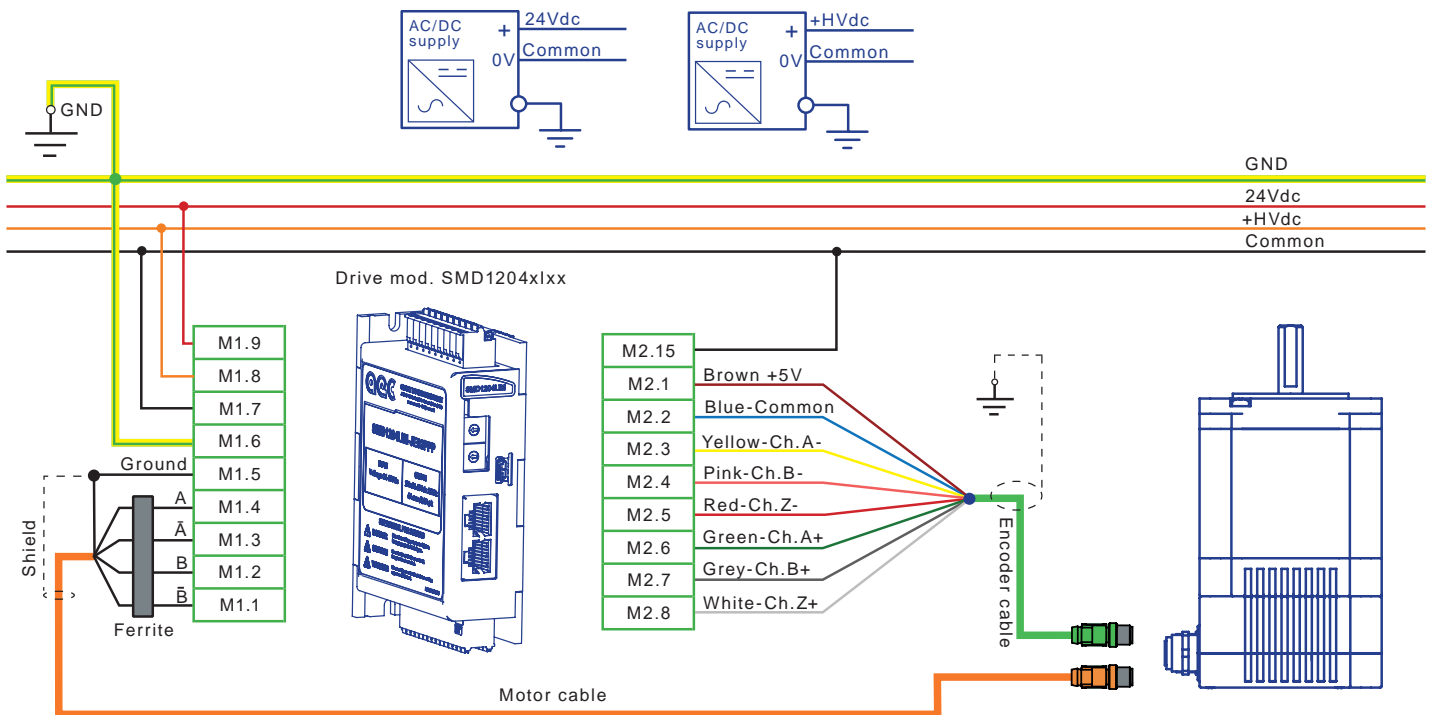

The components must be mounted close together on a common galvanized mounting plate and connected to it with a large conductive surface. This mounting plate, in turn, must have a conductive connection with a large contact surface with the motors or the machine. The painted walls of electric cabinets or mounting plates and rails or similar means of mounting with reduced surface of contact, do not meet these requirements. Use transformers with shield between the primary and secondary. Always connect the shield of the transformer to the ground bar.



CAUTION

- Make sure of proper grounding of the drive and the motor.
- The ground connection must provide a preferential path for the discharge to ground of the leakage currents.
- The shield of each cable must be connected to earth.
- The ground connections must merge into a single point to prevent the formation of ground loops.
- To configure a safe system, install a protective device against overload and short-circuits.
- The wiring must be carried out by authorized personnel, specialized in electrical works.
- Make sure you have carried out proper connection of power supply stage.
- Use shielded twisted pairs of proper section for power and motor connection.
- Use copper cables with temperature range of 75°C or more.
- Do not bend or apply mechanical tension to cables or connectors.
- All protection devices must be evaluated and sized correctly according to the application.
- Keep a distance of at least 300 mm between the power cables and signal cables.
- The residual voltage let the motor rotate for some seconds after that power is turned off, until the complete discharge of capacity.
- Make sure to fully stop the motor by interrupting the connection of power supply of the power stage (emergency stop)
- The information contained in the internal registers are not usually stored in the drive, therefore they will be lost in case power supply of the control stage is turned off. In case you want to save these information, activate the NVRAM saving procedure.
- In the case of use of a motor in vertical axes, install safety devices to prevent possible falls of parts in case of emergency or fault. The fall of parts may cause injuries.



CAUTION

- **Avoid short-circuits, incorrect connection of the mass conductors and polarity inversions.**
- **Before inserting the power connector, check the voltage levels.**
- **Always connect the ground terminal.**

PROTECION FOR THE POWER SUPPLY LINE

Use a disconnecter device and a fuse to protect the power supply line. The SMD1204xxx can be supplied by rectifying and filtering the secondary of a three-phase transformer (or single-phase); use transformers with shield between the primary and the secondaries, in order to guarantee a good immunity to line disturbances.

EARTH CONNECTION, MASS CONNECTION AND SHIELDING

The grounding connection must meet all local applicable requirements about industrial installations.

The grounding of the drive and the motor must be carried out in a workmanlike manner

For the grounding of one or more drives, use a copper earth bar, fixed to the galvanized bottom of the electric cabinet using insulated supports.

The ground connection must have a R_{EG} resistance equal to 100Ω , or preferably less.

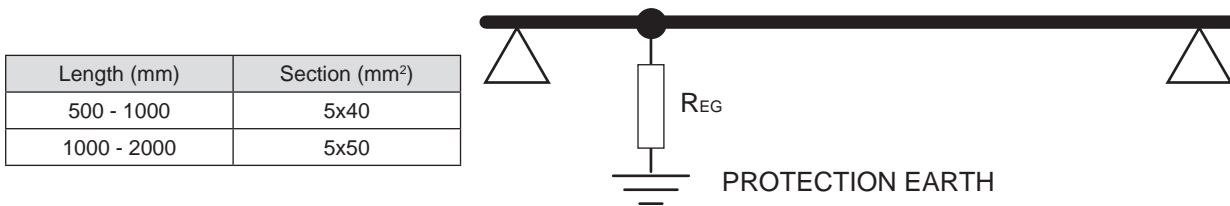

The following parts must be connected to the mass bar:

- The cover and /or the heatsink of each drive.
- The shield of each cable.
- The 0V of the DC supply voltages.
- The commons of the input/output stage, the analog references stage and the communication ports stage.
- The earth conductors of control or display units (PC, PLC, terminals, HMI, CNC).

Connect the bar to the ground point of the electric cabinet (stud copper), using a cable with section of at least 4 mm^2 .

Connect the front panel to the ground point with a copper braided cable.

Connect the earth point to the system earth.

Example of a grounding connection

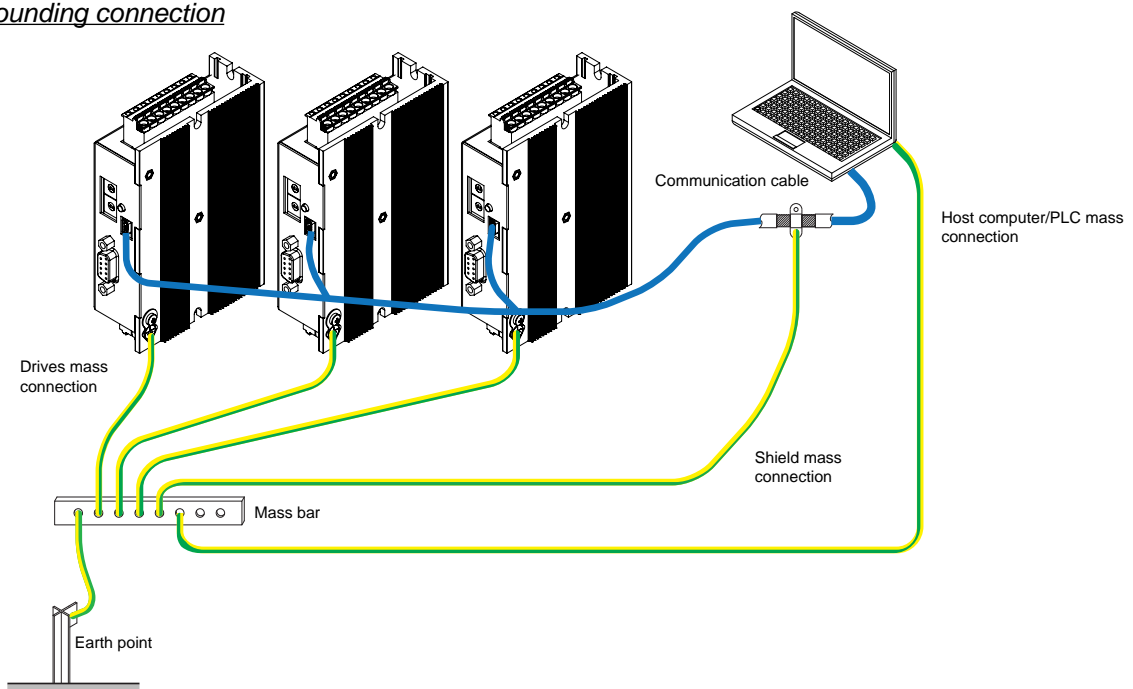

Example of connection of three drives

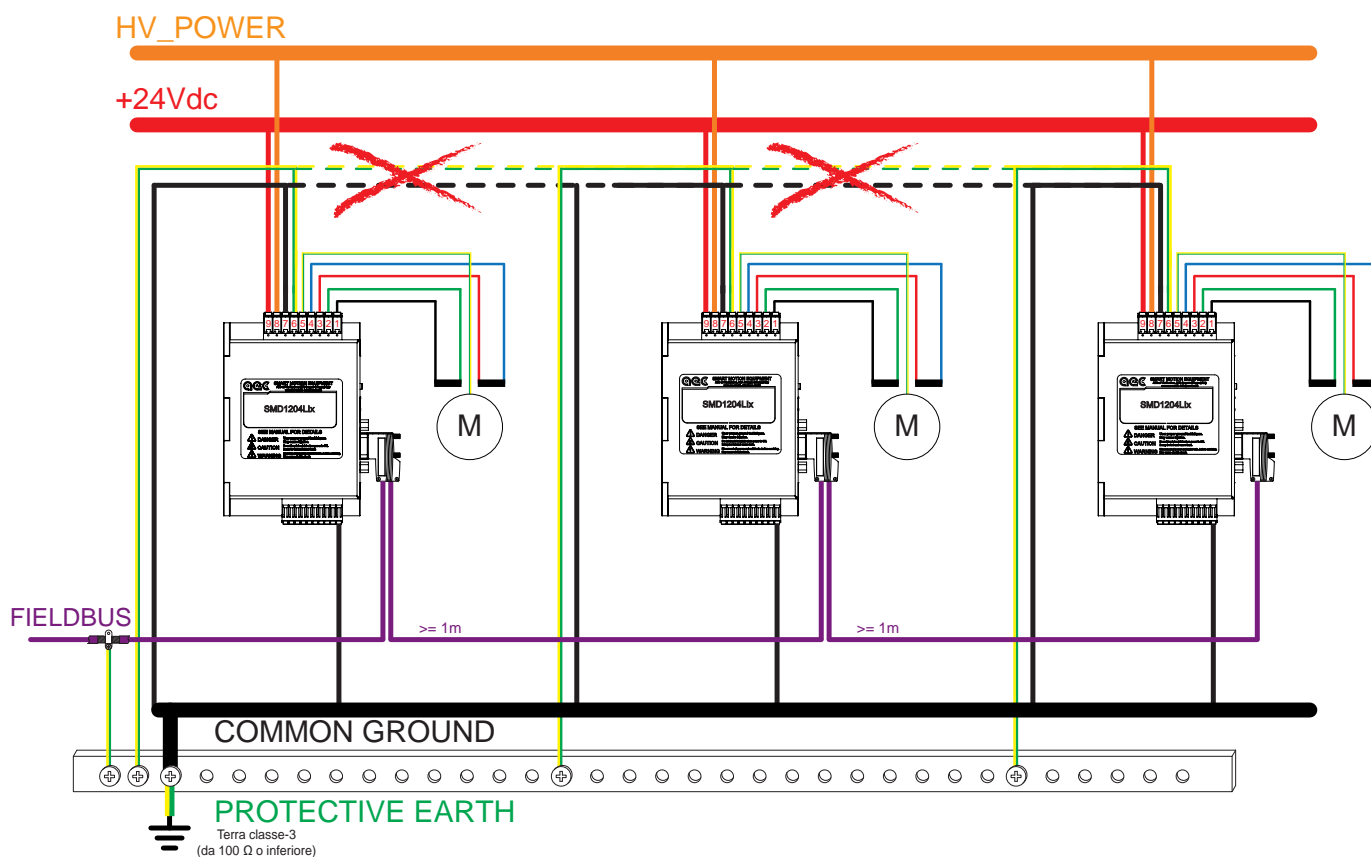

CAUTION !!! A wrong positioning, connection, shielding or grounding of the drives or devices connected to the drives, may cause electromagnetic disturbances. The presence of EMC disturbances in electric cabinets may cause malfunctioning of high speed inputs and communication lines.

SUGGERIMENTI PER LA PREVENZIONE DEI DISTURBI

The electromagnetic compatibility of the installation must be checked and guaranteed before starting the system. If the instructions below are followed, the drive system will meet the requirements of CE Directive on EMC environmental immunity in accordance with DIN EN 61800-3: 2001-02. To meet the limit values for EMC immunity and radiated interference for it is necessary to earth the drive.

- The use of twisted cables, even without shield, allows to reduce low-frequency interference. However, modern applications require fully-shielded installations in order to ensure a greater disturbance immunity.
- A good ground connection is essential to ensure signals high quality, whether they are inputs/outputs or communication lines.
- The following cables must be shielded:
 1. Communication cables (Fieldbus)
 2. Supply Voltage HV_POWER
 3. 24V interface signals
 4. Motor and encoder cables

- A proper connection ensures that the eddy currents are closed towards the earth of the system, rather than recirculate through signal cables.
- Keep cables as short as possible.
- Keep cables lying.
- During the connection pay particular attention not to create ground loops, which produce common mode currents that are the main source of disturbances in electrics and electronics systems.
- The ground connections must merge into a single point to prevent the formation of ground loops.
- In order to avoid disturbances, the shieldings must be connected on both sides. Potential differences can result in unacceptable currents on shieldings, which must be neutralized through potential equalisation conductor. If conductors are more than 100 m length, follow these instructions: up to a length of 200 m, a section of 16 mm² is enough; in case of length of more than 200 m, it is required a section of 20 mm².
- Do not connect inductive loads (such as electric motors, relays, electromagnetic brakes or switching devices) on the auxiliary supply line (+24Vdc);
- If lines are interrupted, make sure to connect them with connectors, paying attention that cables insulation is not uncovered for more than 50 mm length;
- Avoid inductive and capacitive couplings, which may result in disturbances. Do not twist cables. If cables are too long and are twisted, inductance and mutual induction will increase, causing malfunctioning.

TYPES OF CABLES

Length and section of power cables are very important aspects to obtain a safe and performant system.

The section of the cable varies as a function of current and length. In the following table you can find the recommended sections.

Recommended sections for power and motor cables						
1 A_{PK}						
Length (m)	3	7,5	15	22,5	30	
Minimum section (mm ²)	0,75	0,75	1	1	1,25	
2 A_{PK}						
Length (m)	3	7,5	15	22,5	30	
Minimum section (mm ²)	0,75	1	1,25	1,5	1,5	
3 A_{PK}						
Length (m)	3	7,5	15	22,5	30	
Minimum section (mm ²)	1	1,25	1,5	2	2	
4 A_{PK}						
Length (m)	3	7,5	15	22,5	30	
Minimum section (mm ²)	1	1,25	1,5	2	2	
5 A_{PK}						
Length (m)	3	7,5	15	22,5	30	
Minimum section (mm ²)	1,25	1,5	2	2	2	
6 A_{PK}						
Length (m)	3	7,5	15	22,5	30	
Minimum section (mm ²)	1,25	1,5	2	2	2	

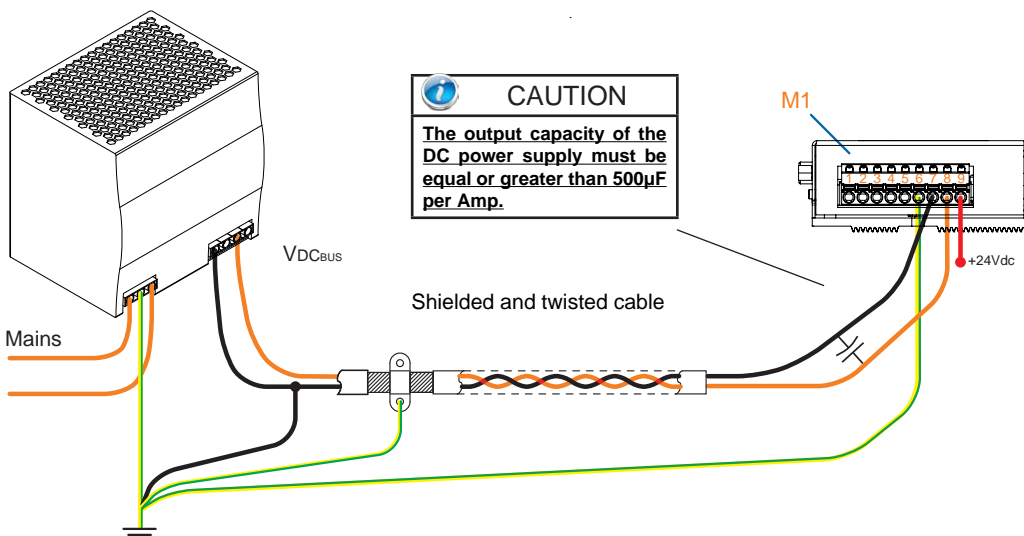

DC connection with cables of length lower than 15m

For high distances between the power supply stage and the drives, it is recommended to use alternating voltages and to install AC/DC conversion systems close to the drive. Also in this case it is recommended the use of shielded and twisted cables.

CE COMPLIANT INSTALLATION

In order to obtain an installation compliant with the EMC directives (EN61800-5-1), it is necessary to meet the following conditions:

- the drive must be installed inside a metal box (electric cabinet);
- use shielded cables for I/O lines and communication lines;
- use shielded cables for motor connection;
- all the cables coming out from the electric cabinet must be wired in metal conduits;
- the shield of the cables must be directly connected to the earth bar.
- install on the unsheathed part of the cables FAIR-RITE ferrites mod. 0431167281 or similar (optional, in order to bring the EMC emissivity level to Class C2)

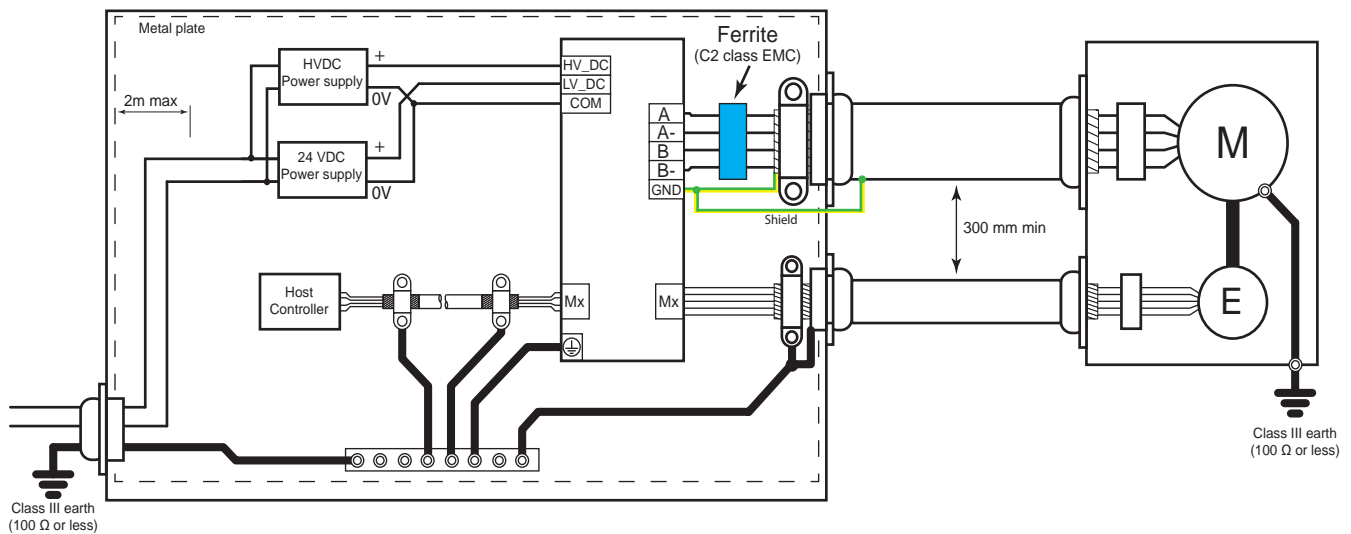

CAUTION!!! Wrap the cables for a turn and a half around the ferrite! Shield wire and Earth wire must not be passed through the ferrite, but externally.



CAUTION!!! In order to comply with the directives mentioned above, the drives must be installed in accordance with the instructions described in the user manual of the product.

Since the drives are installed into a system, they need a new confirmation of compliance after the installation.

Since the drives are components to be incorporated into a machinery, it is necessary to verify that the complete machinery comply with the requirements of the current machinery directive before putting it in service.



The use of the ferrite is useful to bring the emissivity levels within the EMC C2 Class. In case it is not used, the device is classified as C3.



CAUTION

During M1 connector wiring (power connector), take the following precautions.

1. Remove the terminal block from the drive.
2. Insert only one conductor for each contact on the connector.
3. Make sure that there aren't exposed parts of the conductor which may create short-circuits.

Power and motor connector

Description	Removable spring-cage terminal block, 9 positions
Dimensions of conductor	12 - 24 AWG

Terminal block pinout

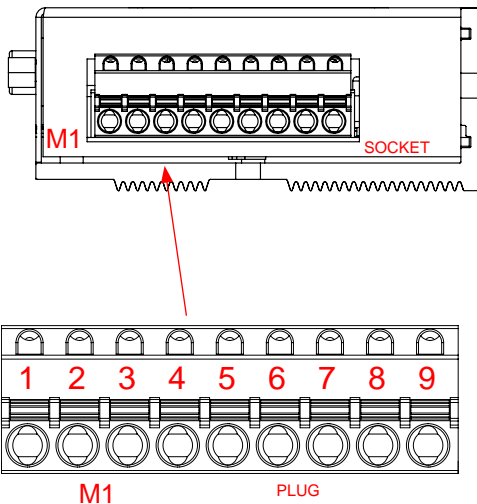

Pin	Signal Name	Description
1	Phase B-	Motor phase B-
2	Phase B	Motor phase B
3	Phase A-	Motor phase A-
4	Phase A	Motor phase A
5	Shield	Shield
6	Shield	Shield
7	Common Ground	Common ground reference
8	Power supply	DC power stage voltage input
9	Logic supply +24Vdc	+24Vdc supply of control stage

The SMD1204L is supplied with a DC voltage between 24Vdc and 65Vdc for the power stage and with a 24Vdc voltage for the logic stage.

The SMD1204H is supplied with a DC voltage between 24Vdc and 120Vdc for the power stage and with a 24Vdc voltage for the logic stage.

The separate power supply of the control stage with respect to the power stage permits to keep the axis control active even in case of emergency situations.

By feeding only the power stage, the logic stage will not be activated, and the drive will result switched off. Conversely, by feeding only the logic stage, the logic will be active, but it won't be possible to energize the phases of the motor.

It is recommended to use cables with minimum section of 1 mm² in case of connections of less than 20 m length, and section of 2,5 mm² in case of connection with greater lengths. (Maximum allowable length = 50 m).

Use cables with twisted pair shielded conductors.

Place the motor cable at a distance of at least 300 mm from signal cables (encoder, analog, high speed inputs).

Do not lock up or pass the motor cable in the same conduit of signal cables.

Provide grounding connection for motor housing.

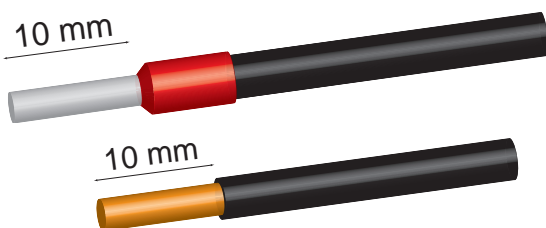

Conductor characteristics	mm ²
Conductor cross section solid	0,2 - 2,5
Conductor cross section stranded	0,2 - 2,5
Conductor cross section stranded, with ferrule without cable clip	0,2 - 2,5
Conductor cross section stranded, with ferrule with cable clip	0,2 - 2,5
Stripping length or cable lug length (mm)	10

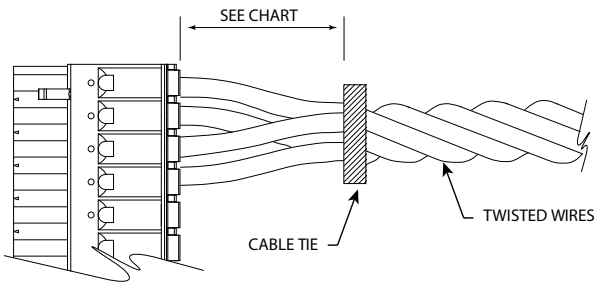

In case of twisted wires, fix the twist with a cable tie and let the cables free for the minimum distance you can see in the table.

Nr. of conductors	Minimum distance (mm)
2 - 8	12.7
10 - 16	19.1
18 - 24	25.4

DC voltage power supply

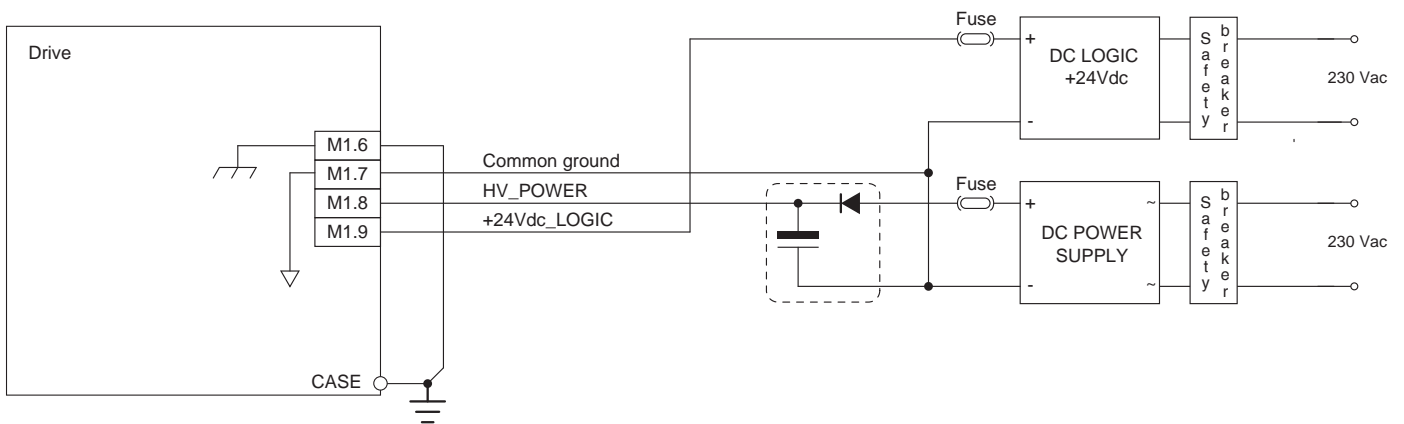

Diodes and capacitors must be installed in case the device is connected to a swithing power supply.

Specifications for ferrites and EMI shielding

In order to reduce EMI disturbances, it is required the installation of a ferrite filter on the cables of the motor phases, at a maximum distance of 150mm from the drive. The filter is composed of low-grade ferrite, which has high losses at radio frequencies. In this way the filter works as a high impedance at those frequencies

Recommended ferrites:

Manufacturer	FAIR-RITE	Würth Elektronik
Code	1463444	74271132
External diameter	23,7 mm	24,5 mm
Internal diameter	10,15 mm	8,5 mm
Lenght	39,4 mm	40,5 mm
Impedance at 25MHz	144 Ω	141 Ω
Impedance at 100 MHz	240 Ω	241 Ω

Typical wiring of a 4-wires motor

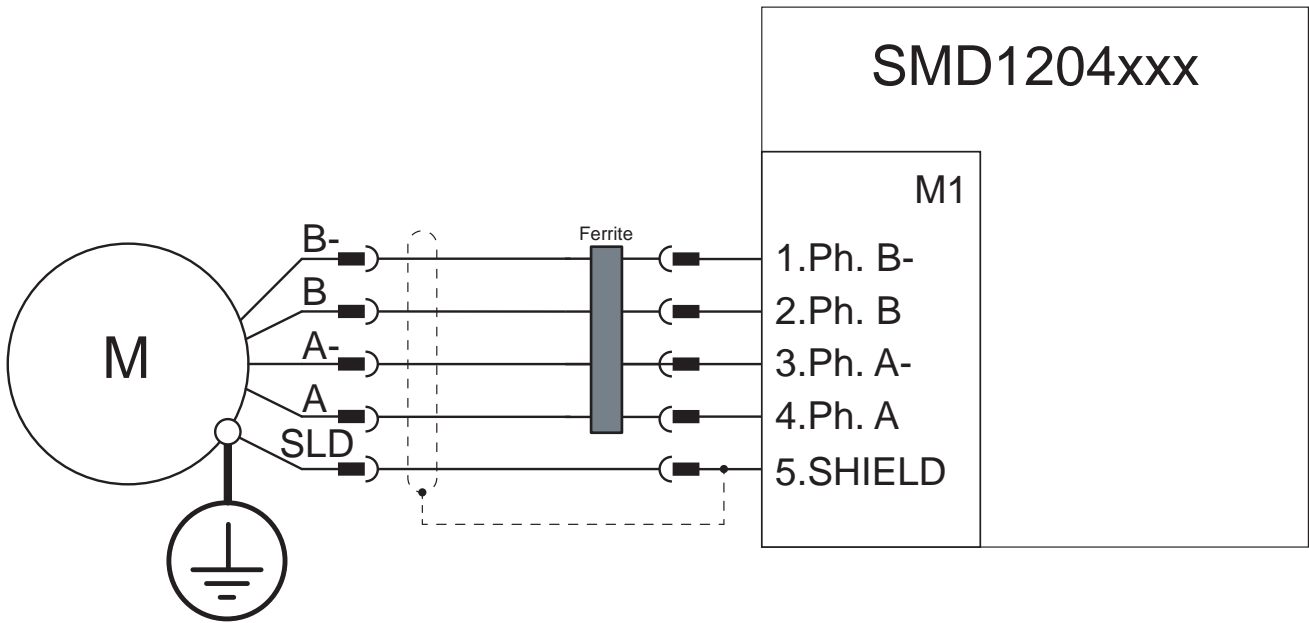

Other connection types

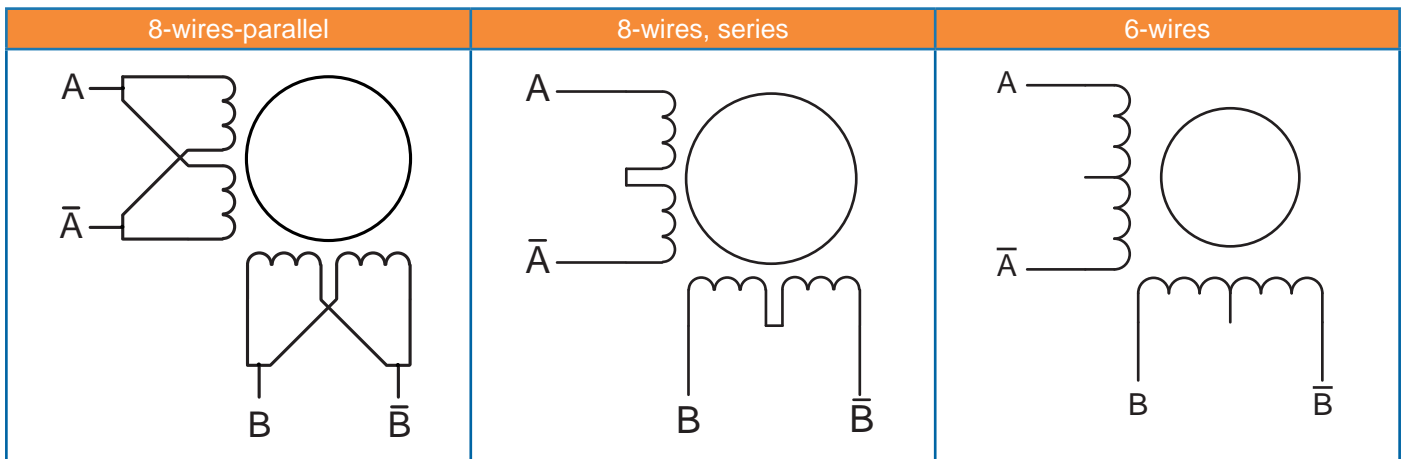

CURRENT CONTROL

The SMD1204 uses an advanced current control algorithm (REVC - Real-time Enhanced Vector control), developed by AEC thanks to the experience in stepper motor control.

The REVC permits to make a high performances field-oriented sinusoidal vector control, which eliminates some of the major limitations of stepper motors, such as:

- the noise at low speeds
- the vibrations due to the slip-stick movement of the rotor
- the high operating temperatures
- the eddy currents

The vector technology also permits to use the motor in Smart mode or Servo mode (closed loop), with the possibility to realize position, speed or torque loops, in addition to eliminating the possibility of synchronism loss.

POWER OUTPUT

		Min.	Typ.	Max.	Units
Nominal current	Discontinuous mode	-8,5		8,5	A _{PK}
	Continuous mode	-6		6	A _{RMS}
BOOST current	1 second max.	-8,5		8,5	A
Short-circuit current		-15		15	A

TYPES OF CONTROL

		Min.	Typ.	Max.	Units
PWM update	Frequency		20		KHz
	Time		50		µs
PWM type	Dual MOSFET H-bridges, 20 KHz center-weighted PWM field oriented space-vector modulation, based on DSP technology				
PWM ripple frequency			40		KHz
V _{BUS} compensation	V _{BUS} variations does not affect current control				

CONTROL CHARACTERISTICS

Type	Stepper mode	Current loop	Full digital
	Servo mode	Current loop	
		Velocity loop	
		Position loop	
Smart Mode	Current loop		
Sample time	Stepper mode	Current loop	20 KHz (50 µs)
	Servo mode	Current loop	20 KHz (50 µs)
		Velocity loop	4 KHz (250 µs)
		Position loop	1 KHz (1 ms)
	Smart Mode	Current loop	20 KHz (50 µs)
Compensazione V _{BUS}	V _{BUS} variations does not affect current control		

INPUTS/OUTPUTS INTERFACE

The SMD1204 drives are equipped with up to 10 general purpose digital inputs, up to 8 general purpose digital outputs, up to 3 analog inputs 0/+10V at 12 bit and 1 analog output 0/+10V at 10bit, which permit to interface with multiple external devices.

It is possible to connect encoders, limit-switches sensors, analog references, or in frequency, or use the i/o as general purpose, programming their functions.

Inputs are PNP type, and they accept input voltages between 5Vdc and 24Vdc without the use of external components. The outputs are PNP typer, adn they are protected against short-circuits.

DIGITAL INPUTS

The digital inputs can be read and configured with the software StepControl, or directly via Modbus RTU, CANopen, Profibus DP, Modbus TCP/IP, EtherCAT or Profinet.

Below are the internal registers associated with the inputs, and their functions:

- Rinp - read the state of the physical inputs
- Rhsinp - read the state of the high speed physical inputs
- Rfilinp - add a digital filter (input stabilization time)
- Renfinp - enable the digitla filter for each single input
- Rdefinp - define the activation state (active low/avtive high)
- Rmeminp - input activation memory (input latch)
- Rfuni0, Rfuni1, ... Rfuni9 - assign a funtion to the input (e.g. Axis homins, Alarm reset, JOG CW, JOG CCW, etc)

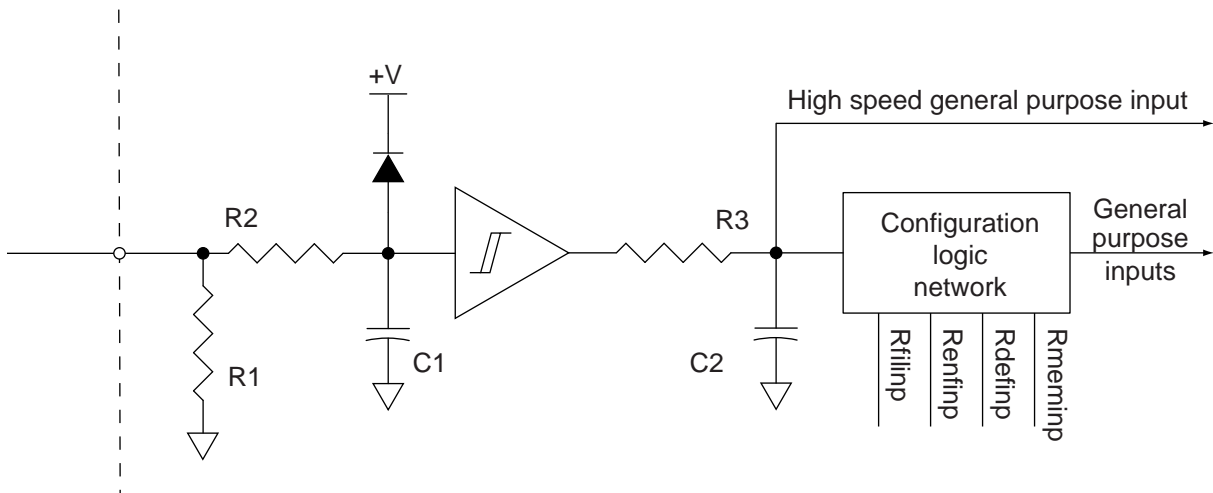

Type	Schmitt triggered with RC filter
Logic	PNP TTL compatible up to + 27 Vdc with internal pull-down
Scan time	1 ms for the register Rinp, 250 µs for the register Rhsinp
Digital filter	Programmable (0 - 16 ms) via Rfilinp and maskable (Renfinp)
Input threshold	Configurable via software at 2,5V or 12V
Active state	High or Low configurable by the user (Rdefinp)

		Min.	Typ.	Max.	Units
Input voltage	Logic state LOW	Configurable via software			V
	Logic state HIGH	Configurable via software			
	Maximum permitted values (500ms)	0		27	
Absorbed current	Logic state LOW		0,01		mA
	Logic state HIGH	0,1		1	
Frequency	Standard inputs		4		KHz

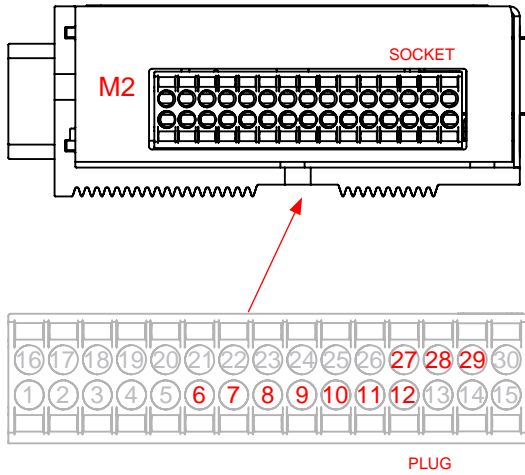

Caution!!! Some inputs share the same pinout with other signals. In order to avoid damages to the connected devices, never active an output when the same pin is used as an input.

Pin	Signal Name	Description
1	+5 V _{DC} out	+5V _{DC} output (100mA max.)
2	Common encoder	Encoder inputs common
3	Motor encoder A-	Motor encoder A- channel
4	Motor encoder B-	Motor encoder B- channel
5	Motor encoder Z-	Motor encoder Z- channel
6	Input 5	General purpose input nr. 5
7	Input 6	General purpose input nr. 6
8	Input 7	General purpose input nr. 7
9	Input 8	General purpose input nr. 8
10	Input 9	General purpose input nr. 9
11	Input 0	General purpose input nr. 0
12	Input 1	General purpose input nr. 1
13	Output 0	General purpose output nr. 0
14	+5 V _{DC} out	+5V _{DC} output (100mA max.)
15	Common	Digital inputs common
16	+5 V _{DC} out	+5V _{DC} output (100mA max.)
17	Common encoder	Encoder inputs common
18	Digital Output 5	Digital output 5
19	Analog output	Analog output
20	Analog Common	Analog in/out common
21	Analog Input	Analog input
22	Ana.Inp.1 / Dig.Out. 2	Analog input 1 / Digital output 2
23	Ana.Inp.2 / Dig.Out. 3	Analog input 2 / Digital output 3
24	External encoder A-	External encoder A- channel
25	External encoder B-	External encoder B- channel
26	External encoder Z-	External encoder Z- channel
27	Input 2	General purpose input nr. 2
28	Input 3	General purpose input nr. 3
29	Input 4	General purpose input nr. 4
30	Digital Output 1	Digital output 1



Disable the output current to the motor before making any modification, either electric or configuration, to the inputs. Failure to observe this rule may result in unexpected movements of the motors, with consequent damages or injuries.

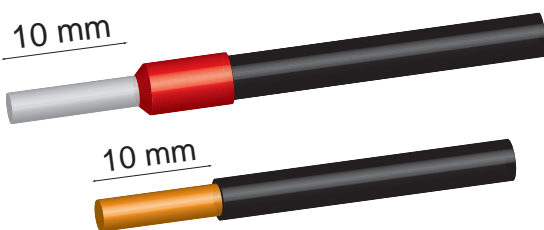

Conductor characteristics	mm ²
Conductor cross section solid	0,2 - 1,5
Conductor cross section stranded	0,2 - 1,5
Conductor cross section stranded, with ferrule without cable clip	0,2 - 1,5
Conductor cross section stranded, with ferrule with cable clip	0,2 - 0,75
Stripping lenght or cable lug lenght (mm)	10

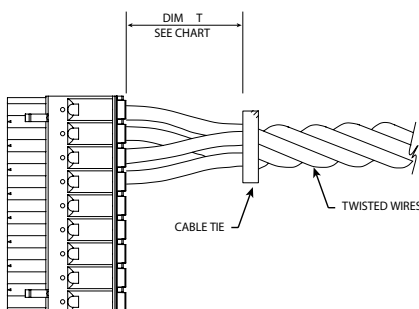

In case of twisted wires, fix the twist with a cable tie e let the cables free for the minimum distance you can see in the table.

Nr. of conductors	Minimum distance (mm)
2 - 8	12.7
10 - 16	19.1
18 - 24	25.4

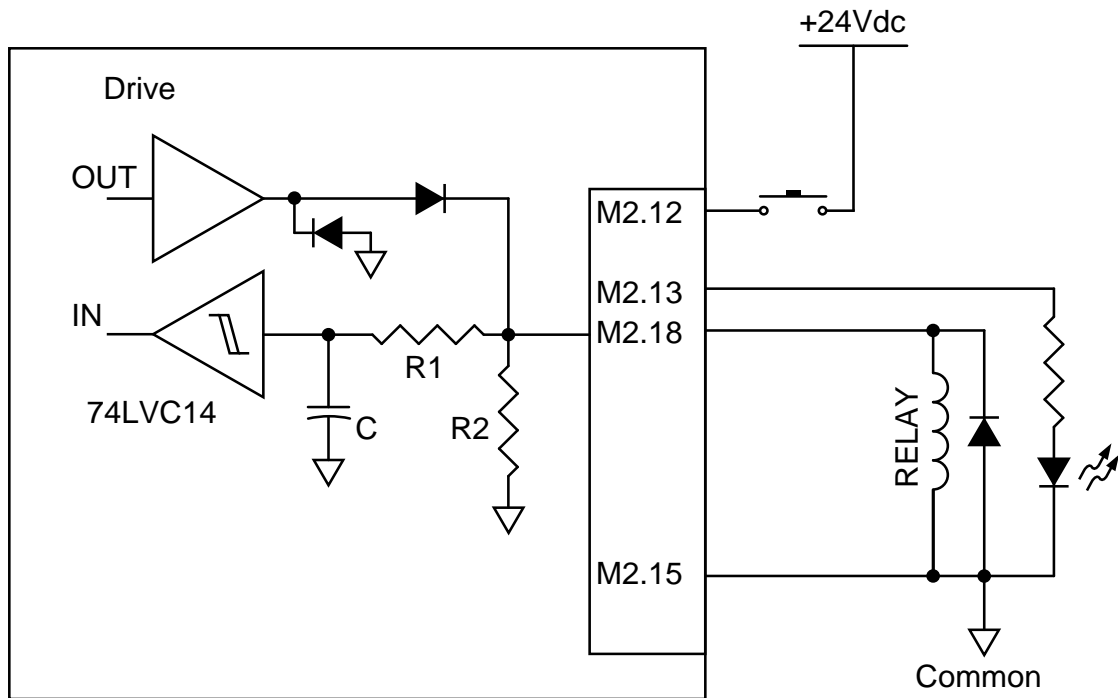

Caution!!! In case you need to drive inductive loads (like relays, electro-valves, etc.) connect a flyback diode (1A @1000V) in parallel to the load.

Place the motor cable at a distance of at least 300 mm from signal cables (encoder, analogic, fast inputs). Do not lock up or pass the motor cable in the same conduit of signal cables.

DIGITAL OUTPUTS

The digital outputs can be read, configured and enabled with the software StepControl, or directly via Modbus RTU, CANopen, Profibus DP, Modbus TCP, EtherCAT or Profinet.

Below are the internal registers associated with the outputs, and their functions:

- Rout - change or read the state
- Rdefout - define the activation state (active low/active high)
- Rfuno0, Rfuno1 - assign a function to the output (e.g. Synchronized axis, motor in movement, alarm)

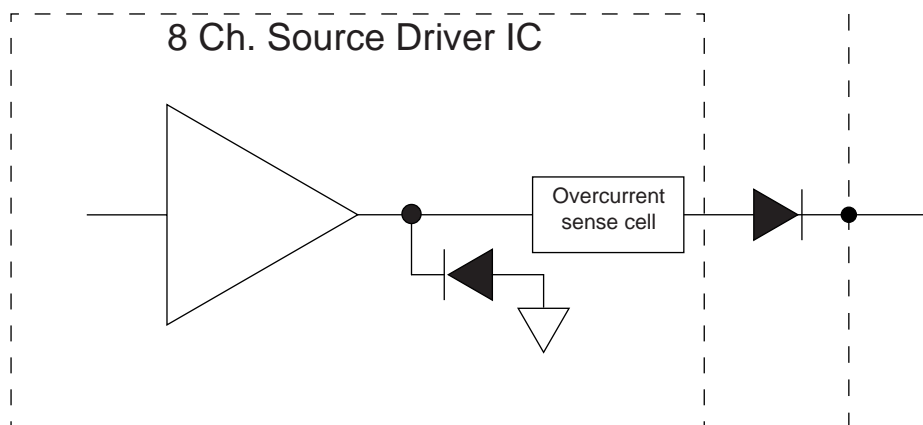

		Min.	Typ.	Max.	Units
Operating voltage		7	24	27	V
Output voltage			$V_{PWR} - 2$		V
Overcurrent protection			200		mA
T_{FAULT} intervention delay				< 1	μ s
Propagation time	T_{PLH} $R_L = 100 \Omega$		0,3	0,6	μ s
	T_{PHL} $R_L = 100 \Omega$		2,0	4,0	



In case an output is overloaded, the output is automatically switched off by the drive; after about 1 second it is re-activated and, in case of persistent overload, it is switched off again. This procedure is carried out three times before generating an output stage overload alarm (bit 5 of the register Ralarm).

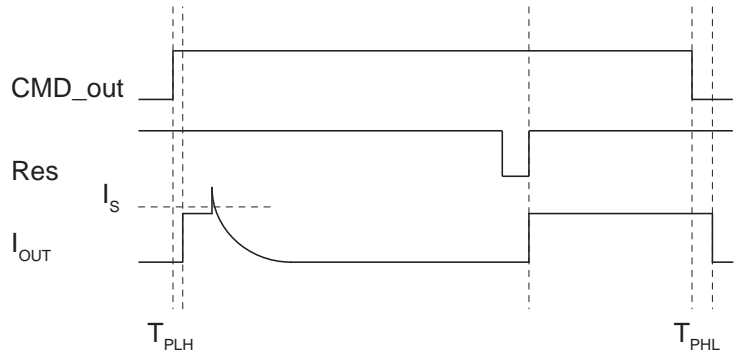

Behavior of an output in case of overload

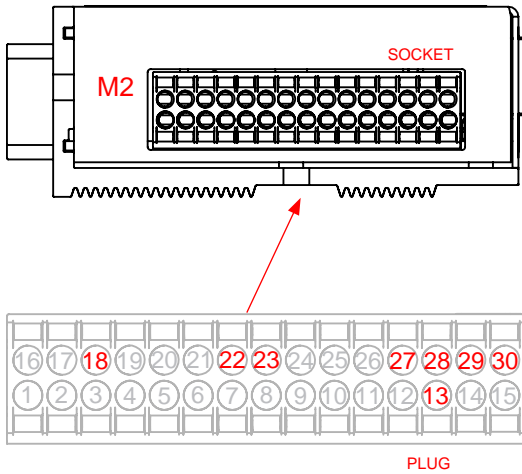

Caution!!! *Some outputs share the same pinout with other signals. In order to avoid damages to the connected devices, never active an input when the same pin is used as an output.*

Pin	Signal Name	Description
1	+5 V _{DC} out	+5V _{DC} output (100mA max.)
2	Common encoder	Encoder inputs common
3	Motor encoder A-	Motor encoder A- channel
4	Motor encoder B-	Motor encoder B- channel
5	Motor encoder Z-	Motor encoder Z- channel
6	Input 5	General purpose input nr. 5
7	Input 6	General purpose input nr. 6
8	Input 7	General purpose input nr. 7
9	Input 8	General purpose input nr. 8
10	Input 9	General purpose input nr. 9
11	Input 0	General purpose input nr. 0
12	Input 1	General purpose input nr. 1
13	Output 0	General purpose output nr. 0
14	+5 V _{DC} out	+5V _{DC} output (100mA max.)
15	Common	Digital inputs common
16	+5 V _{DC} out	+5V _{DC} output (100mA max.)
17	Common encoder	Encoder inputs common
18	Digital Output 5	Digital output 5
19	Analog output	Analog output
20	Analog Common	Analog in/out common
21	Analog Input	Analog input
22	Digital Output 2	Digital output 2
23	Digital Output 3	Digital output 3
24	External encoder A-	External encoder A- channel
25	External encoder B-	External encoder B- channel
26	External encoder Z-	External encoder Z- channel
27	Digital Output 6	Digital output 6
28	Digital Output 7	Digital output 7
29	Digital Output 4	Digital output 4
30	Digital Output 1	Digital output 1

SERVICE INPUTS

The service inputs are high speed digital inputs that can be read and configured with the software StepControl, or directly via Modbus RTU, CANopen, Profibus DP, Modbus TCP/IP, EtherCAT or Profinet.

Below are the internal registers associated with the service inputs, and their functions:

Rlsi	- read the state of the physical inputs
Rhlsi	- read the state of the high speed physical inputs
Rfillsi	- add a digital filter (input stabilization time)
Renflsi	- enable the digital filter for each single input
Rdeflsi	- define the activation state (active low/active high)
Rmemlsi	- input activation memory (input latch)
Rencext	- encoder inputs value in quadrature

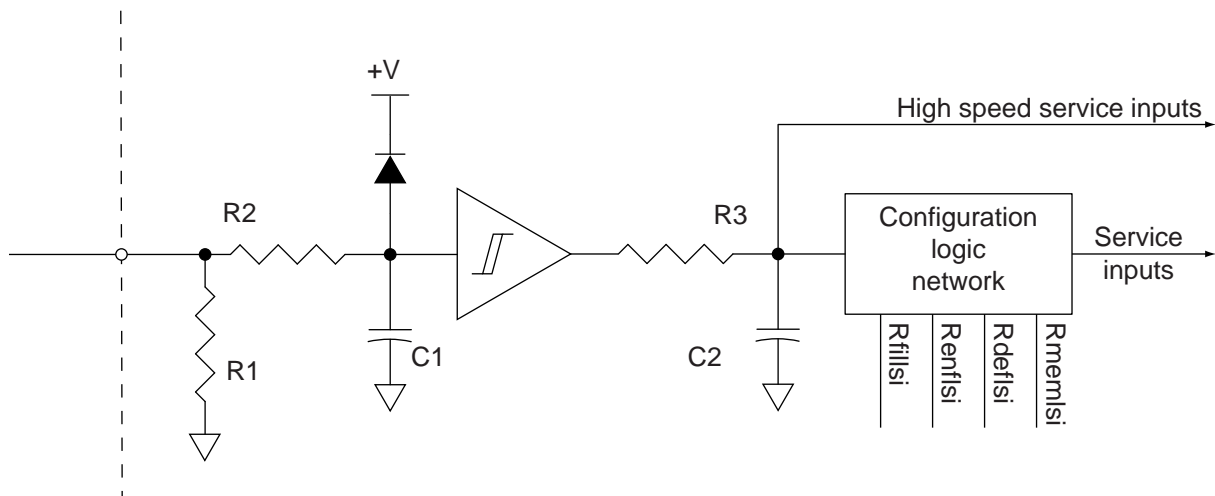

Type	Schmitt triggered with RC filter
Logic	PNP TTL up to + 27 Vdc with internal pull-down
Scan time	real-time input capture, 1 ms for the register Rlsi, 250 µs for the register Rhlsi
Digital filter	Programmable (0 - 16 ms) via Rfillsi and maskable (Renflsi)
Active state	High or Low configurable by the user (Rdeflsi)

		Min.	Typ.	Max.	Units
Input voltage	Logic state LOW	0	0	1,2	V
	Logic state HIGH	2,4	5 / 24	27	
Absorbed current	Logic state LOW		0,01		mA
	Logic state HIGH	0,1		1	
Frequency	Service inputs			70	KHz



Disable the output current to the motor before making any modification, either electric or configuration, to the inputs. Failure to observe this rule may result in unexpected movements of the motors, with consequent damages or injuries.

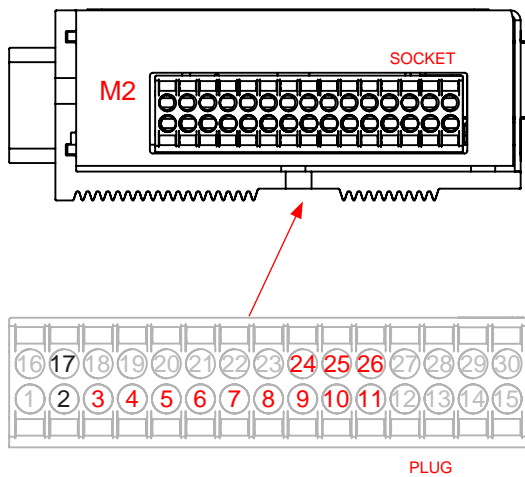

Caution!!!

The +5Vdc output can be used only to supply the encoders, and it has an output maximum capacity of 100mA. In case of overload the output protects itself by limiting the supplied current.

Notes:

The encoder inputs can be connected both in single ended mode (NPN or PNP) and in Line Driver, and they accept input voltages between +5Vdc and +24Vdc. The BLS and FLS inputs are single ended PNP inputs, and they accept input voltages between +5Vdc and +24Vdc.

Pin	Signal Name	Description
1	+5 V _{DC} out	+5V _{DC} output (100mA max.)
2	Common encoder	Encoder inputs common
3	Motor encoder A-	Motor encoder A- channel
4	Motor encoder B-	Motor encoder B- channel
5	Motor encoder Z-	Motor encoder Z- channel
6	Motor encoder A+	Canale A+ encoder motore
7	Motor encoder B+	Canale B+ encoder motore
8	Motor encoder Z+	Canale Z+ encoder motore
9	External encoder A+ / FLS	Canale A+ encoder esterno / Finecorsa avanti
10	External encoder B+ / BLS	Canale B+ encoder esterno / Finecorsa indietro
11	External encoder Z+	Canale Z+ encoder esterno
12	Input 1	General purpose input nr. 1
13	Output 0	General purpose output nr. 0
14	+5 V _{DC} out	+5V _{DC} output (100mA max.)
15	Common	Digital inputs common
16	+5 V _{DC} out	+5V _{DC} output (100mA max.)
17	Common encoder	Encoder inputs common
18	Digital Output 5	Digital output 5
19	Analog output	Analog output
20	Analog Common	Analog in/out common
21	Analog Input	Analog input
22	Ana.Inp.1 / Dig.Out. 2	Analog input 1 / Digital output 2
23	Ana.Inp.2 / Dig.Out. 3	Analog input 2 / Digital output 3
24	External encoder A-	External encoder A- channel
25	External encoder B-	External encoder B- channel
26	External encoder Z-	External encoder Z- channel
27	Digital Output 6	Digital output 6
28	Digital Output 7	Digital output 7
29	Digital Output 4	Digital output 4
30	Digital Output 1	Digital output 1

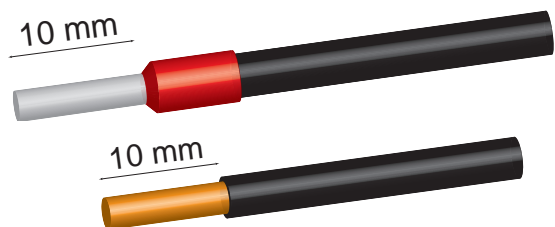
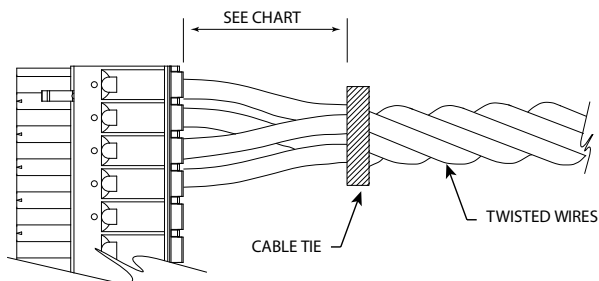

In case of twisted wires, fix the twist with a cable tie and let the cables free for the minimum distance you can see in the table.

Nr. of conductors	Minimum distance (mm)
2 - 8	12.7
10 - 16	19.1
18 - 24	25.4

Conductor characteristics	mm ²
Conductor cross section solid	0,2 - 1,5
Conductor cross section stranded	0,2 - 1,5
Conductor cross section stranded, with ferrule without cable clip	0,2 - 1,5
Conductor cross section stranded, with ferrule with cable clip	0,2 - 0,75
Stripping length or cable lug length (mm)	10

Motor encoder connection examples:

- Line Driver connection

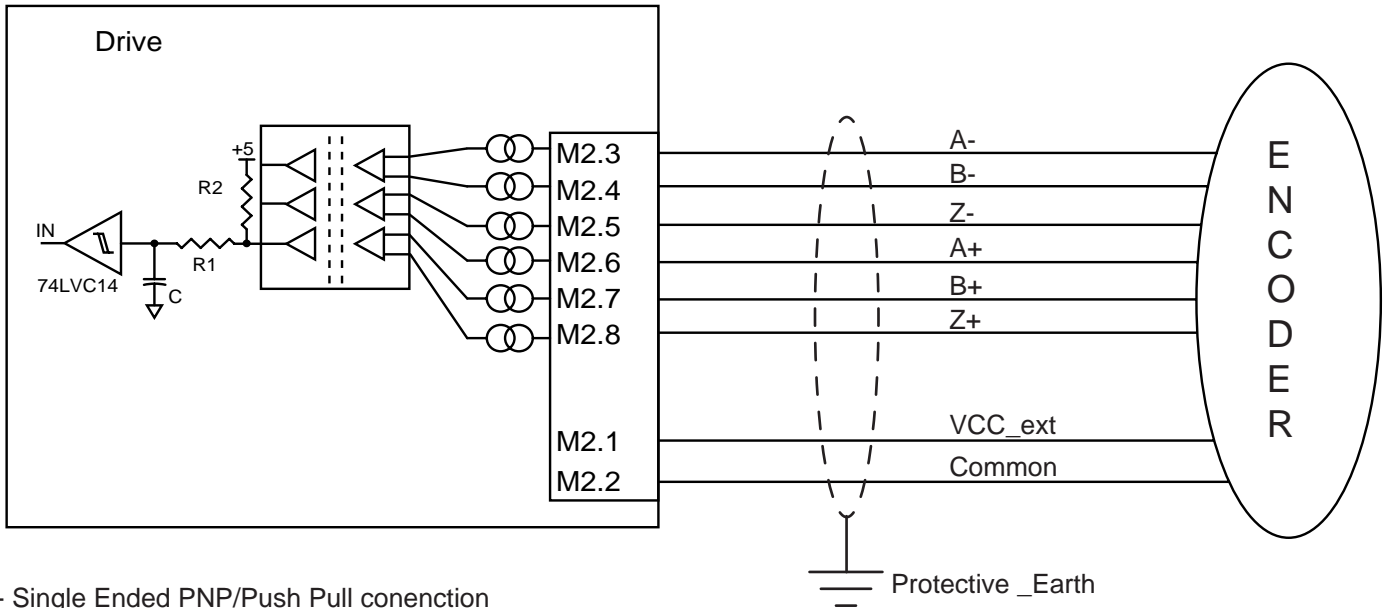

- Single Ended PNP/ Push Pull connection

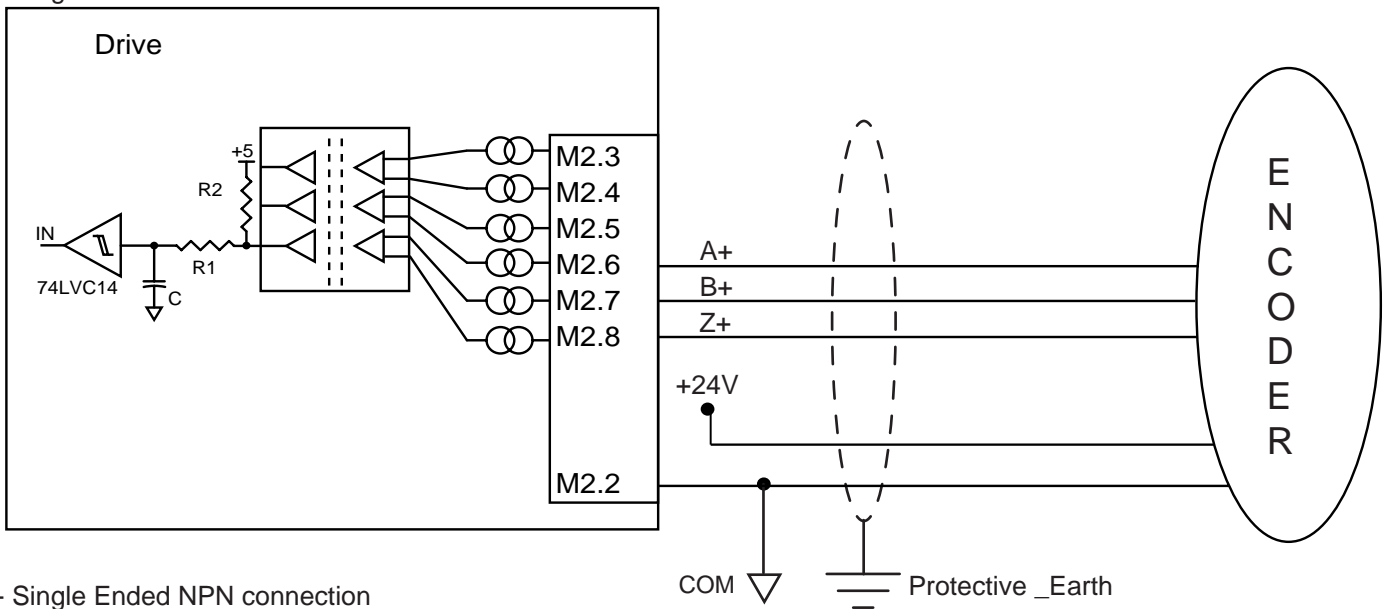

- Single Ended NPN connection

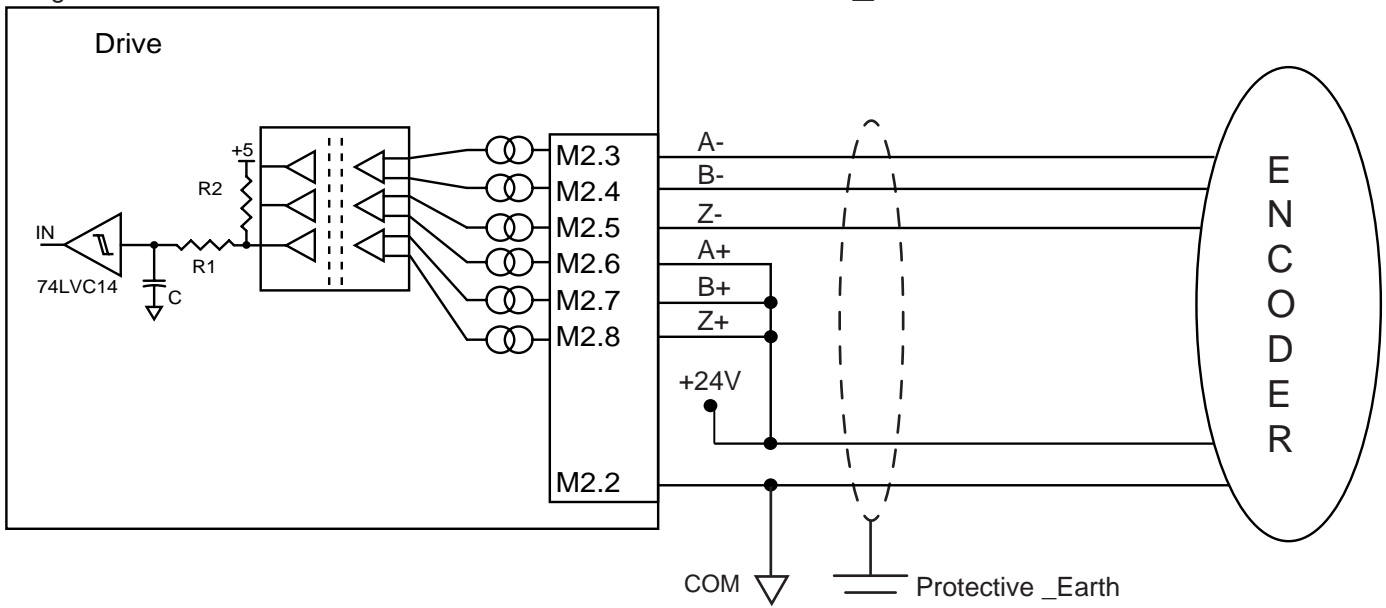

1 Place the motor cable at a distance of at least 300 mm from signal cables (encoder, analogic, fast inputs). Do not lock up or pass the motor cable in the same conduit of signal cables.

Limit switch connection example:

- Limit switch connection

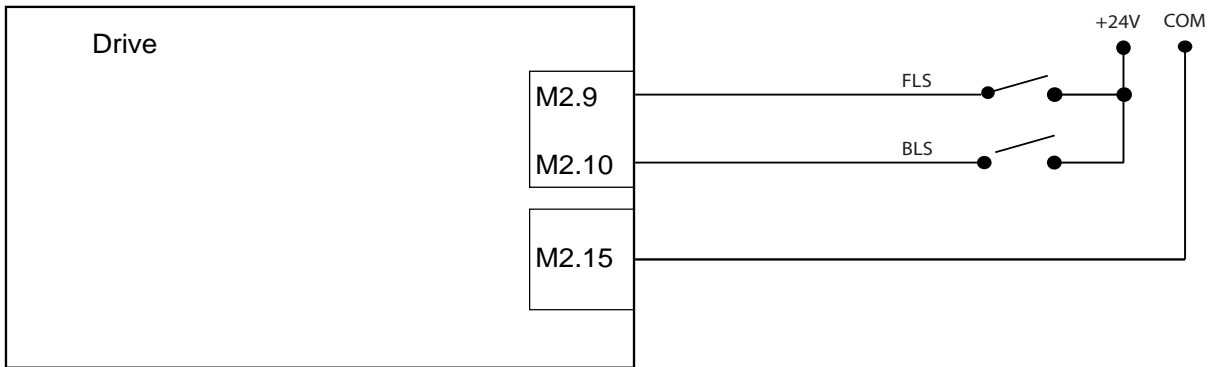

ANALOG INPUTS

The SMD1204 has three single-ended type 0 - 10Vdc analog inputs.

The conversion stage is composed by a 12MSPS Sample&Hold type 12-bit high speed A/D converter, with conversion time of 80ns.

The acquired value can be read and configured with the software StepControl, or directly via Modbus RTU, CANopen, Profibus DP, Modbus TCP/IP, EtherCAT or Profinet.

Below are the internal registers associated with the analog inputs, and their functions:

- Ranainp - read the value of the analog input
- Rmulainp - condition the value read from the analog input (multiplication factor)
- Rshiftainp - condition the value read from the analog input (division factor)
- Ranaidb - set a dead band
- Ranaofs - set an offset
- Rdefainp - assign a function to the analog input (e.g. Position reference, Velocity reference, etc...)

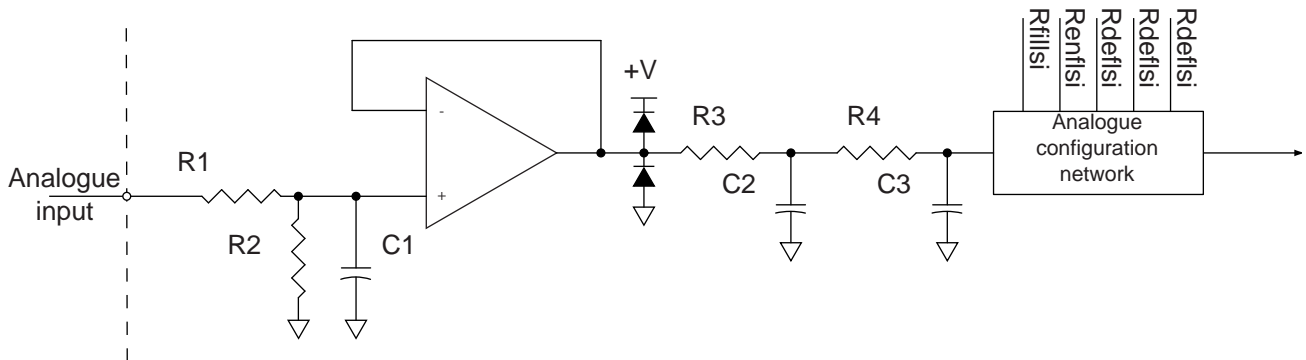

Type	0 - 10 Vdc single ended
Conversion	12MSPS high speed Sample&Hold
Scan time	1ms
Conditioning	Dead-band (Ranaidb) and programmable offset (Ranaofs)
Function	Programmable via Rdefainp

	Min.	Typ.	Max.	Units
Measure range	0		10	V
Input impedance	100			K Ω
Input voltage			12	Vdc
LSB value		2.44		mVdc
Resolution		12		bit
Conversion time		80		ns
Scan time		1		ms
Temperature coefficient		50		PPM/°C
Linearity error		±1		LSB

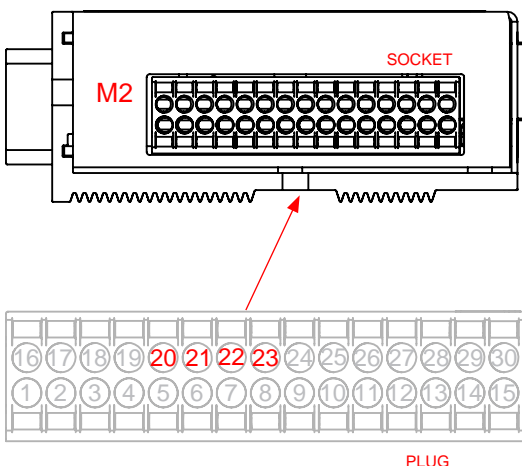

Pin	Symbol	Signal Name	Description
20	Analog Common	Analog in/out common	Analog inputs common
21	Analog Input	Analog input	Analog input
22	Digital Output 2	Digital output 2	Analog input 1
23	Digital Output 3	Digital output 3	Analog input 2

ANALOG OUTPUT

The SMD1204xxx has one single-ended type 0 - 10Vdc analog output.

The conversion stage is composed by a 10bit high speed A/D converter/ 187kSPS and conversion time of 250ns.

The acquired value can be read and configured with the software StepControl, or directly via Modbus RTU, Modbus TCP, CANopen, Profibus, EtherCAT or Profinet.

Below are the internal registers associated with the analog output, and their functions:

- Ranaout - read the value
- Rmulanaout - condition the value read from the analog output (multiplication factor)
- Rshiftanaout - condition the value read from the analog output (division factor)
- Rofsanaout - set an offset
- Rdefanaout - assign a function to the analog output (position/velocity/current reference, etc...)

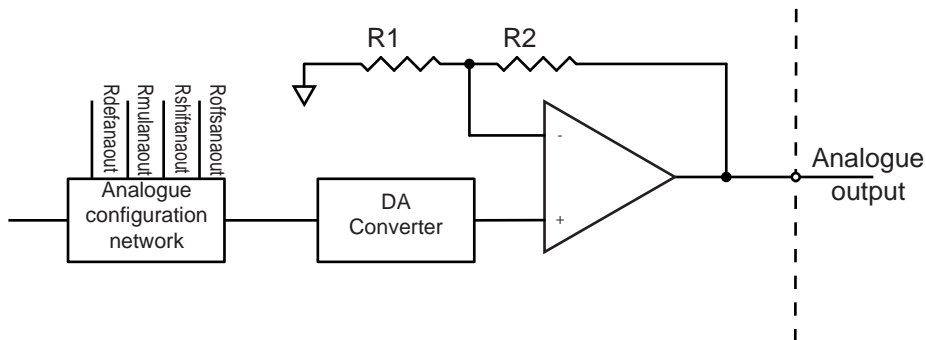

Tipo	0 - 10 Vdc single ended
Conversione	DA holded
Tempo di aggiornamento	1ms
Condizionamento	Multiplier (Rmulanaout) Divider (Rshiftanaout) and programmable offset (Ranaofs)
Functions	Programmable (Rdefanaout)

	Min.	Typ.	Max.	Units
Measure range	0		10	V
Input impedance		1		Ω
Zero error		5	20	mVdc
Resolution	10			bit
Conversion delay		7	9	μ s
Scan time		1		ms
Short-circuit current		20		mA
Linearity error		-0.15	-1.25	% FSR

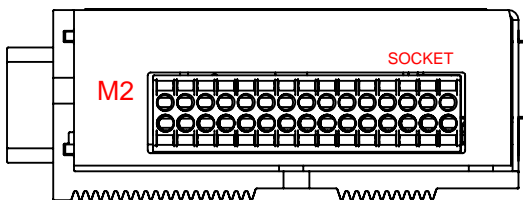

Pin	Signal Name	Description
19	Analog Output	Analog output
20	Analog Common	Analog I/O common

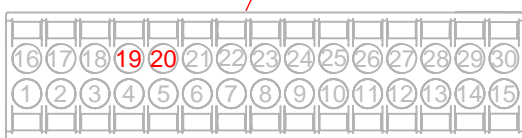

PLUG

MOTOR CONNECTION CABLES

CONV05Fxx7/8Cxxx

Shielded dynamic laying cables for stepper motors series M86SHxx and M110SHxx.

SPECIFICATIONS	UM	
Temperature range (flexible installation)	°C	-30 .. +80
Temperature range (fixed installation)	°C	-40 .. +80
Stranding	nr x mm	cl 6
Minimum bending radius	mm	10 x Ø
Nominal voltage	V	300
Sheath material		Opaque PUR Halogenfree
Insulation material		PP 9Y Halogenfree
Bending cycles		> 2 millions
Maximum acceleration	m/s ²	2
Maximum translation speed	m/min	200

Model	Connector	Nr. of conductors	Cross section	Characteristics	External diameter	Length
		N	mm ²			
CONV05FDR7/8C12SU100	Straight	4 + 1	1,00	UL-CSA 300 V 80°C	7,4	12
CONV05FDR7/8C04SU100	Straight	4 + 1	1,00	UL-CSA 300 V 80°C	7,4	4
CONV05F907/8C12SU100	Angled	4 + 1	1,00	UL-CSA 300 V 80°C	7,4	12
CONV05F907/8C04SU100	Angled	4 + 1	1,00	UL-CSA 300 V 80°C	7,4	4

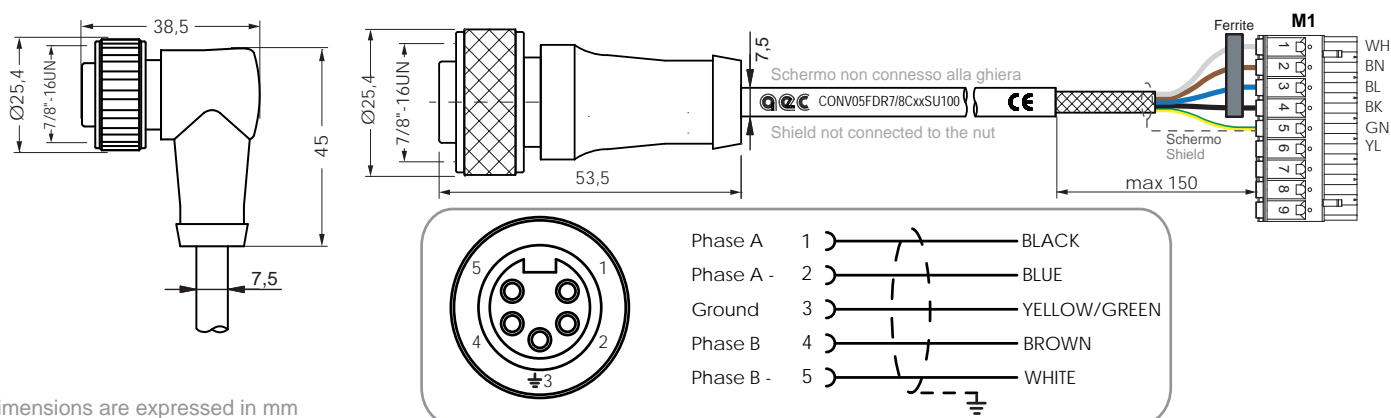

Caution!!!

Don't connect or disconnect the circular connector or the terminal block in presence of voltage. The connection in presence of voltage may result in electrical discharges that are potentially harmful to the equipment, the connectors and the user.



Caution!!!

Don't install cables with bending radius lower than those indicated; avoid the contact with sharp edges or abrasive surfaces. Periodically check the integrity of the insulating sheath.

CONV05FxxM12Cxxx

Shielded dynamic laying cables for stepper motors series M42SHxx, M57SHxx and M60SHxx.

SPECIFICATIONS	UM	
Temperature range (flexible installation)	°C	-15 .. +80
Temperature range (fixed installation)	°C	-30 .. +80
Minimum bending radius	mm	10 x Ø
Nominal voltage	V	300
Sheath material		TPE-U (PUR) oil resistant DIN EN 60811-2-1
Insulation material		PP 9Y
Bending cycles		> 2 millions
Maximum acceleration	m/s ²	5
Maximum translation speed	m/min	200

Model	Connector	Nr. of conductors	Cross section	Characteristics	External diameter	Length
		N	mm ²		mm	m
CONV05FDRM12C04SU034	Straight	5	0,25	UL20549	5,8	4
CONV05FDRM12C12SU034	Straight	5	0,25	UL20549	5,8	12
CONV05F90M12C04SU034	Angled	5	0,25	UL20549	5,8	4
CONV05F90M12C12SU034	Angled	5	0,25	UL20549	5,8	12

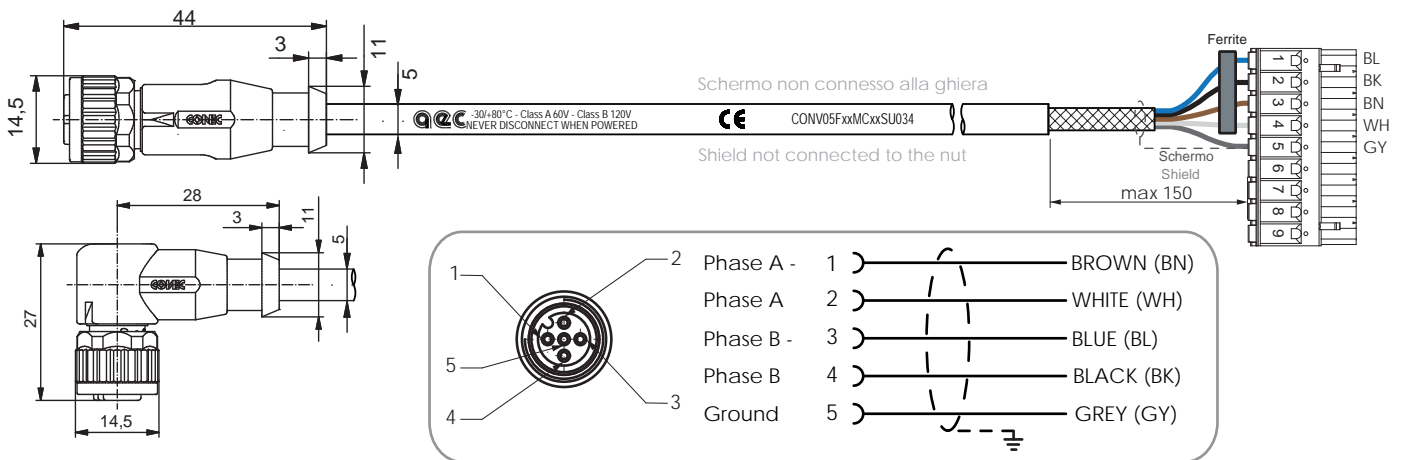

Caution!!!

Don't connect or disconnect the circular connector or the terminal block in presence of voltage. The connection in presence of voltage may result in electrical discharges that are potentially harmful to the equipment, the connectors and the user.



Caution!!!

Don't install cables with bending radius lower than those indicated; avoid the contact with sharp edges or abrasive surfaces. Periodically check the integrity of the insulating sheath.

ENCODER CONNECTION CABLES

CONV05MxxM12Cxxx

Shielded dynamic laying cables for AEC integrated Push Pull encoders.

SPECIFICATIONS	UM	
Temperature range (flexible installation)	°C	-15 .. +80
Temperature range (fixed installation)	°C	-30 .. +80
Minimum bending radius	mm	10 x Ø
Nominal voltage	V	300
Sheath material		TPE-U (PUR) oil resistant DIN EN 60811-2-1
Insulation material		PP 9Y
Bending cycles		> 2 millions
Maximum acceleration	m/s ²	5
Maximum translation speed	m/min	200

Model	Connector	Nr. of conductors	Cross section	Characteristics	External diameter	Length
		N	mm ²			
CONV05MDRM12C04SU025	Straight	5	0,25	UL20549	5,5	4
CONV05MDRM12C12SU025	Straight	5	0,25	UL20549	5,5	12
CONV05M90M12C04SU025	Angled	5	0,25	UL20549	5,5	4
CONV05M90M12C12SU025	Angled	5	0,25	UL20549	5,5	12

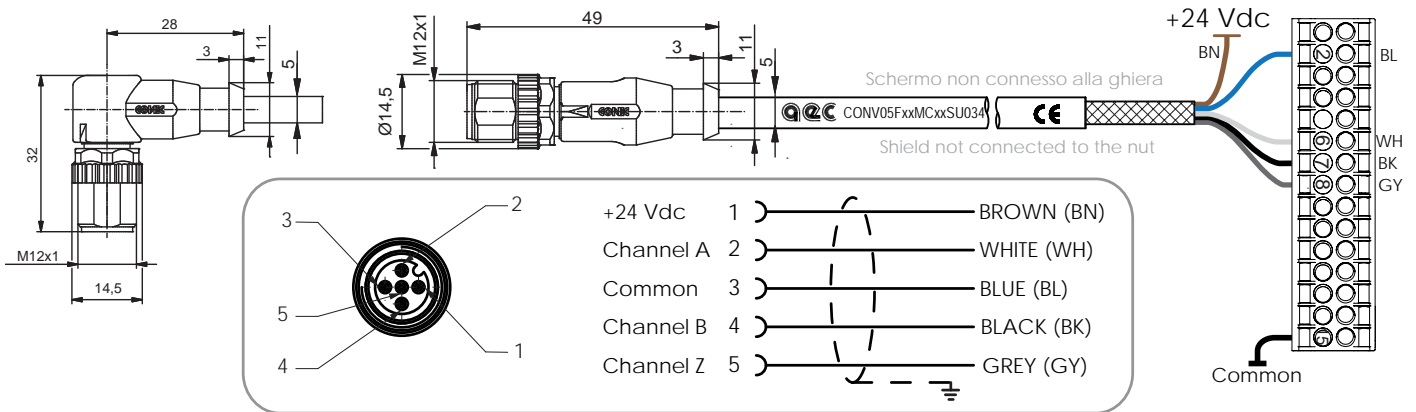

Caution!!!

Don't connect or disconnect the circular connector or the terminal block in presence of voltage. The connection in presence of voltage may result in electrical discharges that are potentially harmful to the equipment, the connectors and the user.



Caution!!!

Don't install cables with bending radius lower than those indicated; avoid the contact with sharp edges or abrasive surfaces. Periodically check the integrity of the insulating sheath.

CONV08FxxM12Cxxx

Shielded dynamic laying cables for AEC integrated Line Driver encoders.

SPECIFICATIONS	UM	
Temperature range (flexible installation)	°C	-15 .. +80
Temperature range (fixed installation)	°C	-30 .. +80
Minimum bending radius	mm	10 x Ø
Nominal voltage	V	300
Sheath material		TPE-U (PUR) oil resistant DIN EN 60811-2-1
Insulation material		PP 9Y
Bending cycles		> 2 millions
Maximum acceleration	m/s ²	5
Maximum translation speed	m/min	200

Model	Connector	Nr. of conductors	Cross section	Characteristics	External diameter	Length
		N	mm ²			
CONV08FDRM12C04SU025	Straight	8	0,25	UL20549	5,5	4
CONV08FDRM12C12SU025	Straight	8	0,25	UL20549	5,5	12
CONV08F90M12C04SU025	Angled	8	0,25	UL20549	5,5	4
CONV08F90M12C12SU025	Angled	8	0,25	UL20549	5,5	12

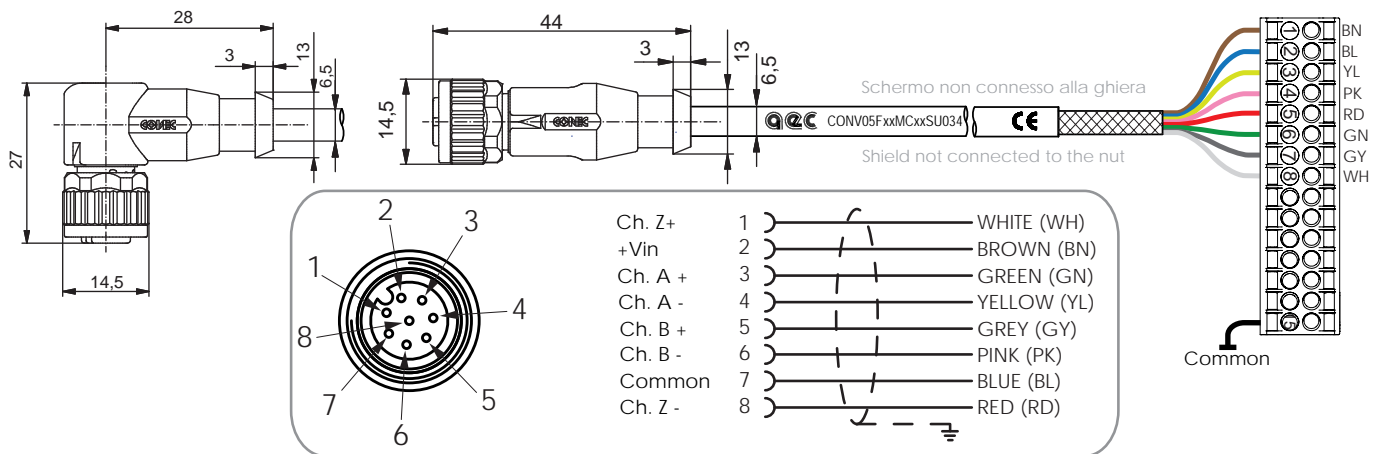

Caution!!!

Don't connect or disconnect the circular connector or the terminal block in presence of voltage. The connection in presence of voltage may result in electrical discharges that are potentially harmful to the equipment, the connectors and the user.



Caution!!!

Don't install cables with bending radius lower than those indicated; avoid the contact with sharp edges or abrasive surfaces. Periodically check the integrity of the insulating sheath.

COMMUNICATION INTERFACE

The SMD1204 drives are provided with multiple communication channels, which permit to connect with external devices by using widespread standard protocols.

All the products of the family are able to communicate with a USB connection, which is used to parameterize, configure and program the axis controller.

In addition to the standard USB communication channel, it is possible to have other communication lines: Modbus RTU (SMD1204xxM), CANopen (SMD1204xxC), Profibus DP (SMD1204xxP), Modbus TCP/IP (Model SMD1204xxE), EtherCAT (Model SMD1204xxT) or Profinet (Model SMD1204xxN).

These solutions allow the drive to communicate with all control devices (PC, PLC) or visualization devices (HMI) available on the market, in a simple and quick way.

USB INTERFACE



Type	Full Speed USB 2.0 Composite Device CDC
Number of channels	1
Insulation	-
Functions	Configuration and parameterization, programming, diagnostic and remote control

		Min.	Typ.	Max.	Units
Signals	V_{BUS} , D+, D-, GND				
Baudrate	Fixed		9600		Baud
Parity	Fixed		NONE		
Number of bit	Fixed		8		
Stop bit number	Fixed		1		bit
Protocol			Modbus RTU		
ESD Protection	Human Body Model		± 15		kV

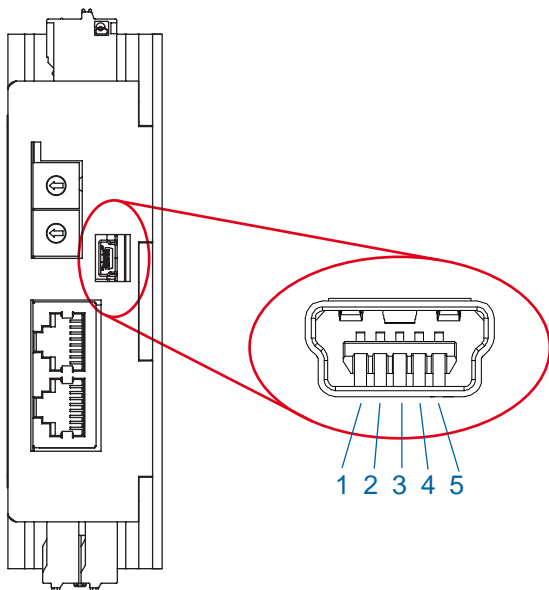

Pin	Symbol	Signal Name	Description
1	V_{BUS}	Bus Voltage	USB port power supply
2	D-	Data -	USB channel Data -
3	D+	Data +	USB channel Data +
4	NC	Not Connected	Not connected
5	GND	Comune TX	Communication signals common

Type	TIA/EIA-232-F e ITUv.28
Number of channels	1
Insulation	High speed (25Mbps) capacitive digital insulator
Functions	Configuration and parameterization, programming, diagnostic and remote control
Connector	DB9 or RJ45
Dimension of the conductor	30 AWG

		Min.	Typ.	Max.	Units
Signals	TXD, RXD, GND				
Baudrate	Configurable (<i>Rserbaud</i>)	1200	9600	115200	Baud
Parity	Configurable (<i>Rserpar</i>)	EVEN, NONE, ODD			
Number of bit	Fixed	8			
Bit stop number	Configurable (<i>Rserpar</i>)	1	1	2	bit
Protocol		Modbus RTU			
ESD protection	Human Body Model		±15		kV

RJ45 connector version

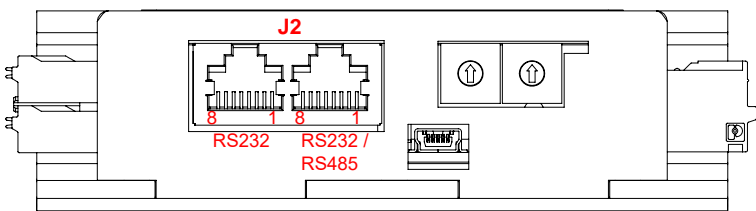

DB9 connector version

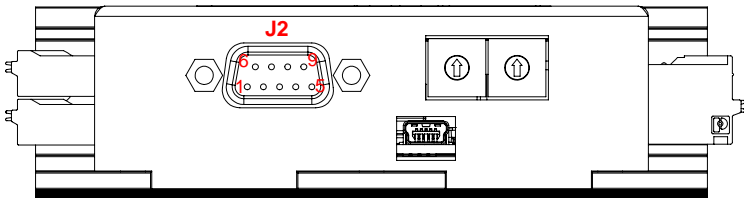

Pin	Signal Name	Description
1	Shield	Shield
2	Data TX	Data RS-232C in trasmission
3	Data RX	Data RS-232C in reception
4	Not Connected	Not connected
5	Comune TX	Communication signals common
6	Not Connected	Not connected
7	Data +	RS-485 Data +
8	Data -	RS-485 Data -
9	Comune TX	Communication signals common

Caution!!!

The VCC ext signal is an insulated voltage with respect to the power supply. VCC ext can be used only to connect the pull-up resistance on the line D+.

In case of overload the output protects itself by limiting the current supplied.

Place the motor cable at a distance of at least 300 mm from signal cables (encoder, analogic, fast inputs) or communication calbes. Do not lock up or pass the motor cable in the same conduit of signal cables.

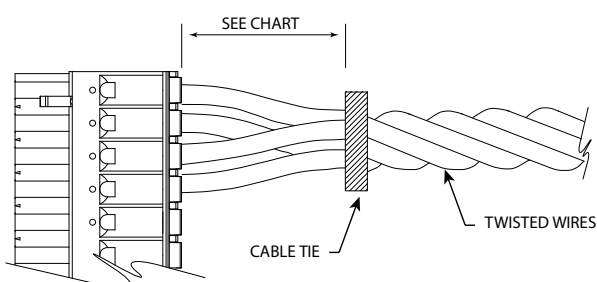

In case of twisted wires, fix the twist with a cable tie e let the cables free for the minimum distance you can see in the table.

Nr. of conductors	Minimum distance (mm)
2 - 8	12.7
10 - 16	19.1
18 - 24	25.4

RS-485 SERIAL INTERFACE (SMD1204xxM)

Type	TIA/EIA-485A				
Number of channels	1				
Insulation	High speed capacitive digital insulator (25Mbps)				
Functions	Configuration and parameterization, programming, diagnostic and remote control				
		Min.	Typ.	Max.	Units
Signals	D+, D-, GND				
Baudrate	Configurable (<i>Rserbaud</i>)	1200	9600	115200	Baud
Parity	Configurable (<i>Rserpar</i>)	EVEN, NONE, ODD			
Number of bit	Fixed 8				
Stop bit number	Configurable (<i>Rserpar</i>)	1	2	bit	
Protocol	Modbus RTU				
ESD protection	Human Body Model	±15		kV	
Number of nodes	256				

RJ45 connector version

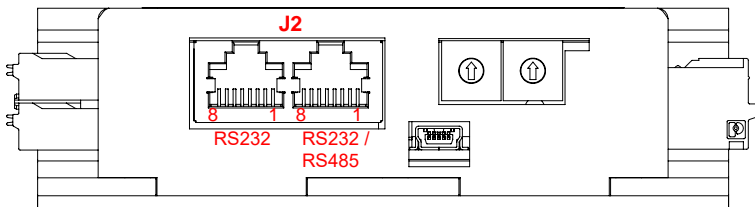

DB9 connector version

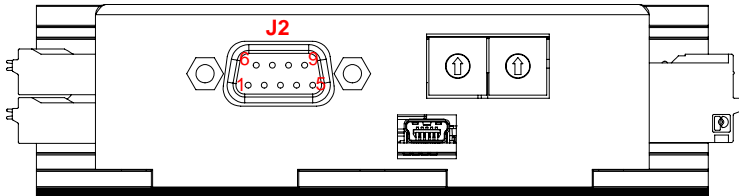

Pin	Signal Name	Description
1	Shield	Shield
2	Data TX	Data RS-232C in trasmission
3	Data RX	Data RS-232C in reception
4	Not Connected	Not connected
5	Comune TX	Communication signals common
6	Not Connected	Not connected
7	Data +	RS-485 Data +
8	Data -	RS-485 Data -
9	Comune TX	Communication signals common



The RS-485 serial interface permits to connect multiple devices in the same communication network, reducing wiring complexity and required resources.

The differential configuration of this type of transmission permirs to improve the immunity to disturbances with respect to a normal RS-232C communication, and consequently to work in severe environments.

To obtain the maximum efficiency from a RS-485 serial network, it is preferable to adopt all the linear topographies (daisy-chain, token-ring) rather than star topographies, because each deviation (stub) may create line reflection or communication problems.

In case of open lines, it is necessary to terminate the free ends of the line with a properly sized terminator.

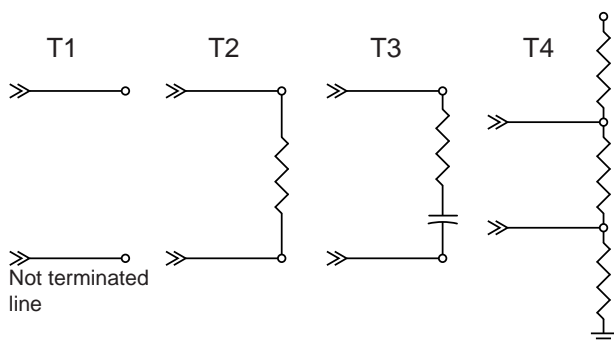

Types of terminators

Terminators characteristics

Reference	T1	T2	T3	T4
Type of thermanation	None	Parallel	RC	Failsafe
Data rate	Low	High	Medium	High
Quality of the signal	Limited	Excellent	Limited	Excellent
Power	Low	High	Low	High

The most used termination method is the parallel terminator, made with a $120 \Omega \frac{1}{2}W$ resistance.

RS-232 connection example

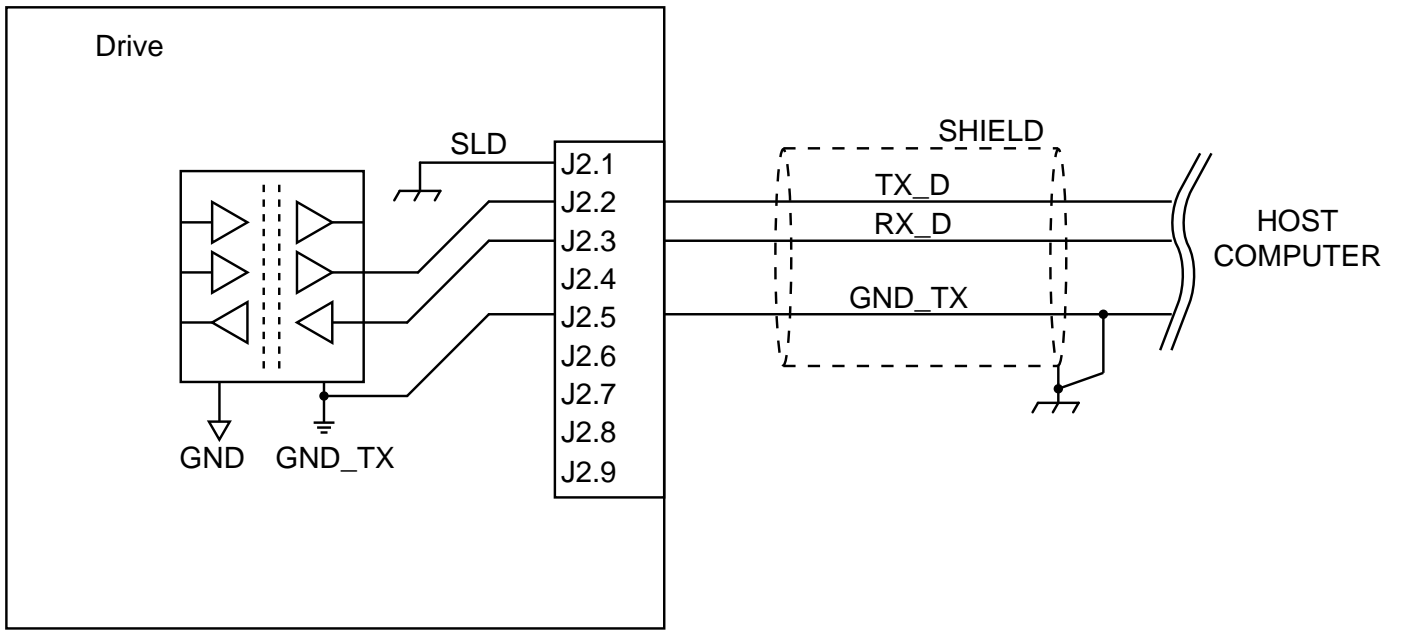

RS-485 connection example

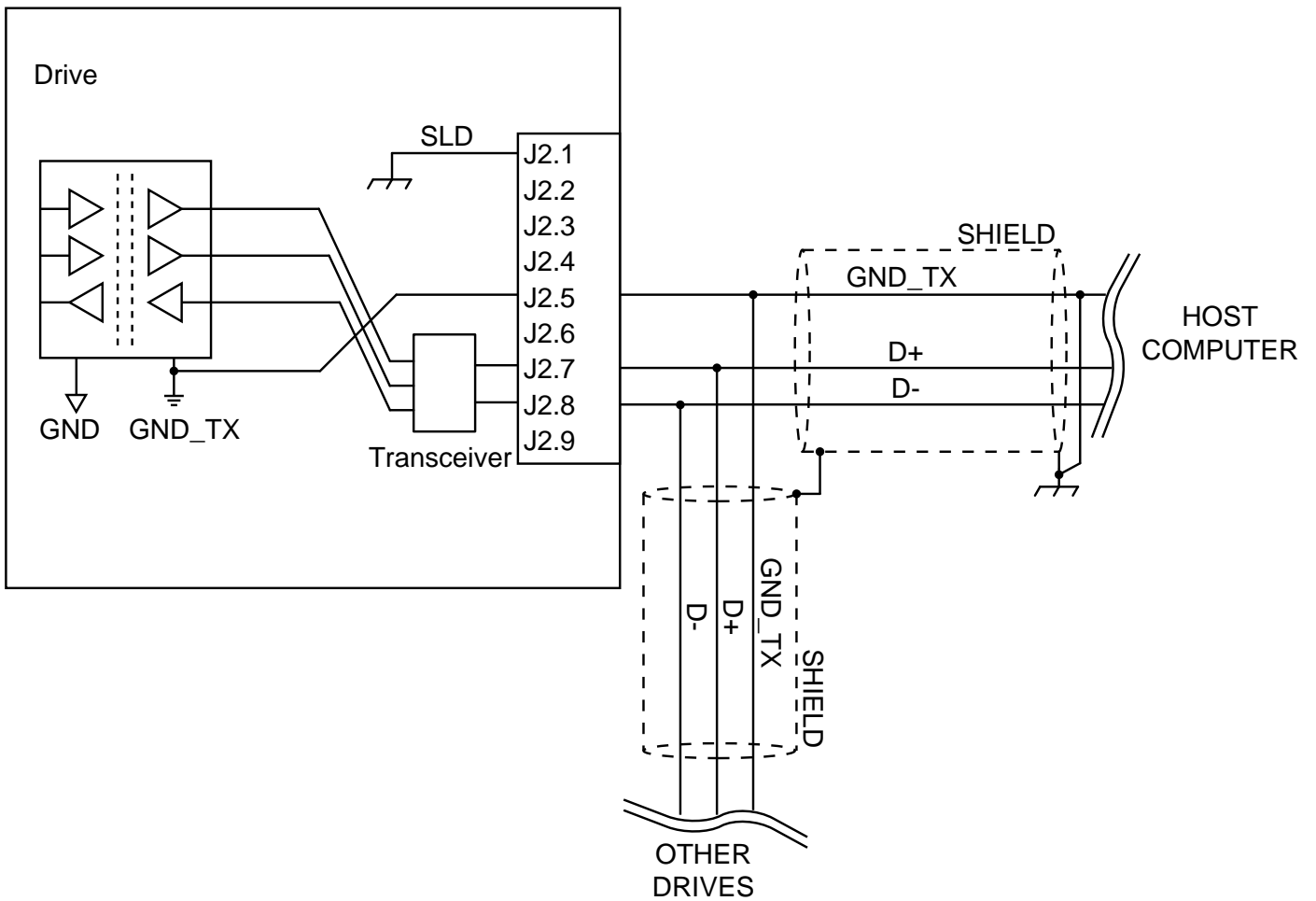

Type	Full CAN V.2.0b physical layer for high-speed connections compliant
Number of channels	1
Insulation	High speed (5Mbps) capacitive digital insulator
Functions	Real-time motion control, configuration and parameterization, programming, diagnostic and remote control

		Min.	Typ.	Max.	Units
Protocol	Motion Control Device according to DSP-402 V.1.1 specifications of the applicative layer of CANopen DS-301 V.4.0 (EN50325-4)				
Supported modes	Profile Velocity Mode, Torque Profile Mode, Homing mode, Profile Position Mode, Interpolated Position Mode				
Signals	CAN_H, CAN_L, CAN_GND				
Baudrate	Configurable (<i>Rcanbaud</i>)	10		1000	KB/s
Addressing	Rotary DIP switches + software address (<i>Rcanaddr</i>)				
Termination	Resistenza esterna da 120Ω				
Error control	Node guarding, Life guarding, Heartbeat				
Number of PDO	Mappable	4 Rx		4 Tx	
PDO Mode	Event Triggered, Sync (cyclic), Sync (acyclic), RTR				
PDO linking	No				
PDO mapping	Variable (granularity 8 bit)				
Number of SDO		1 Server		0 Client	
Emergency messages	Yes				
Framework	No				
Vendor ID	<i>AEC srl</i>	00 00 00 BCh			

Cable characteristics:

Parameter	< 300 m	> 300 m
Type	Lumberg STL253 2 x 0,25 mm ² (twisted pair with shield) 2 x 0,34 mm ² (twisted pair with shield)	Lumberg STL253 2 x 0,82 mm ² (twisted pair with shield) 2 x 1,50 mm ² (twisted pair with shield)
Resistance	≤ 40 Ω/km	≤ 40 Ω/km
Capacity	≤ 130 nF/km	≤ 130 nF/km
Matches	Pair 1 (Black / Red): CAN-GND and +Vs Pair 2 (White / Blu): CAN-HIGH and CAN-LOW	



To obtain a communication network which is immune to noise, respect the recommended maximum lengths and sections, remove possible potential differences between the nodes by connecting all the nodes to earth or by using an additional potential compensation cable.

Maximum permitted lengths for cables and stubs

The length of cables and stubs depends on the working baud-rate of the network.

Baudrate (Kb/s)	10	20	50	100	125	250	500	800	1000
Maximum length of the network (m)	5000	3000	1000	500	400	200	75	30	25
Maximum length of the stubs (m)	1360	875	350	175	140	70	35	20	17
Maximum length of each stub (m)	270	175	70	35	28	14	7	4	3

The maximum length of each single segment depends also on the cable section and on the number of nodes connected to the segment itself.

Number of connected nodes	Cable section		
	0,75 mm ²	0,5 mm ²	0,25 mm ²
x < 32	550	360	200
32 < x < 64	470	310	175
64 < x < 100	410	270	150

Measures are expressed in m.

For bus lengths exceeding 1000 m it is recommendable to insert bridges or repeaters.

SMD1204xIC-DExxx models (DB9 connector)

Pin	Symbol	Signal name	Description
1	-	Reserved	Reserved
2	CAN_L	CAN L line	Dominant CAN line
3	CAN_GND	Common TX	Communication signals common
4	-	Reserved	Reserved
5	CAN_SHLD	CAN Shield	Shield
6	-	Reserved	Reserved
7	CAN_H	CAN H line	Recessive CAN line
8	-	Reserved	Reserved
9	-	Reserved	Reserved

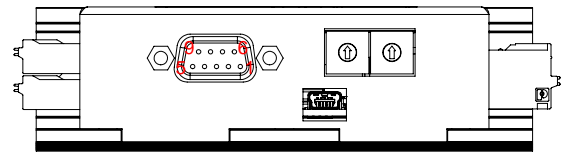

SMD1204xIC-JExxx models (RJ45 connector)

Pin	Symbol	Signal Name	Description
1	CAN_H	CAN H line	Recessive CAN line
2	CAN_L	CAN L line	Dominant CAN line
3	CAN_GND	Common TX	Communication signals common
4	-	Reserved	Reserved
5	-	Reserved	Reserved
6	CAN_SHLD	CAN Shield	Shield
7	CAN_GND	Comune TX	Communication signals common
8	-	Reserved	Reserved

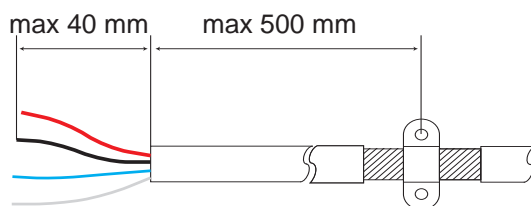
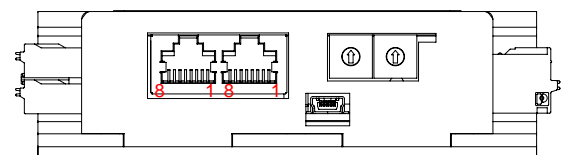

CAN communication networks must ALWAYS terminate with a 120Ω resistance both at the beginning and at the end.

In case of particular topographies, e.g. star networks or divided into more sections, each branch must be terminated.

PROFIBUS INTERFACE (SOLO SMD1204xxP)

	Min.	Typ.	Max.	Units
Type	Profichip controller, RS-485 half-duplex physical layer for high-speed connections compliant			
Number of channels	1			
Insulation	High speed (25Mbps) capacitive digital insulator			
Cable	Twisted pairs (1 twisted pair with shield)			
Functions	Real-time motion control, configuration and parameterization, programming, diagnostic and remote control			
Protocol	PROFIdrive according to Profile Drive Technology version 4.1 specifications, May 2006 (IEC 61800-7)			
Supported modes	Autobirate, Sync Mode, Fail Safe, DP-V0 (Standard Telegram 7,8,9 and PKW Telegram), DP-V1, I&M, Positioning Mode, Telegram configuring, Fault Buffer			
Signals	A, B, +5Vs DP, 0 V DP, Shield			
Baudrate	Autobirate, Configurable (<i>Rprofibaud</i>)	9,6	12000	KB/s
Addressing	Rotary DIP switches + software address (<i>Rprofiaddr</i>)			
Termination	External resisitive (Pull-up 390Ω, Teminat. 220Ω, Pull-down 390Ω)			
Error control	Checksum, DP-V1 Watchdog 1ms			
Supported masters	Class 1, Class 2			
Application Class	3 (Single axis positioning drive, with local motion control)			
Traversing Tasks	64			

The following chart shows the main characteristics for A-category Profibus-DP cables, according to the IEC61158/EN 50170 standard.

Name	Description
Impedance	135 ... 165 Ω a 3 ... 20 MHz
Capacity	< 30 pf / m
Resistance	< 110 Ω / km
Diameter	> 0,64 mm
Section	> 0,34 mm ²



To obtain a communication network which is immune to noise, respect the recommended maximum lengths and sections, remove possible potential differences between the nodes by connecting all the nodes to earth or by using an additional potential compensation cable.

Maximum permitted lengths for cables and stubs

Data Transfer rate in kbit/s	9.6	19.2	45.45	93.75	187.5	500	1500	3000	6000	12000
Max.segment length in m	1200	1200	1200	1200	1000	400	200	100	100	100



In Profibus-DP networks, it is inadvisable to use passive stubs.

In case of connection of diagnostic or programming devices, it is necessary to use active stubs (terminators, repeaters, active cables).

In order to minimize the reflection effects and the line noise, the Profibus-DP network must be terminated at both ends as the following scheme (according to IEC61158/EN 50170 standard for 9-pin SUB-D connectors).

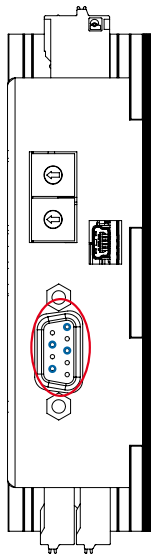

Pin	Symbol	Signal name	Description
1	Shield	Shield	Shield
2	-	Reserved	Reserved
3	B	B Line red	Positive RXD/TXD
4	-	Reserved	Reserved
5	DGND	D_GROUND	Digital mass (for terminator)
6	VP	V_POWER	Power supply 5V (for terminator)
7	-	Reserved	Reserved
8	A	A Line green	Negative RXD/TXD
9	-	Reserved	Reserved

Minimum distance between Profibus cables and other cables	Distance (in mm)		
	Without cable trays or with non metallic cable trays	With aluminium cable trays	With steel cable trays
Signal			
<ul style="list-style-type: none"> Communication networks similar to Profibus Digital signals of low power (sensors, PLC, PC) Shielded analog inputs or outputs 	0	0	0
Power supply			
<ul style="list-style-type: none"> Not shielded 	200	100	50
<ul style="list-style-type: none"> Shielded 	0	0	0

In case it is not possible to keep the minimum distances required, it is necessary to use two separate metallic rails, each one containing cables of the same category. In this case, the two rails can be tiled.



The following table summarizes the specifications of Modbus TCP/IP communication.

Standard	IEC61158 Type 12
Physical level	Ethernet - 100Base-TX
Bus topology	Line Tree
Modulation type	Baseband
Transmission speed	100Mbps
Communication cable	Category 5 or higher (cable with double aluminum tape and braided shielding is recommended.)
Connector	RJ45 (Shielded)
Communication distance	Distance between nodes (slave): 100m max
Noise resistance	Conform to IEC61000-4-4, 2kV criteria A
LED	L/A IN (Link activity IN): 1 L/A OUT (Link activity OUT): 1 ECAT RUN (Green): 1 ECAT ERR (Red): 1

 **Place the motor cable at a distance of at least 300 mm from signal cables (encoder, analogic, fast inputs) or communication cables. Do not lock up or pass the motor cable in the same conduit of signal cables.**

The following table summarizes the specifications of EtherCAT communication.

Standard	IEC61158 Type 12
Physical level	Ethernet - 100Base-TX
Bus topology	Line Tree
Modulation type	Baseband
Transmission speed	100Mbps
Communication cable	Category 5 or higher (cable with double aluminum tape and braided shielding is recommended.)
Connector	RJ45 (Shielded) ECAT IN : EtherCAT Input ECAT OUT: EtherCAT Output
Communication distance	Distance between nodes (slave): 100m max
Noise resistance	Conform to IEC61000-4-4, 2kV criteria A
EtherCAT Device ID	Set physical address at master: 1-65535
Support protocol	CoE (CANOpen application protocol over EtherCAT)
Control profile	CiA DS402 drive profile (IEC61800-7)
Supported operation modes	8 - Cyclic Synchronous Position Mode 6 - Homing Mode 1 - Profile Position Mode -1 - Manufacturer JOG Mode
Distributed clock	Free Run SM event mode DC Mode
Processing Data	8 Configurable PDO Mapping (1600-1607) 8 Configurable PDO Mapping (1A00-1A07) 8 Single object per PDO
Mailbox (CoE)	SDO requests, SDO responses
LED	L/A IN (Link activity IN): 1 L/A OUT (Link activity OUT): 1 ECAT RUN (Green): 1 ECAT ERR (Red): 1

 Place the motor cable at a distance of at least 300 mm from signal cables (encoder, analogic, fast inputs) or communication cables. Do not lock up or pass the motor cable in the same conduit of signal cables.

CONNECTOR

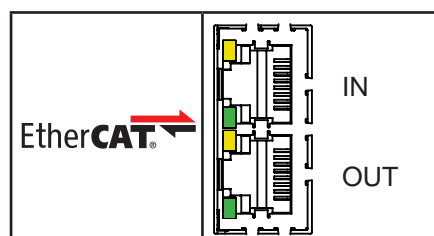



The following table is an overview for the PROFINET features supported by SMDyyyyxIN drives

PROFINET RT	✓
PROFINET IRT (RT_CLASS_3)	✓
Advanced Startup	✓
Legacy Startup	✓
Minimum cycle time, RT	250us (motor controlled every 1ms)
Minimum cycle time, IRT	250us (motor controlled every 1ms)
Enhanced Configuration Support	✓
Support of I&M5	✓
Simple Network Management Protocol (SNMP)	✓
MRP Client (Media Redundancy Protocol)	✓
Number of ARs / Shared Device capable	1
IO Supervisor AR	1 (only device access)
Acyclic communication	Read/Write Record
Alarm Types	Process Alarm, Diagnostic Alarm, Plug Alarm, Pull Alarm, Return of Submodule Alarm
Identification & Maintenance	I&M0-5
Topology recognition	LLDP, SNMP V1, MIB2, PDEV
Media Redundancy	MRP client
Additional supported features	DCP, 802.1q Priority
Data rate / duplex	100 MBit/s, Full Duplex
Data transport layer	Ethernet II, IEEE 802.3
PROFINET IO specification	V2.35

TECHNICAL DATA

Type	Ethernet network
Cable	Ethernet CAT. 5e
Function	Real-time motion control, setup and parameterization, programming, diagnostics
Protocol	PROFIdrive according to Profile Drive Technology version 4.1, May 2006 (IEC 61800-7)
Error checking	Checksum
Supported Masters	Class 1, Class 2
Application Class	3 (Single axis positioning drive, with local motion control)
Number of port	2

RESTRICTIONS

Following restriction apply:

- RT over UDP not supported
- DHCP is not supported
- Fast Startup iso not supported
- Shared Inputs are not supported
- Multicast communication not supported
- Only 1 Input-CR and 1 Output-CR per AR is supported
- System Redundancy (SR-AR) and Configuration-in-Run (CiR) are not supported
- The amount of configured IO-data influences the minimum cycle time that can be reached.

EMC IMMUNITY

To prevent them from being created EMI disturbances caused by cables or devices contained in the same power panel, the drive must be properly connected to protective earth as described in the in the manual.

AEC does not guarantee proper EMC behavior unless the PE requirements are fulfilled



The shield of the RJ45 connector is not connected directly to PE. As all nodes in a Profinet network have to share earth connection, the Profinet cable shield has to be connected to the earth at each node in the network.

For further information, see "PROFINET Installation Guideline for Cabling and Assembly, no. 8072" available to download at www.profinet.com

CONNECTOR PINOUT

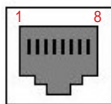

Pin no	Description
1	TD+
2	TD-
3	RD+
4, 5, 7, 8	Connected to ground over serial RC circuit
6	RD-
Housing	Cable Shield

CERTIFICATION

The SMDyyyyxIN device was tested with the official PROFINET IO Test Bundle of PI (Release 2017-04-05) at ComDeC test lab (Würzburger Straße 121, 90766 Fürth, Germany).

STAND-ALONE CONTROL

The VectorStep drives can be controlled in different modes:

- Stand-alone
- Dirwct with Modbus RTU, CANopen ,Profibus DP, Modbus TCP, EtherCAT or Profinet
- Mixed
- Through inputs

This makes the devices very flexible and suitable for a high number of different applications.

The control modes are simultaneously active inside the drive, allowing a continuous interaction between them..

GENERAL CHARACTERISTICS

SMD1204xlx units are “intelligent” and programmable drives, able to execute complete small automations without being connected to further control devices as a PC or a PLC.

Exploiting the flexibility of the axis control, it is possible to realize complex movement and logic sequences, electronic cams, positionings in absolute or relative quota, to manage of digital and analog inputs, to drive external devices through digital or analog outputs, to interface with visualization devices such as HMI.

The SMD1204xlx is able to manage interrupt events and to monitor inputs and outputs, also during a positioning.

ARCHITECTURE

The control chain of the VectorStep drives is composed in levels, in order to guarantee the maximum efficiency and safety in the management of movements and control signals of the motor.

The “thinking head” of the system is the motion controller, which has the task to collect the commands and the information from the “external world” and to elaborate and convert them in signals to be sent to the power stage.

The information elaborated by the motion controller may result from multiple channels:

- digital and/or analog inputs/outputs interface;
- user program;
- fieldbus interface;

The commands sent from the user program or from the fieldbus, before being sent to the motion controller, are translated (interpreted) from the interpreter so that to standardize the requests.

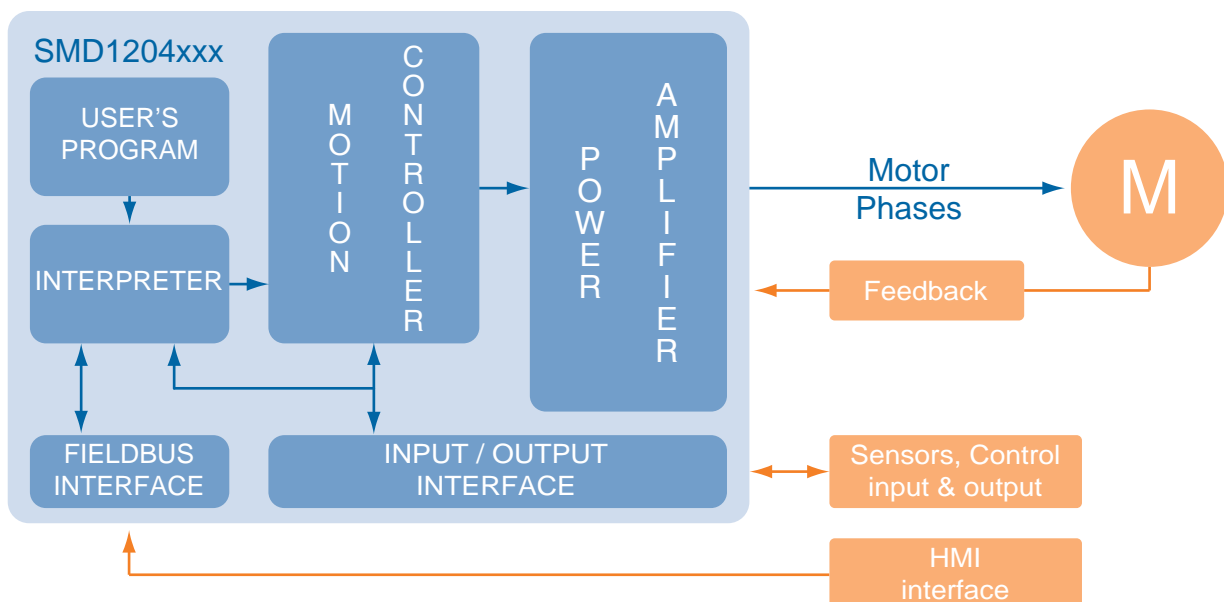

SUPPORTED FUNCTIONS

The SMD1204xix is equipped with a programmable axis control, which supports multiple function modes, listed below:

Function	Description
Autorun	Define which operations must be automatically executed by the drive at start-up. Permit to load the parameters and to start automatically the execution of the program at the start-up of the drive, to enable the management of the hardware and software limits and to set the default movement parameters.
Positioning	Permit to execute positionings in absolute or relative quota with specific parameters. The movement commands can be queued or over-imposed in order to change the target "on the fly". The over-imposed movement commands also permit to change the acceleration and deceleration parameters during the movement.
Jog	Permit to execute movement in velocity without target quota. It is possible to update the speed and acceleration/deceleration parameters without stopping the motor.
Stop	Permit to stop the motor in ramp or in emergency ramp. The STOP can be given with a direct command (fieldbus or user program), received from digital inputs or generated by an event (defined via program).
Homing	Permit to synchronize the linear or rotative axis on a zero point by using automatic search sequences.
Electronic cam	Permit to execute movement profiles, more or less complex, in synchronism with a master encoder.
Setup	Permit to modify the current levels, the step resolution and to enable or disable the drive during the execution of the user program.
Interrupt	Permit to manage in asynchronous way the inputs, the limits, and events such as alarms, warnings or custom events, also during a positioning. The interrupt management can be activated on the rising edge, on the falling edge or on both edges. VectorStep drives can manage up to 10 interrupts simultaneously.
Inputs management	Permit to verify the state of the digital or service (BLS, FLS) inputs of the drive. It is also possible to interrupt the execution of the program, waiting an input or a input sequence, as well as to verify the state of the registers memory latch. At each digital input, it is possible to pre-assign some specific functions such as "go to quota", "axis homing", "move forward", "alarms reset", "enable drive" ecc.
Outputs management	Permit to set, reset, invert or test the state of the digital outputs of the drive. As for the inputs, it is possible to pre-assign some specific functions such as "drive in alarm", "drive in movement" ecc.
Calculations	Permit to perform mathematical or logical operations on internal data, registers and variables.
Tests and jumps	Permit to verify events or conditions (both value and bit) and change the working flux in relation to the tests results.
Timer	Permit to insert delays or time-out cycles to synchronize movements or logical sequences.
Save	Permit to save the internal variables in the NVRAM to keep the data also with the drive switched off.
User program	It is a instructions sequence which permits the drive to perform any logical, movement or mixed sequence. It can be written directly by the final user, choosing between two programming methods: visual (simpler and more intuitive) or text-based (more complex, but more powerful and flexible).
Task manager	The SMD1204xix support 64 movement sequences which can be programmed and recalled via inputs, user program or fieldbus. Each task is a group of parameters which defines a movement: target position, velocity, acceleration, deceleration, relative or absolute positioning, pre or post execution delay. It is also possible to concatenate two or more tasks in order to generate a sequence of movements.

PROGRAMMING METHODS

The drives SMD1204xxx support three programming methods:

- Task
- Visual
- Text-based

TASK PROGRAMMING

It is the simplest but more limited method; it can be described as a parameters table which defines one or more movements.

The table is composed by 64 movement sequences, callable via inputs, fieldbus or user program.

Each sequence groups the following parameters:

Register	Name	Description																													
Ttargpos	Target position	Required target position expressed in steps (open-loop) or encoder pulses (closed-loop)																													
Ttargvel	Target velocity	Required target velocity expressed in hundredths of a rev per second (rps x100)																													
Ttargacc	Acceleration	Acceleration expressed in tenths of a rev per second square (rps ² x10)																													
Ttargdec	Deceleration	Deceleration expressed in tenths of a rev per second square (rps ² x10)																													
Ttimer	Delay	Task re or post-execution delay expressed in milliseconds (ms)																													
Tmode	Mode	Tak functioning paramters:																													
		<table border="1"> <thead> <tr> <th>Bit</th> <th>Status</th> <th>Description</th> </tr> </thead> <tbody> <tr> <td rowspan="2">0</td> <td>0</td> <td>Absolute target quota</td> </tr> <tr> <td>1</td> <td>Relative target quota</td> </tr> <tr> <td>[1..11]</td> <td>x</td> <td>Reserved</td> </tr> <tr> <td rowspan="2">12</td> <td>0</td> <td>Disable concatenation</td> </tr> <tr> <td>1</td> <td>Enable concatenation</td> </tr> <tr> <td>13</td> <td>0</td> <td>Task (always 0)</td> </tr> <tr> <td rowspan="2">14</td> <td>0</td> <td>Wait Ttimer before executing the task</td> </tr> <tr> <td>1</td> <td>Wait Ttimer after the execution the task</td> </tr> <tr> <td rowspan="2">15</td> <td>0</td> <td>Disabled task (invalid data)</td> </tr> <tr> <td>1</td> <td>Enabled task (valid data)</td> </tr> </tbody> </table>	Bit	Status	Description	0	0	Absolute target quota	1	Relative target quota	[1..11]	x	Reserved	12	0	Disable concatenation	1	Enable concatenation	13	0	Task (always 0)	14	0	Wait Ttimer before executing the task	1	Wait Ttimer after the execution the task	15	0	Disabled task (invalid data)	1	Enabled task (valid data)
		Bit	Status	Description																											
		0	0	Absolute target quota																											
			1	Relative target quota																											
		[1..11]	x	Reserved																											
		12	0	Disable concatenation																											
			1	Enable concatenation																											
		13	0	Task (always 0)																											
		14	0	Wait Ttimer before executing the task																											
1	Wait Ttimer after the execution the task																														
15	0	Disabled task (invalid data)																													
	1	Enabled task (valid data)																													
Tnexttask	Next task	Number of the next task to be executed (if concatenation is enabled)																													

 If a task is launched with a sequence in progress, the execution of the sequence is interrupted.

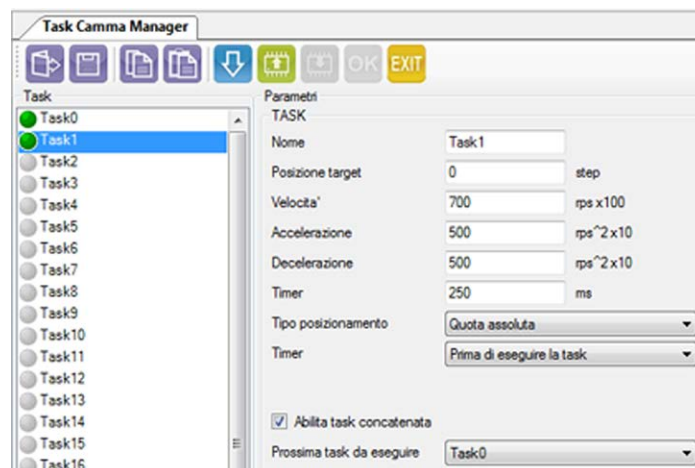















VISUAL PROGRAMMING

Unlike the task method, besides movement sequences, the visual programming allows to realize logical sequences, conditioned by inputs and outputs.

Thanks to the intuitive graphical interface, it becomes easy to create structured programs, which permit to manage not only the movement of the motor, but also limit switches, buttons, digital and/or analog sensors, electrovalves etc.

The visual programming provides to the user a series of macro-commands, where is sufficient to insert the requested parameters to generate a command to be sent to the drive.

Command	Description
	Positioning commands. GO (go to absolute quota), GOR (go to relative quota), JOG (move forward or backward without target quota). For each movement it is possible to define velocity, acceleration and deceleration parameters.
	Homing commands. Define the type of homing to be performed and the zero point search parameters
	Stop commands. Stop the movement or the task in progress, in ramp or in emergency ramp. It is possible to indicate if the stop must be executed immediately or condition it to the occurrence of an event.
	Gearing commands. Enable and configure the management of an electronic cam.
	Setup commands. Enable or disable the drive, set the current level, the step resolution of the motor, and define the automatic current reduction parameters.
	Interrupt commands. Enable the interrupt management on the rising or falling edge of inputs or events, manages the return from an interrupt routine and the re-enabling of the same.
	Data management. Permit to copy or shift data between variables and/or registers, reset or invert the state of the bit of any parameter, or define the pointer variables.
	Calculation commands. Permit to perform mathematical operations (additions, subtractions, multiplications and divisions) or logical (AND, OR, XOR, NOT) between different types of data (variables, registers, direct values).
	Input commands. Test or wait the state of digital and service inputs (limit switches, encoder etc.) of the drive. In addition, permit to verify the state of inputs memory registers.
	Output commands. Set, reset, invert or test the state of a digital output.
	Test commands. Compare two values (variables, register or direct values), or verify the state of the bit of the indicated parameter.
	Jump commands. Inserted after a test instruction, permit to modify the execution flow of the user program basing on the test result. Also permit to call sub-routines or return from sub-routines.
	Timer commands. Stop the execution of the program for the indicated time.
	Save commands. Save in the NVRAM the indicated variable.
	Custom commands. Permit to write in Text-based mode a customized command, in case of particular needs.

TEXT-BASED PROGRAMMING

Text-base mode is a low-level programming method, which permits to exploit the 100% of the VectorStep drives functionalities.

The programming system is based on MIL language (Mnemonic Indexer Language), developed by AEC thanks to the experience in motion control and stepper motors management.

The instructions set includes commands for data management, calculations, save and test.

Family	Command	Description
Positioning	GO	Absolute quota positioning.
	GOR	Relative quota positioning.
	JOG	Move forward or backward without target quota.
Homing	HOME	Axis homing
Stop	STOP	Stop the movement in ramp
	ABORT	Stop the movement in emergency ramp
	ESTOP	Stop the movement on event (value)
	BESTOP	Stop the movement on event (bit)
Gearing	CAM	Enable electronic cam
Setup	CUR_ON	Enable drive
	CUR_FULL	Set the nominal current level
	CUR_RED	Set the reduced current level
	BOOST	Set the boost current level
	CUR_OFF	Disable drive
Interrupt	ONH	Enable interrupt management on the rising edge
	ONL	Enable interrupt management on the falling edge
	RTE	Return to program from the interrupt
Data management	MOVE	Shift or copy the value of the variable or register, or assign a direct data
	BSET	Set bit
	BRES	Reset bit
	BCHG	Invert bit
	RIND	Index pointer variable
Calculation	ADD	Add two values (register, variable, direct data)
	SUB	Subtract two values (register, variable, direct data)
	MUL	Multiplies two values (register, variable, direct data)
	DIV	Divide two values (register, variable, direct data)
	AND	Logical AND between two values (register, variable, direct data)
	OR	Logical OR between two values (register, variable, direct data)
	XOR	Logical XOR between two values (register, variable, direct data)
	NOT	Logical NOT of a variable (register, variable)
	INC	Increase variable or register
DEC	Decrease variable or register	
Inputs management	BTEST	Test the value of a bit
	BWAIT	Stop the program until the value of a bit meets the condition
Outputs management	BTEST	Test the value of a bit
	BSET	Set bit
	BRES	Reset bit
	BCHG	Invert bit
Test	TEST	Compare two values (register, variable, direct data)
	BTEST	Test the value of a bit

Family	Command	Description
Jump	JMP	Conditioned or unconditioned jump to a program label
	JSR	Conditioned or unconditioned call to a subroutine
	RTS	Return to program from a sub-routine
Timer	TIMER	Stop the execution of a program for the indicated time
Save	VSAVE	Save in NVRAM the indicated variable

Tipo azionamento SMD50.06HIM

Rem	Label	Icona	Commento fisso	Commento utente
01			Abilita corrente nominale	Imposta corrente nominale
02			Abilita l'uscita di corrente al motore	Abilita corrente
03	INIZIO		Abilita gestione interrupt evento LOW	Abilita gestione interrupt su ingresso 8
04			Spegni uscita 1	Disattiva OUT fine ciclo
05			Spegni uscita 2	Disattiva OUT scarto
06			Attendi ingresso 9 allo stato NE	Attendi ingresso START ciclo
07			Testa ingresso 10	Testa ingresso rottore
08			Salta a EE se valida la condizione E	Se ingresso basso
09	REG		Muovi motore in direzione +	Imposta parametri e muovi avanti (Avvita)
10			Attendi ingresso 10 allo stato E	Attendi ingresso basso
11			Ferma motore in rampa	Ferma rotazione motore
12			Muovi motore in direzione -	Muovi indietro
13			Attendi ingresso 10 allo stato NE	Attendi ingresso alto
14			Ferma motore in rampa	Ferma rotazione motore
15			Sposta di V4 passi	Vai alla posizione relativa indicata in V4
16	FINE		Attiva l'uscita 1	Attiva OUT fine ciclo
17			Attendi ingresso 9 allo stato E	Attendi ingresso FINE ciclo
18			Salta a INIZIO se valida la condizione A	Toma ad inizio programma
19	FERMA		Ferma motore con rampa di emergenza	Ferma rotazione

ToolBox

START-UP CONFIGURATION

One of the main issues of stand-alone devices is to define their behaviour at start-up, determine if the user program must be run automatically at the start-up, load the minimum needed parameters to let the drive work without parameterizing it via PC, and define the enabling status of the drive at start-up.

The configuration of these last parameters (enabling and configuration) could be superfluous in case the drive contains a user program, but they are fundamental in case of task programming and macro-functions associated to inputs.

In this last case, in fact, movement and homing parameters, and the associated functions, would result not initialized, and the drive would not perform any command.

The SMD1204 integrates a set of registers which contains the start-up settings to let the drive auto-configure at the start-up.

Below are the registers:

Registro	Name	Description	
Rstrtconf	Configuration at start-up	Define the configuration mode at start-up	
		Value	Description
		0x00	Nessuna configurazione
		0x01	Riservato
		0x02	Stepper-mode speed (open-loop)
		0x03	Stepper-mode position (open-loop)
		0x04	Stepper-mode Step/Dir (open-loop)
		0x05	Servo-mode torque (closed-loop)
		0x06	Servo-mode speed (closed-loop)
		0x07	Servo-mode position (closed-loop)
0x08	Servo-mode Step/Dir (closed-loop)		
Rstrtmode	Operation mode at start-up	Operations to be executed at start-up	
		Value	Description
		0x00	Load the registers from NVRAM
		0x01	Load the registers and set the operation mode
		0x02	Load the registers, set the operation mode and enable the drive
0x03	Load the registers, set the operation mode, enable the drive and run the program		
Rstrpostarg	Default target position	Set the target position at start-up (pulse)	
Rsrvel	Default translation speed	Set the translation speed at start-up (rps x100)	
Rstrvss	Default start/stop speed	Set the start/stop speed at start-up (rps x100)	
Rstrtacc	Default acceleration	Set the default acceleration ramp (rps ² x10)	
Rstrtdec	Default deceleration	Set the default deceleration ramp (rps ² x10)	
Rstrthmode	Default homing mode	Set the homing mode at start-up	
		Value	Description
		0	No homing function requested
		-1	Homing only with BLS in negative direction
		-2	Homing only with BLS in positive direction
		-3	Homing with BLS + TOP rising edge, negative direction
		-4	Homing with BLS + TOP rising edge, positive direction
		-5	Homing only with TOP in negative direction
		-6	Homing only with TOP in positive direction
		-7	Homing with backward mechanical limit + axis measure
		-8	Homing with forward mechanical limit + axis measure
		-9	Homing with backward mechanical limit
-10	Homing with forward mechanical limit		
Rstrthvh	Speed during limit switch search	Set the homing speed during the limit switch search (rps x100)	
Rhvl	Speed during 0 point search	Set the homing speed during the 0 point search (rps x100)	
Rstrthacc	Acceleration during homing	Set the acceleration/deceleration ramp during homing (rps ² x10)	

DIRECT CONTROL

GENERAL CHARACTERISTICS

Unlike the stand-alone control, a drive controlled directly doesn't execute any operation on its own initiative (no resident program), but waits for commands from a Host computer, a PLC, a PC, or via fieldbus.

All the drives support at least one fieldbus: Modbus RTU (SMD1204xIM), CANopen (SMD1204xIC), Profibus DP (SMD1204xIP), Modbus TCP/IP(SMD1204xIE), EtherCAT (SMD1204xIT) and Profinet (SMD1204xIN).

With StepControl, it is possible to monitor the state of the drive and the internal parameters, also when the drive is communicating with a network.

With the available fieldbus it is possible to access to all the resources of the device:

- Drive parameters;
- Motor parameters;
- Encoder parameters;
- Movement management Controlword or advanced functions;
- Communication parameters;
- Start-up parameters;
- Registers;
- Variables;
- Tasks management;
- NVRam management.

With this type of control it is possible to avoid the parameterization via StepControl, by sending the configuration data via communication bus.

ARCHITECTURE

The control chain of the VectorStep drives is composed in levels, in order to guarantee the maximum efficiency and safety in the management of movements and control signals of the motor.

The “thinking head” of the system is the motion controller, which has the task to collect the commands and the information from the “external world” and to elaborate and convert them in signals to be sent to the power stage.

The information elaborated by the motion controller may result from multiple channels:

- digital and/or analog inputs/outputs interface;
- fieldbus interface;

The commands sent from the user program or from the fieldbus, before being sent to the motion controller, are translated (interpreted) from the interpreter so that to standardize the requests.

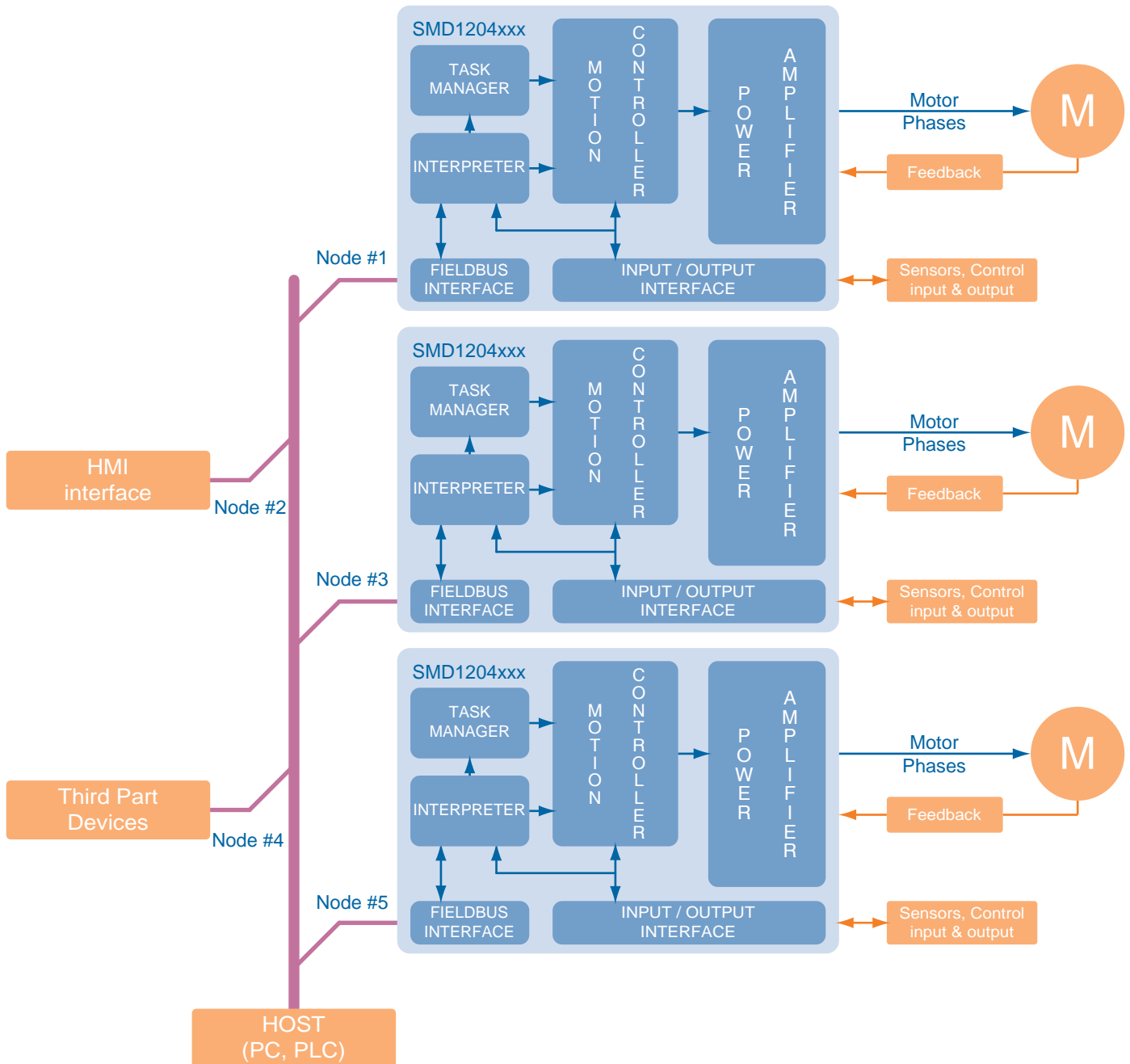

CONTROL WITH MODBUS RTU

Modbus is a serial communication protocol created by Modicon in 1979, in order to put into communication their PLC. It in fact became an industrial standard since 1979, MODBUS permits million automation devices to communicate between each other, by using a request/response type communication, and services defined by function codes. The main reasons for such a wide utilisation of Modbus compared to other protocols are the following:

- 1. It's a royalty-free and openly published protocol
- 2. It can be implemented in few days
- 3. It moves raw bits and words without putting many restrictions

GENERAL CHARACTERISTICS

The drives SMD1204xxx can receive commands or parameters via a serial communication RS-232C or RS-485.

RS-232C and RS485 define the connection standards, the signal levels and the physical characteristics of the final communication channel.

The communication protocol (Modbus RTU) defines the syntax and the codification of the data sent through the physical channel.

The Modbus RTU is a hexadecimal compact data representation, to which a cyclic redundancy check (CRC) checksum field is queued.

The Modbus RTU is a binary communication method in which all the 256 values of a byte carry information. The start and the end of the frame occur by detecting pause times between a frame and another and between a character and another.

If it's detected a pause of 3.5 times the transmission time of a character in the serial line, it means that the frame is ended, and it is possible to proceed with its analysis.

The response of the slave takes place after a minimum pause of 3.5 characters between the frame received and the one to be transmitted.

If it's detected a pause of 1.5 characters between a character and another, instead, the current message is discarded and the device starts receiving a new message.

In this way, all the data can be transmitted without any conversion, maintaining a limited number of bytes for each frame, with the advantage to obtain a quicker communication.

The Modbus RTU protocol doesn't indicate a specific function profile for motion control, but only the standardization of communication commands.

SUPPORTED FUNCTIONS

The Modbus RTU functions code supported by the VectorStep drives are:

Function Code	Name	Description
0x03	Read Holding Register	Read 'n' contiguous Modbus registers (1 register = 16bit)
0x06	Preset Single Register	Write a single Modbus register (16 bit)
0x08	Diagnostic	Provide information on the communication status
0x10	Preset Multiple Register	Write 'n' contiguous Modbus registers

Using that functions and writing in the internal registers, it is possible to modify parameters, read the state of the inputs and outputs, activate outputs, monitor other active communications (CANopen, Profibus DP, EtherCAT) if present and command movements.

ARCHITECTURE

The control chain of the VectorStep drives is composed in levels, in order to guarantee the maximum efficiency and safety in the management of movements and control signals of the motor.

The “thinking head” of the system is the motion controller, which has the task to collect the commands and the information from the “external world” and to elaborate and convert them in signals to be sent to the power stage.

The information elaborated by the motion controller may result from multiple channels:

- digital and/or analog inputs/outputs interface;
- fieldbus interface;

The commands sent via Modbus RTU, before being sent to the motion controller, are translated (interpreted) from the interpreter so that to standardize the requests.

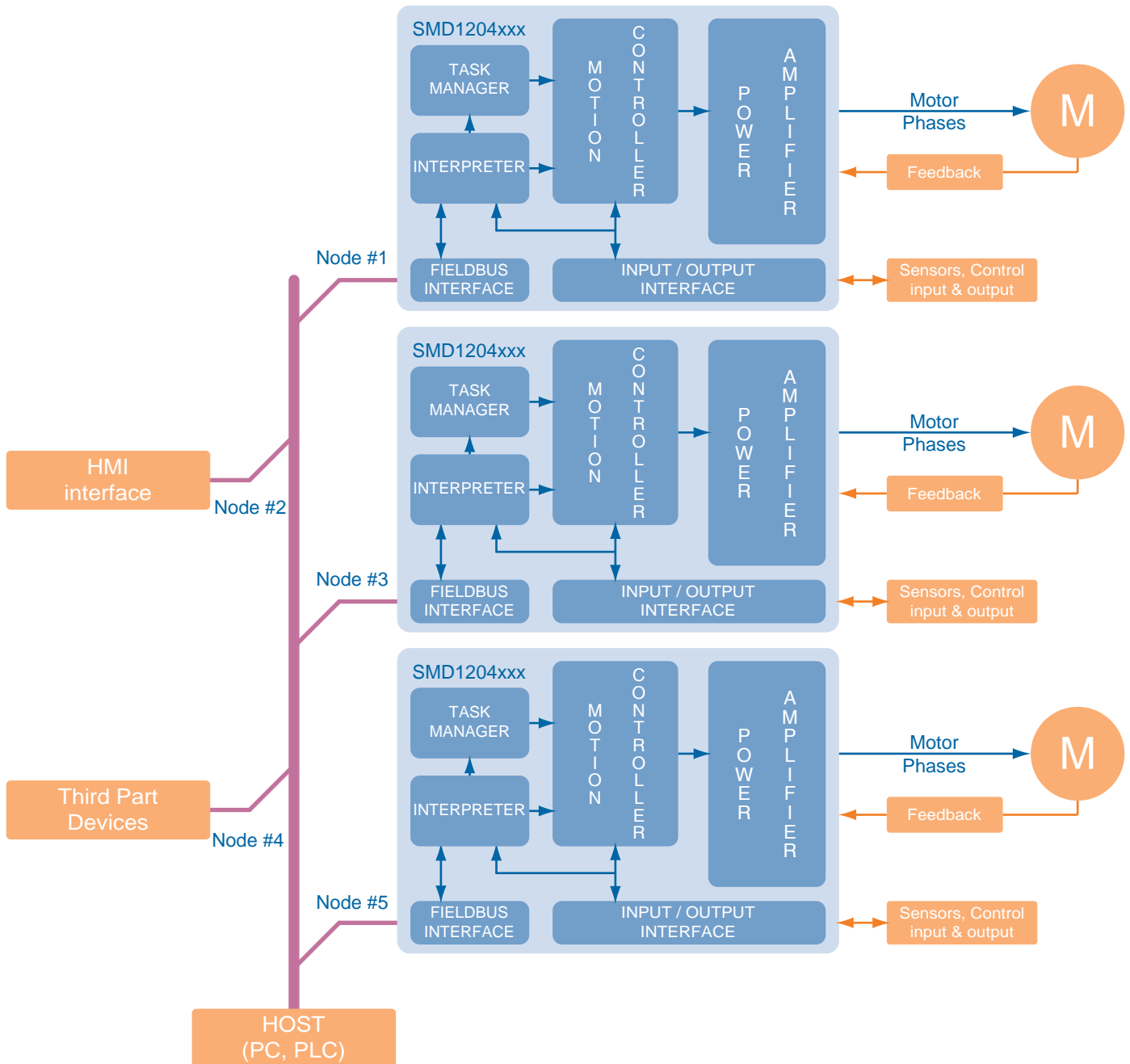

COMMUNICATION SPEED

The SMD1204xxx is able to communicate with a baudrate between 1200 and 115200 bps.

In addition to the communication speed it is possible to configure the number of stop bits, the parity and the type of access to multiple registers.

Register	Nome	Description																							
Rserbaud	Serial Baudrate	Set the serial communication speed: <table border="1"> <thead> <tr> <th>Value</th> <th>Description</th> </tr> </thead> <tbody> <tr> <td>0x00</td> <td>1200 bps</td> </tr> <tr> <td>0x01</td> <td>2400 bps</td> </tr> <tr> <td>0x02</td> <td>4800 bps</td> </tr> <tr> <td>0x03</td> <td>9600 bps</td> </tr> <tr> <td>0x04</td> <td>19200 bps</td> </tr> <tr> <td>0x05</td> <td>38400 bps</td> </tr> <tr> <td>0x06</td> <td>57600 bps</td> </tr> <tr> <td>0x07</td> <td>115200 bps</td> </tr> </tbody> </table>	Value	Description	0x00	1200 bps	0x01	2400 bps	0x02	4800 bps	0x03	9600 bps	0x04	19200 bps	0x05	38400 bps	0x06	57600 bps	0x07	115200 bps					
Value	Description																								
0x00	1200 bps																								
0x01	2400 bps																								
0x02	4800 bps																								
0x03	9600 bps																								
0x04	19200 bps																								
0x05	38400 bps																								
0x06	57600 bps																								
0x07	115200 bps																								
Rserpar	Serial parameters	Set the communication parameters (parity and bit stop number): <table border="1"> <thead> <tr> <th rowspan="2">Value</th> <th colspan="2">Description</th> </tr> <tr> <th>Parity</th> <th>Stop bit</th> </tr> </thead> <tbody> <tr> <td>0x00</td> <td>None</td> <td>1</td> </tr> <tr> <td>0x01</td> <td>Even</td> <td>1</td> </tr> <tr> <td>0x02</td> <td>Odd</td> <td>1</td> </tr> <tr> <td>0x03</td> <td>None</td> <td>2</td> </tr> <tr> <td>0x04</td> <td>Even</td> <td>2</td> </tr> <tr> <td>0x05</td> <td>Odd</td> <td>2</td> </tr> </tbody> </table>	Value	Description		Parity	Stop bit	0x00	None	1	0x01	Even	1	0x02	Odd	1	0x03	None	2	0x04	Even	2	0x05	Odd	2
Value	Description																								
	Parity	Stop bit																							
0x00	None	1																							
0x01	Even	1																							
0x02	Odd	1																							
0x03	None	2																							
0x04	Even	2																							
0x05	Odd	2																							
Rserdly	Serial reply delay	Set the drive response delay to a request in ms. (Used when communicating with autpco-switch converters)																							
Rintmot	Multiple access data format	Define the access method to multiple registers (32bit) via Modbus: <table border="1"> <thead> <tr> <th>Value</th> <th>Description</th> </tr> </thead> <tbody> <tr> <td>0x00</td> <td> Little Endian (INTEL) When accessing a 32 bit data (2 holding registers) the least significant bit (LSB) is transferred before the most significant bit (MSB). Host → <table border="1" style="display: inline-table; vertical-align: middle;"><tr><td>LSB</td><td>MSB</td></tr></table> → SMD1204xx </td> </tr> <tr> <td>0x01</td> <td> Big Endian (MOTOROLA) When accessing a 32 bit data (2 holding registers) the most significant bit (MSB) is transferred before the least significant bit (LSB). Host → <table border="1" style="display: inline-table; vertical-align: middle;"><tr><td>MSB</td><td>LSB</td></tr></table> → SMD1204xx </td> </tr> </tbody> </table>	Value	Description	0x00	Little Endian (INTEL) When accessing a 32 bit data (2 holding registers) the least significant bit (LSB) is transferred before the most significant bit (MSB). Host → <table border="1" style="display: inline-table; vertical-align: middle;"><tr><td>LSB</td><td>MSB</td></tr></table> → SMD1204xx	LSB	MSB	0x01	Big Endian (MOTOROLA) When accessing a 32 bit data (2 holding registers) the most significant bit (MSB) is transferred before the least significant bit (LSB). Host → <table border="1" style="display: inline-table; vertical-align: middle;"><tr><td>MSB</td><td>LSB</td></tr></table> → SMD1204xx	MSB	LSB													
Value	Description																								
0x00	Little Endian (INTEL) When accessing a 32 bit data (2 holding registers) the least significant bit (LSB) is transferred before the most significant bit (MSB). Host → <table border="1" style="display: inline-table; vertical-align: middle;"><tr><td>LSB</td><td>MSB</td></tr></table> → SMD1204xx	LSB	MSB																						
LSB	MSB																								
0x01	Big Endian (MOTOROLA) When accessing a 32 bit data (2 holding registers) the most significant bit (MSB) is transferred before the least significant bit (LSB). Host → <table border="1" style="display: inline-table; vertical-align: middle;"><tr><td>MSB</td><td>LSB</td></tr></table> → SMD1204xx	MSB	LSB																						
MSB	LSB																								

ADDRESSING

A RS-485 Modbus RTU network normally supports up to 32 nodes (in case of standard transceiver), and up to 128 nodes if low consumption interfaces are used.

The VectorStep drives use a low consumption RS-485 transceiver, so, in case the master supports it, they can be inserted into networks with a high number of nodes.

In a RS-485 network, each node must have a unique address which identifies it.

The address is set through the rotary switches of the drive and, in case of a high number of nodes (higher than 80), from the register Rseraddr.

Some combinations of the rotary switches are reserved and cannot be used as addresses.

Rotary switches		Rseraddr	Address value	Description
x10	x1			
0	0	xx	125	Set the address 125 and load the default communication parameters
[1..8]	[0..9]	0	[1..80]	Set the address in a range between 1 and 80
[1..8]	[0..9]	A	[1..80] + A	Set the address in a range between 1 and 128, by adding the hardware address (rotary switches) and a software offset A (Rseraddr) (e.g.: Rotary = 12 and Rseraddr = 90 → Address = 102)
9	[0..9]	xx	Reserved	Reserved combinations

CONTROL WITH CANOPEN

CAN (Controller Area Network) fieldbus had been originally developed for the automotive market, with the aim of reducing the complexity of the connections needed to put into communication the various electronic devices present in a normal car (ABS, Airbag, SRS etc).

Thanks to its characteristics, like easy wiring and reliability, it was increasingly used in the industrial sector to control complex machineries with distributed intelligence.

Besides the DS301, the devices defined as CANopen compatible must have a further particularization, depending on the segment of devices to which they belong, in order to conform the front-end of the communication on the fieldbus side.

GENERAL CHARACTERISTICS

The drives SMD1204xIC can receive commands and parameters via CAN bus communication network.

CAN bus defines the connections standards, the signals levels and the physical characteristics of the communication channel.

The communication protocol (CANopen) defines the syntax and the coding of the data sent via physical channel.

With the purposes to standardize the interfacement mode between the various devices, and to make simple the use of CAN fieldbus to the user, an organization named Cia has been established. The Cia (Can in automation, website www.can-cia.de) is responsible for the definition of the communication standards. Among several standards, the standard communication protocol named CANopen has been defined. This standard is explained in the Draft Standard DS301 for what it concerns the part common to all the devices that belong to CANopen world.

Besides the DS301, the devices defined as CANopen compatible must have a further particularization, depending on the segment of devices to which they belong, in order to conform the front-end of the communication on the fieldbus side.

These specializations are called "Device Profile", and they are defined in the DS4xx drafts.

As an example, DS401 for I/O modules, DS402 for motion control devices (drives), etc.

Moreover, a CANopen compatible device must comply with the defined type of connectors and their pinouts.

All this gives a significant advantage to the end user, that can switch between a type of drive to another, being sure that nothing will change for what concerns the CAN communication.

SUPPORTED FUNCTIONS

NMT	Slave
Error Control	Node Guarding, Life Guarding, Heartbeat
Node ID	Hardware/Software
Nr. of PDOs	4 Rx - 4 Tx
PDO modes	Event triggered, Sync (cyclic), Sync (acyclic)
PDO linking	No
PDO mapping	Variable (granularity 8bit)
Nr. of SDOs	1 Server, 0 Client
Emergency Message	Yes
CANopen Version	DS301 V4.01
Framework	No
Device Profile	DSP-402 V1.1
AEC's Vendor ID	00 00 00 BC

SUPPORTED OPERATION MODES

The VectorStep drives support the following operation modes:

Value	Type	Description
-1	AEC_Velocity	Permit to move the axis in velocity (JOG) by setting direction, velocity and acceleration and deceleration ramps.
1	Profile Position mode	Permit to perform positionings in absolute or relative quota, by setting direction, velocity, acceleration/deceleration ramps and target quota.
6	Homing mode	Used for the search of the zero point of the axis.
7	Interpolated mode	Permit to perform interpolated movements.

ARCHITECTURE

The control chain of the VectorStep drives is composed in levels, in order to guarantee the maximum efficiency and safety in the management of movements and control signals of the motor.

The “thinking head” of the system is the motion controller, which has the task to collect the commands and the information from the “external world” and to elaborate and convert them in signals to be sent to the power stage.

The commands sent from the CANopen network, before being sent to the motion controller, are translated (interpreted) from the interpreter so that to standardize the requests.

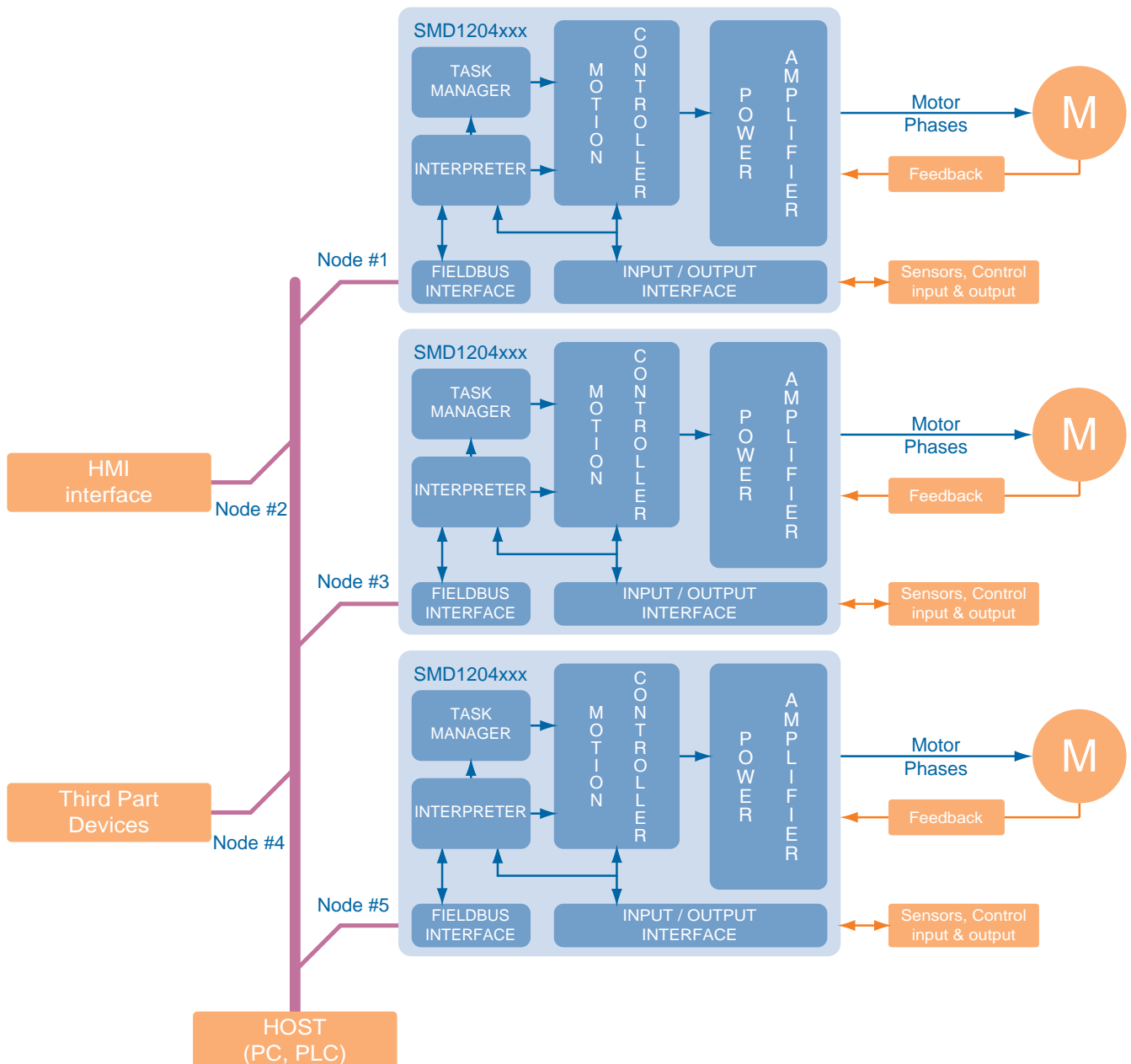

COMMUNICATION SPEED

The SMD1204xIC is able to communicate with a baudrate between 10Kbps and 1000 Kbps.

ADDRESSING

A CANopen network can support up to 127 nodes; each node must have a unique and valid address in the range 1-127 (Node ID). The address 0 is reserved for the broadcast messages.

The node address can be assigned in two ways:

Type	Range	Description
Hardware	[1 .. 80]	The address is defined by the value set in the rotary switches
Hardware + Software	[1..127]	The address is defined by the value set in the rotary switches added to the value of the software address (Rcanaddr)

CONTROL WITH PROFIBUS DP

Profibus DP is an open industrial standard for integrated communication. It is a serial fieldbus, which permits the decentralized connection between sensors, actuators, drives and I/O modules of different brands, and provide for their connection with sub-ordered control systems.

Profibus DP (Distributed Periphery - Master/slave network) is a Profibus communication profile with optimized performances as regards speed, efficiency and connection costs. It is particularly suitable for the communication between automation systems and distributed peripheral devices .

The Profibus-DP network supports multi-masters systems with several slaves.

GENERAL CHARACTERISTICS

The drives SMD1204xIP can receive commands and parameters via Profibus communication network.

Profibus uses the RS-485 connection standard, which, according to the EN 50170/DIN 19245 standard, defines the signals levels and the physical characteristics of the communication channel.

The communication protocol (Profibus) defines the syntax and the coding of the data sent via physical channel, in order to unify the interfacing mode between devices of different manufacturers and to make the use of the bus easy and transparent for the user.

To simplify the interconnection of different motion control devices (drives), Profibus International created a specific profile for the transmission of the information toward the drives, named ProfiDRIVE.

Besides defining a standard channel communication and the management of the data onto the same, the type of connectors and the their pinouts have been determined, with the aim to provide a significant advantage to the user, giving the possibility to switch from a drive to another in case of necessity, knowing that nothing will change as for the Profibus communication.

SUPPORTED FUNCTIONS

Function	Real-time motion control, configuration and parameterization, programming, diagnostic
Protocol	PROFIdrive according to Profile Drive Technology specifications version 4.1, May 2006 (IEC 61800-7)
Mode	Autobitrate, Sync Mode, Fail Safe, DP-V0 (Standard Telegram 7,8,9 and PKW Telegram), DP-V1, I&M, Positioning Mode, Telegram configuring, Fault Buffer
Error Control	Checksum, DP-V1 Watchdog 1ms
Supported Master	Class 1, Class 2
Application Class	3 (Single axis positioning drive, with local motion control)
Traversing Tasks	64

ARCHITECTURE

The control chain of the VectorStep drives is composed in levels, in order to guarantee the maximum efficiency and safety in the management of movements and control signals of the motor.

The “thinking head” of the system is the motion controller, which has the task to collect the commands and the information from the “external world” and to elaborate and convert them in signals to be sent to the power stage.

The commands sent from the Profibus DP network, before being sent to the motion controller, are translated (interpreted) from the interpreter so that to standardize the requests.

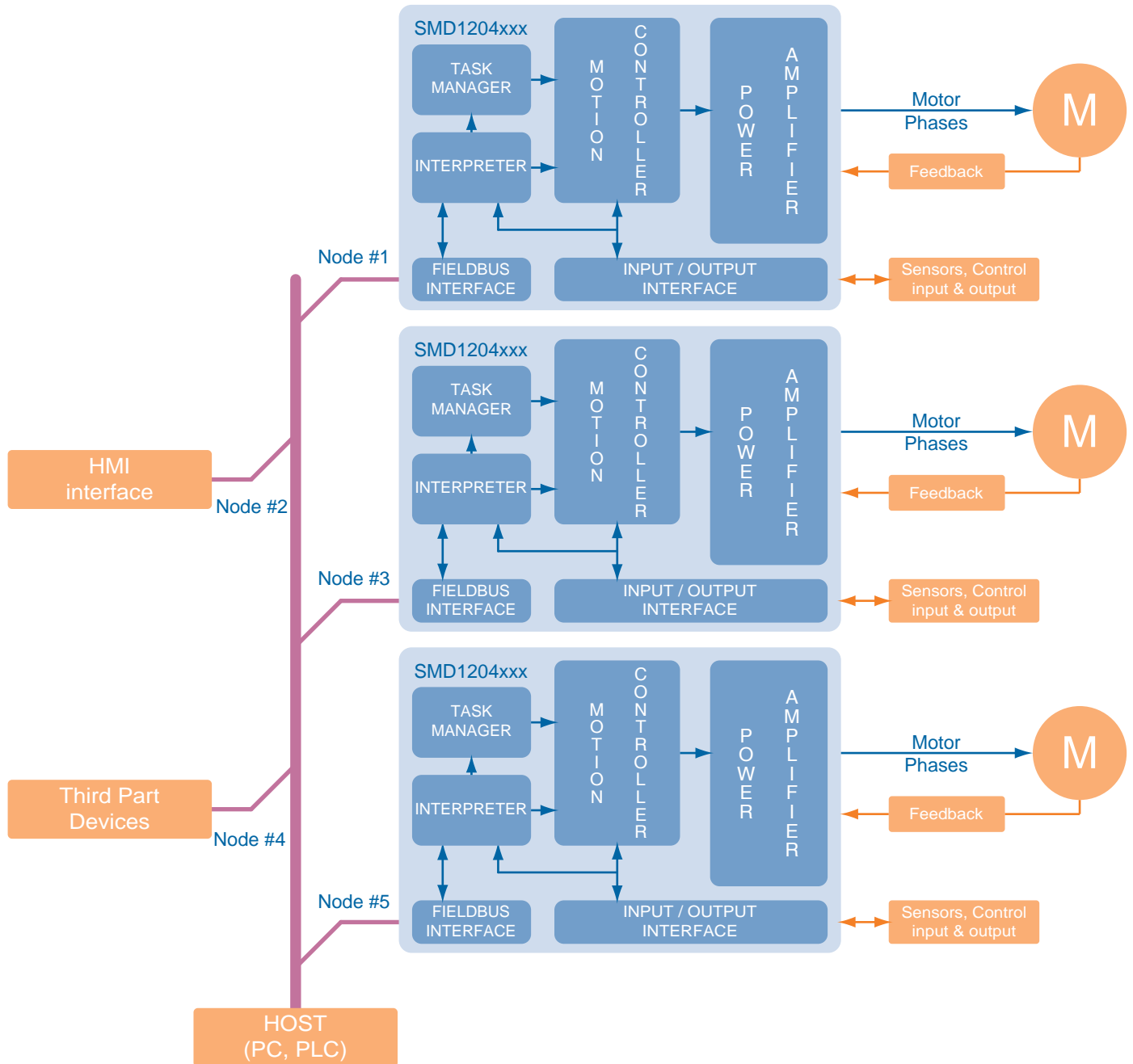

COMMUNICATION SPEED

The SMD1204xIP is able to communicate with a baudrate between 9,6Kbps and 12000 Kbps, automatically recognizing the communication speed of the network it's inserted in.

ADDRESSING

A Profibus network can support up to 127 nodes; each node must have a valid and unique address in the range 1 - 127.

L'indirizzo del nodo può essere assegnato in due modi:

Tipo	Range	Description
Hardware	[1 .. 80]	The address is defined by the value set in the rotary switches
Hardware + Software	[1..127]	The address is defined by the value set in the rotary switches added to the value of the software address (Rprofiaddr)

CONTROL WITH MODBUS TCP/IP

GENERAL CHARACTERISTICS

The drive SMD1204 LIE with Modbus TCP/IP fieldbus is equipped with a standard Ethernet 100Mb interface.

What is Modbus TCP/IP?

Modbus TCP/IP (or Modbus-TCP) is a version of Modbus RTU protocol, equipped with a TCP interface that runs on Ethernet.

The Modbus messaging structure is the application protocol that defines the rules for organizing and interpreting the data independently of the data transmission medium.

TCP/IP refers to the Transmission Control Protocol and Internet Protocol, which provides the transmission medium for Modbus TCP/IP messaging.

In simple terms, the TCP/IP standard allows blocks of binary data to be exchanged between computers. It is also a world-wide standard that serves as the foundation for the World Wide Web.

The primary function of TCP is to ensure that all packets of data are received correctly, while IP makes sure that messages are correctly addressed and routed.

It's important to note that the TCP/IP combination is merely a transport protocol, and does not define what the data means or how the data is to be interpreted (this is the job of the application protocol, Modbus in this case).

So in summary, Modbus TCP/IP uses TCP/IP and Ethernet to carry the data of the Modbus message structure between compatible devices.

Modbus TCP/IP combines a physical network (Ethernet), with a networking standard (TCP/IP), and a standard method of representing data (Modbus as the application protocol).

Essentially, the Modbus TCP/IP message is simply a Modbus communication encapsulated in an Ethernet TCP/IP wrapper.

Modbus TCP embeds a standard Modbus data frame into a TCP frame, without the Modbus check-sum, as shown in the following diagram:

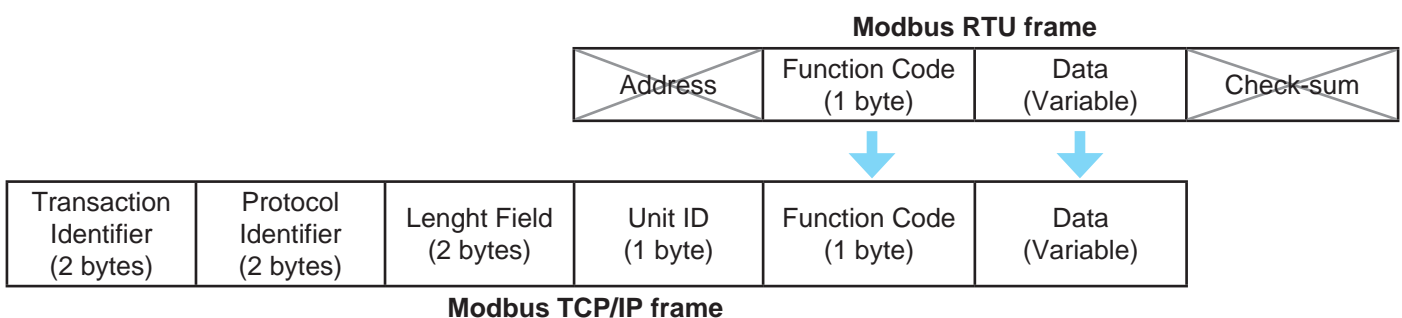

The Modbus commands and user data are themselves encapsulated into the data container of a TCP/IP telegram without being modified in any way.

However, the Modbus error checking field (check-sum) is not used, as the standard Ethernet TCP/IP link layer check-sum methods are instead used to guaranty data integrity.

Further, the Modbus frame address field is supplanted by the unit identifier in Modbus TCP/IP, and becomes part of the Modbus Application Protocol header.

Which TCP port is used by Modbus TCP/IP?

The complete Modbus TCP/IP Application Data Unit is embedded into the data field of a standard TCP frame and sent via TCP to well-known system port 502, which is specifically reserved for Modbus applications. Modbus TCP/IP clients and servers listen and receive Modbus data via port 502.

ARCHITECTURE

The control chain of the VectorStep drives is composed in levels, in order to guarantee the maximum efficiency and safety in the management of movements and control signals of the motor.

The “thinking head” of the system is the motion controller, which has the task to collect the commands and the information from the “external world” and to elaborate and convert them in signals to be sent to the power stage.

The information elaborated by the motion controller may result from multiple channels:

- digital and/or analog inputs/outputs interface;
- fieldbus interface;

The commands sent via Modbus TCP/IP, before being sent to the motion controller, are translated (interpreted) from the interpreter so that to standardize the requests.

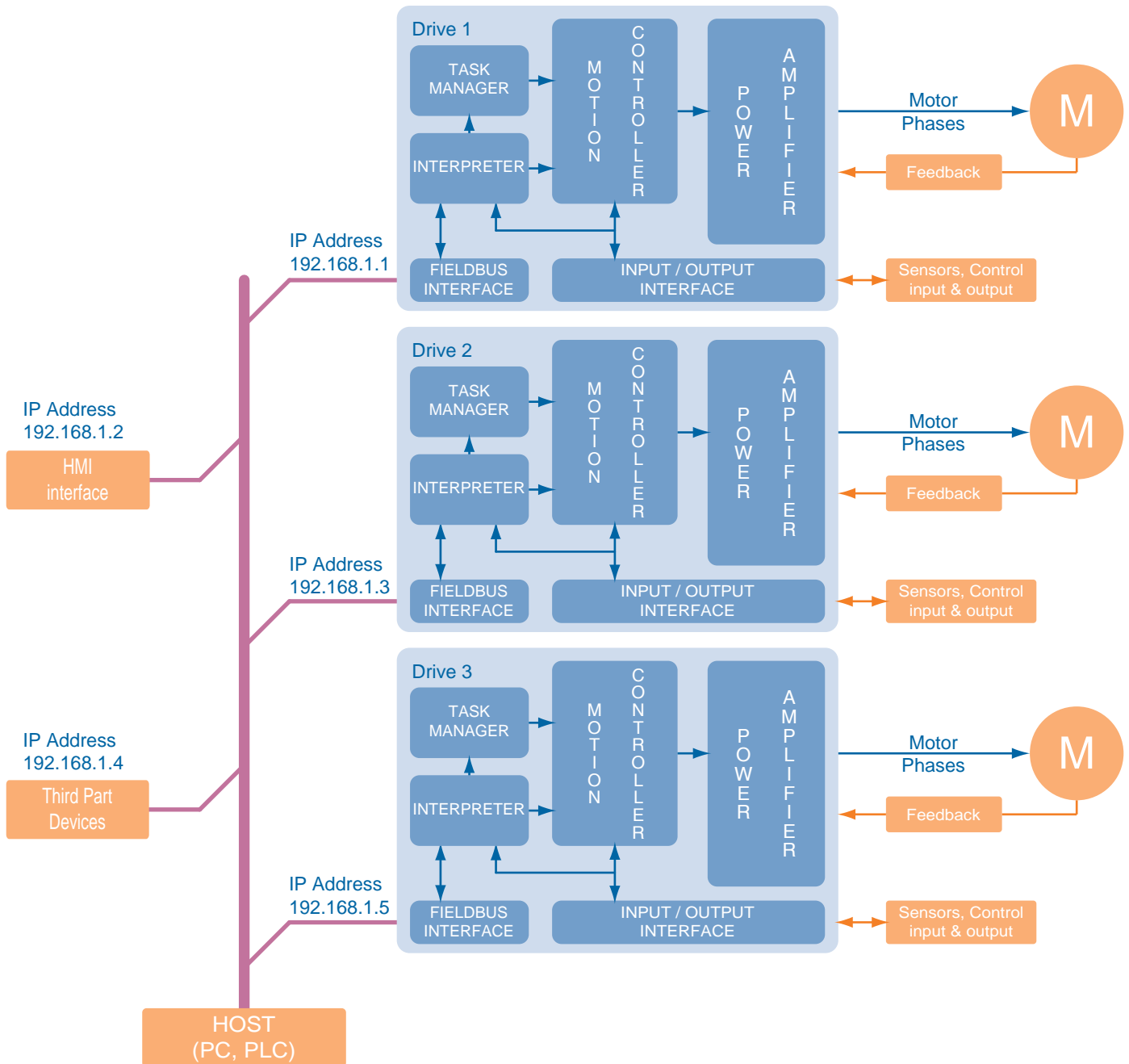

COMMUNICATION PARAMETERS

The SMD1204xIE supports The modbus communication both with TCP and UPD protocol.

Register	Name	Description						
Rmdbport	TCP port number	TCP port number (default is 502)						
Rintmot	Multiple access data format	Define the access method to multiple registers (32bit) via Modbus: <table border="1" style="width: 100%; border-collapse: collapse;"> <thead> <tr> <th style="width: 15%;">Value</th> <th>Description</th> </tr> </thead> <tbody> <tr> <td>0x00</td> <td> Little Endian (INTEL) When accessing a 32 bit data (2 holding registers) the least significant data (LSB) is transferred before the most significant data (MSB). Host → <input style="width: 100px;" type="text"/> → SMD1204xx </td> </tr> <tr> <td>0x01</td> <td> Big Endian (MOTOROLA) When accessing a 32 bit data (2 holding registers) the most significant data (MSB) is transferred before the least significant data (LSB) Host → <input style="width: 100px;" type="text"/> → SMD1204xx </td> </tr> </tbody> </table>	Value	Description	0x00	Little Endian (INTEL) When accessing a 32 bit data (2 holding registers) the least significant data (LSB) is transferred before the most significant data (MSB). Host → <input style="width: 100px;" type="text"/> → SMD1204xx	0x01	Big Endian (MOTOROLA) When accessing a 32 bit data (2 holding registers) the most significant data (MSB) is transferred before the least significant data (LSB) Host → <input style="width: 100px;" type="text"/> → SMD1204xx
Value	Description							
0x00	Little Endian (INTEL) When accessing a 32 bit data (2 holding registers) the least significant data (LSB) is transferred before the most significant data (MSB). Host → <input style="width: 100px;" type="text"/> → SMD1204xx							
0x01	Big Endian (MOTOROLA) When accessing a 32 bit data (2 holding registers) the most significant data (MSB) is transferred before the least significant data (LSB) Host → <input style="width: 100px;" type="text"/> → SMD1204xx							
Rethlocipaddr32	Ethernet local IP address	Byte 3 - Byte 2 Ethernet local IP address						
Rethlocipaddr10	Ethernet local IP address	Byte 1 - Byte 0 Ethernet local IP address						
Rethgwaddr32	Gateway address ethernet	Byte 3 - Byte 2 Gateway address ethernet						
Rethgwaddr10	Gateway address ethernet	Byte 1 – Byte 0 Gateway address ethernet						
Rethsubnet32	Subnet ethernet	Byte 3 - Byte 2 Subnet ethernet						
Rethsubnet10	Subnet ethernet	Byte 1 - Byte 0 Subnet ethernet						

IP ADDRESS SETTING

To set the IP address, you have to connect the PC to the drive using a USB cable and StepControl software. Once in the StepControl environment, go to “Parameters” menu and select “Communication Parameters”.

In the tab “Ethernet Parameters” (see the picture below), it is possible to set the Modbus TCP. parameters. The “Data format” indicates the 32 bit read/write mode.

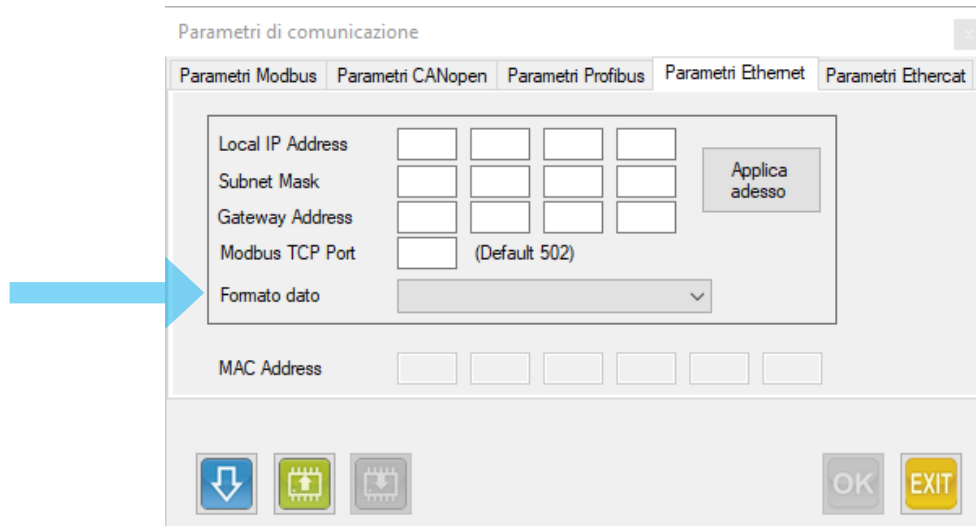

It is possible to choose between “Intel (Little Endian)” 32 bit mode (first read/write the lowest 16 bit word then the highest 16 bit word) or (Motorola (Big Endian)” 32 bit mode (first read/write the highest 16 bit word then the lowest 16 bit word).

After that, go to “Ethernet parameters” tab and set the local IP address, local sub-net mask, and the gateway IP address (not important).

Once all the requested data have been typed, press “Send data” (the blue down arrow button) to send the data to the drive. If the data must be stored in the non volatile memory, click on “Save data” (the green down arrow button).

If you want to apply the network address without switching off the drive, you can press “Apply now” and the network address change immediately.

Please note that the parameter “Data format” is updated only by switching off and restarting the drive.

CONTROL WITH ETHERCAT

GENERAL CHARACTERISTICS

EtherCAT (Ethernet Control Automation Technology) is a real-time industrial network system based on the Ethernet system, that can achieve faster and more efficient communications. Despite being a unique communication protocol, it uses the standard frames and the physical layers from the Ethernet standard IEEE 802.3.

Each node achieves a short cycle time by transmitting Ethernet frames at high speed. Each bus participant only takes the data which are intended for it, while the telegram which is sent by the bus master passes through it. Output data is inserted into the telegram in the same way. At the same time, the telegram is forwarded with a slight delay (a few nanoseconds). The bus participant recognises the commands which are intended for it and executes these. The last bus participant returns the completely processed telegram, so that it can be sent to the controller by the first bus participant as a response telegram.

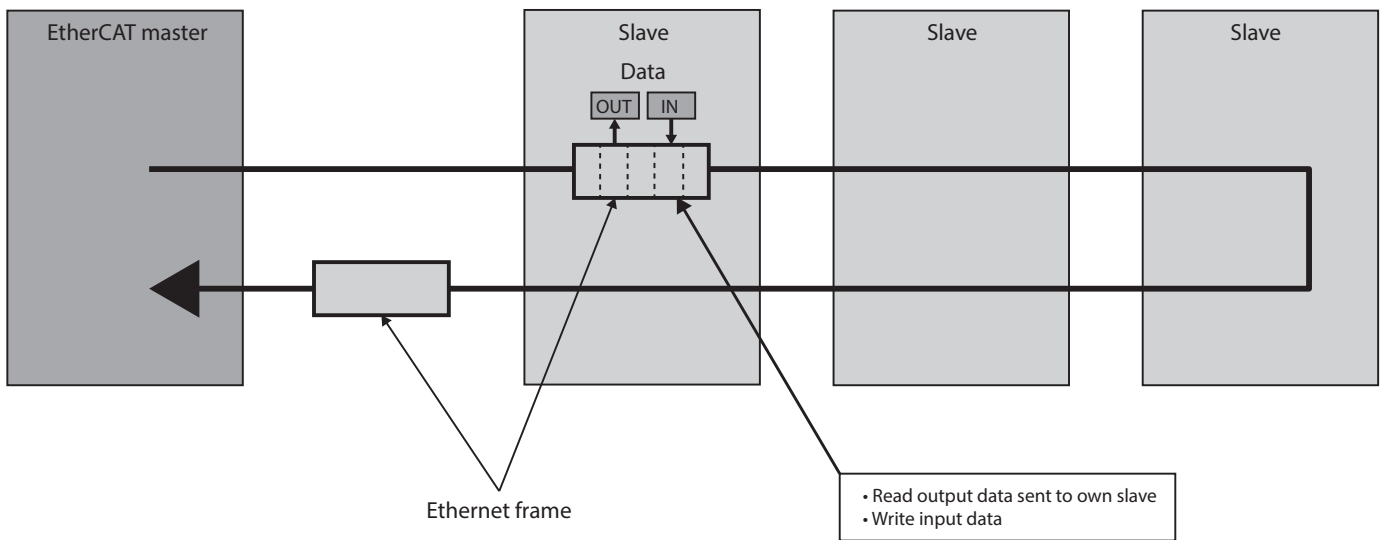

The EtherCAT protocol transports data directly within a standard Ethernet frame. Data is communicated between master and slaves in the form of process data objects (PDOs). Each PDO has an address to one particular slave or multiple slaves, and this “data and address” combination (plus the working counter for validation) makes up an EtherCAT telegram. If an Ethernet frame is compared to a “train,” an EtherCAT telegram would be a “compartment.”

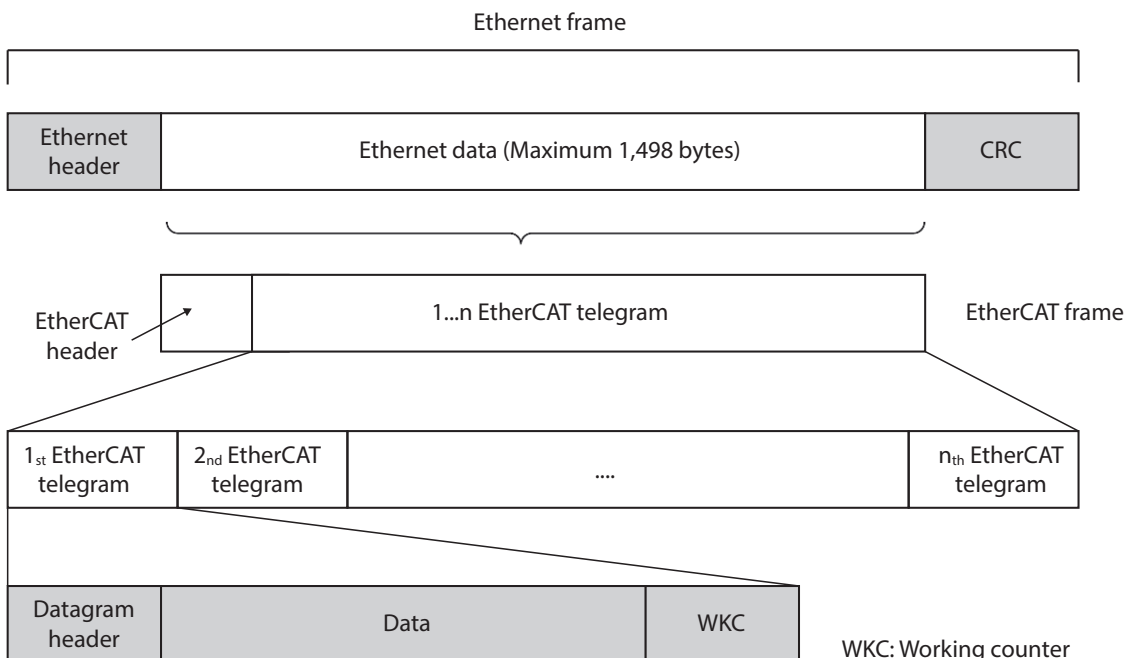

WKC: Working counter

CAN APPLICATION PROTOCOL OVER ETHERCAT

SMD1204xIT , SMD2204xIT and SMD5106xIT drives support CAN application protocol over EtherCAT (CoE). EtherCAT Slave structure is as below.

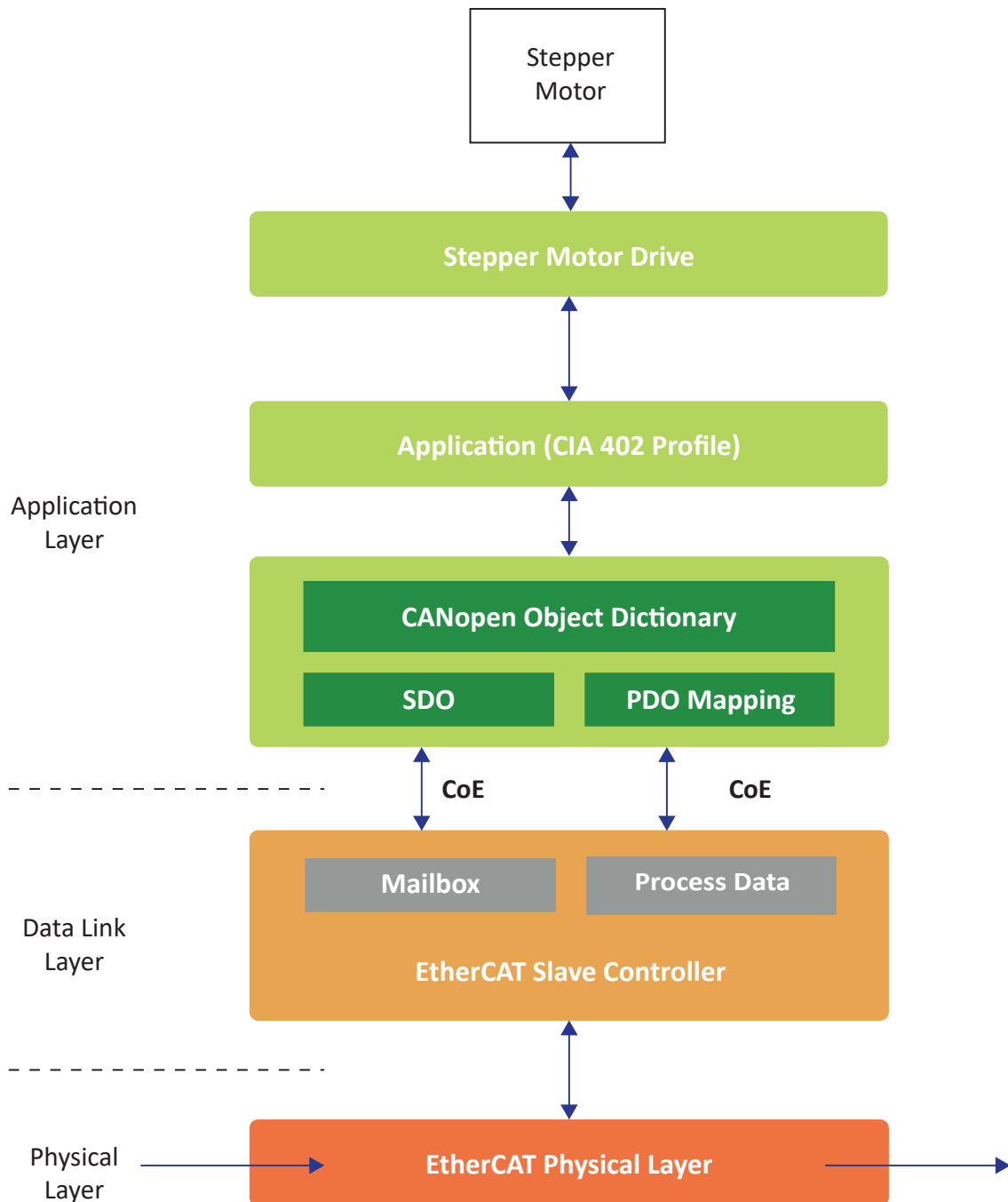

OBJECT DICTIONARY

In CANopen and EtherCAT, the object dictionary is a special area for the storage of parameters, application data and the PDO mapping, i.e. the mapping information between process data and application data.

The object dictionary is based on the CANopen standard which has later been extended by EtherCAT.

There are two types of communication functions available with EtherCAT: Mailbox communication and Process data communication.

MAILBOX COMMUNICATION (SDO COMMUNICATION)

Access to the object dictionary is possible via Service Data Objects (SDO) which provide a mailbox-based access functionality.

The EtherCAT master sends a command to the slaves, and then the slaves return a response to the EtherCAT master.

This communication can be used under Pre-Operation, Safe-Operation, Operation status of controller.

PROCESS DATA COMMUNICATION (PDO COMMUNICATION)

This refers to a cyclic (I/O) communication.

A cyclic (I/O) communication between the master and the slaves is achieved by mapping the logical process data space (cyclic data space) to each slave node by the EtherCAT master.

PDO communication is categorized as transmission PDO (following Tx PDO), which delivers controller status information and Receipt PDO (following Rx PDO), which delivers commands from master.

Rx PDO can be used under Operational status of controller.

Following is an example of PDO communication.

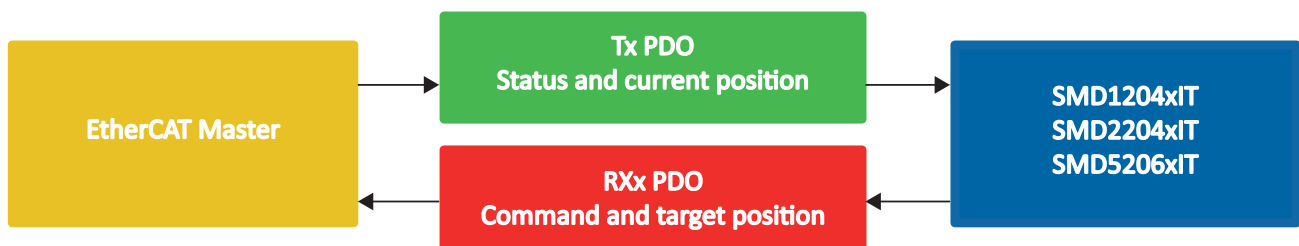

ETHERCAT ID SETTING

It is possible to assign a different EtherCAT ID than the default one assigned by the master by using the register “Rethercatid” (EtherCAT address 0x2165), or with the software StepControl (from the menu bar, “Parameters” - “Communication parameters” - “EtherCAT parameters”).

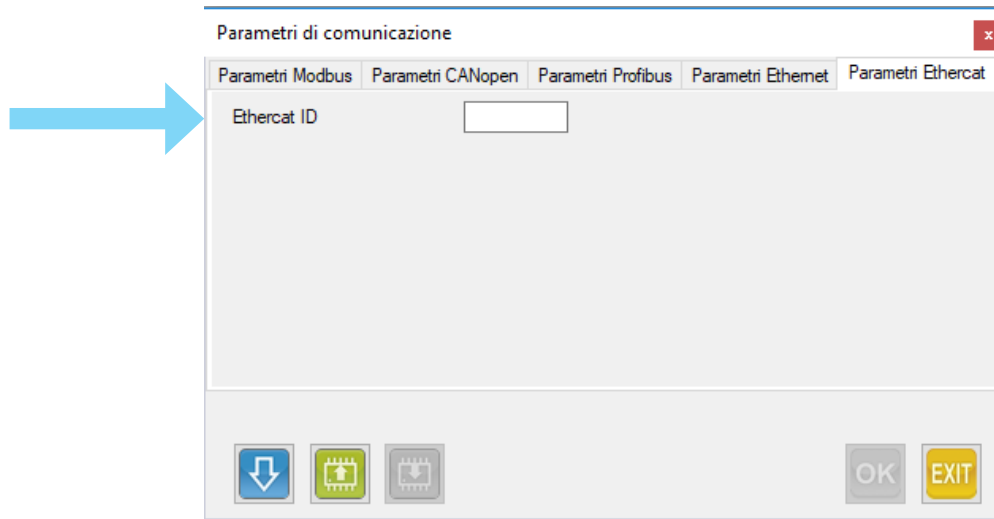

N.B.: For the changes to take effect, the drive needs to be rebooted.

CONTROL VIA PROFINET

OVERVIEW

The drives Profinet SMD1204xIN, SMD2204xIN e SMD5206xIN support several application profiles based on cyclic and acyclic communication services:

- PROFIdrive v.4.1 - Standard Telegram 9
- PROFIdrive v.4.1 - Base Mode Parameter Access (Acyclic Data Exchange)

CYCLIC AND ACYCLIC SERVICES

Normally, the data exchange uses cyclic and acyclic services.

For the cyclic data, the application profiles define:

- data independent from the manufacturers
- specific data for the manufacturer

The fixed setting and the use of the independent data from the manufacturer, permit to switch between them masters of different brand.

ACYCLIC READ/WRITE SERVICES

The acyclic Read/Write services provide access to data or parameters which cannot be accessed with cyclic data exchange.

ELECTRONIC FILE DESCRIPTION

The drives mod. SMD1204xIN, SMD2204xIN e SMD5206xIN are described by a GSDML file, used by Profinet configuration tools to obtain information on the devices themselves

GSDML files and icon files of the AEC's drives can be downloaded from the website www.aec-smd.it

The GSDML file and the icons are compressed into a .zip file, that has to be decompressed in the same folder of the hard disk.



THE DEVICES MAY PUT THEMSELVES INTO OPERATION WITHOUT NOTICE

Do not alter in any way the GSDML file. The alteration of the GSDML file may cause unexpected behaviour of the drives.

Failure to observe this precaution may cause injuries or damages to devices.

CAUTION!!! Any alteration to the GSDML file will void the AEC guarantee with immediate effect.

This chapter describes the functions and the procedures to use AEC's drives in Profinet. Please refer to Profinet Nutzerorganisation e.V. or visit the website www.profibus.com for further information on acyclic communication Profinet.

Profinet introduces a new service of acyclic read/write ; these communication services are embedded into special telegrams, that are inside the normal cyclic operativity of the bus.

The acyclic service permits to exchange volumes of data greater than the ones allowed by the cyclic service. At the same time, the communication will not be overloaded, because the acyclic communication telegram is added to the bus cycle only on request.

The Acyclic communication permits many features to the user:

- the master C1 can access in read/write to all the configuration and status parameters: registers, variables and tasks of the slave, and not only to the data contained in the cyclic process;
- the master C2 can access in read/write to all the configuration and status parameters: registers, variables and tasks of the slave;
- permits the access to the I&M (Information & Maintenance) of the drive

The following scheme summarizes the features of Profinet.

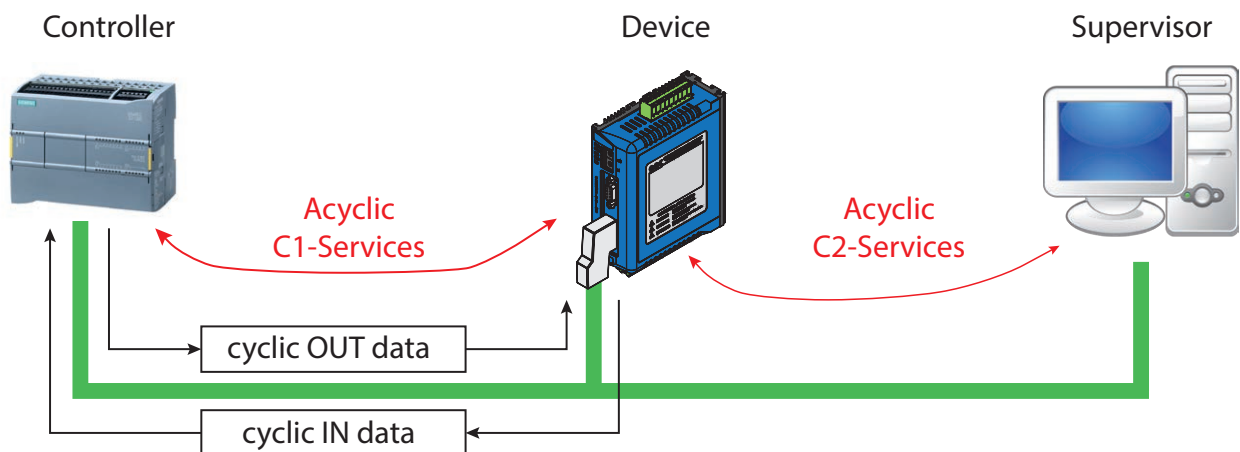

Nome	Descrizione
Controller	In a Profinet network, different classes of masters can coexist. The Controller manages the cyclic exchange with the slaves. Normally is the Controller (PLC), that manages the system automation. In case that the acyclic communication functionalities are enabled through the GSDML file, the acyclic connection between the Controller and Device is automatically enabled, in conjunction with the activation of the cyclic connection. In a Profinet network it is possible to use only one Controller.
Supervisor	The Supervisor are not able to execute cyclic exchange data with the Device. Normally, the Supervisor are visualization systems (eg. HMI) or analyses systems (network analyzers, notebook, PC), used only to monitor the state of the slaves or to alter some of their parameters.
Device	Stepper drive

SMD2204xIN 3 axis board, ProfiNet Slots Structure											
Slot 0 (API=0)		Slot 1 (API = 0x3A00 PROFIDrive)			Slot 2 (API = 0x3A00 PROFIDrive)			Slot 3 (API = 0x3A00 PROFIDrive)			
Subslot 0	Subslot 1	Subslot 2	Subslot 0	Subslot 1	Subslot 2	Subslot 0	Subslot 1	Subslot 2	Subslot 0	Subslot 1	Subslot 2
	Module Access Point (MAP) Contains parameters Access Point and alarm	Standard Telegram x (submodule ID = PROFIDrive telegram number)		Module Access Point (MAP) Contains parameters Access Point and alarm	Standard Telegram x (submodule ID = PROFIDrive telegram number)		Module Access Point (MAP) Contains parameters Access Point and alarm	Standard Telegram x (submodule ID = PROFIDrive telegram number)		Module Access Point (MAP) Contains parameters Access Point and alarm	Standard Telegram x (submodule ID = PROFIDrive telegram number)
P-Device		Drive Object 1			Drive Object 2			Drive Object 3			
SMD1204xIN SMD5206xIN 1AxLE board, ProfiNet slots structure											

CONTROL THROUGH INPUTS/OUTPUTS

The drives of the SMD1204 family are provided with a powerful and flexible digital/analog interface, which permits the control of the drive in a simple and intuitive way, without the necessity to build a program in the drive or to have complex control systems.

GENERAL CHARACTERISTICS

The SMD1204xxx are equipped with up to 10 digital inputs, up to 8 digital outputs, up to 3 analog inputs and 1 analog output.

It is possible to assign specific functions to the configurable inputs and outputs by setting few parameters.

Each input/output is associated with a configuration register, containing the assigned function.

SUPPORTED FUNCTIONS

Below are the functions that can be associated with the inputs and outputs, divided by category:

DIGITAL INPUTS

Configuration registers		Rfuni0, Rfuni1, Rfuni2, Rfuni3, Rfuni4, Rfuni5, Rfuni6, Rfuni7
Value	Function	Description
0	None	No associated function
1	Drive enable	Enable the output current to the motor
2	JOG CW	Move the motor forward at the speed set in the register Rvel
3	JOG CCW	Move the motor backward at the speed set in the register Rvel
4	Go to target quota	Position the motor at the absolute quota indicated in the register Rpostarg
5	Shift of the target quota	Position the motor at the relative quota indicated in the register Rpostarg
6	Homing	Start the search of the zero position
7	Bit 0 task selection	Bit 0 for the selection of the positioning sequence
8	Bit 1 task selection	Bit 1 for the selection of the positioning sequence
9	Bit 2 task selection	Bit 2 for the selection of the positioning sequence
10	Bit 3 task selection	Bit 3 for the selection of the positioning sequence
11	Bit 4 task selection	Bit 4 for the selection of the positioning sequence
12	Bit 5 task selection	Bit 5 for the selection of the positioning sequence
13	Bit 6 task selection	Bit 6 for the selection of the positioning sequence
14	Start Task	Start the configured positioning sequence
15	Alarms reset	Delete the alarms present
16	Quota alignment	Realign the actual position

DIGITAL OUTPUTS

Configuration registers		Rfuno0, Rfuno1, Rfuno2, Rfuno3, Rfuno4, Rfuno5, Rfuno6, Rfuno7
Value	Function	Description
0	None	No associated function
1	Drive enabled	Indicate if the drive is enabled
2	Alarm	Indicate the presence of an alarm
3	Synchronized axis	Indicate if the axis is homed
4	Axis in movement	Indicate if the axis is moving
5	Task in progress	Indicate if the drive is executing a positioning task
6	I2T	Indicate the occurrence of an I ² T alarm

ANALOG INPUT

Configuration registers		Rdefanainp
Value	Function	Description
137	None	No associated function
20	ESTOP delay	Set the number of steps to perform after a stop on event
24	STOP delay	Set the number of steps to perform after a stop
63	Speed	Set the rotation speed of the motor
67	Acceleration	Set the acceleration ramp
70	Deceleration	Set the deceleration ramp
83	Homing speed	Set the homing speed
87	Homing acceleration	Set the acceleration rampo during homing
213	Current limit	Set the current limit in closed-loop mode

PULSE TRAIN CONTROL (STEP AND DIRECTION)

Like all traditional stepper motors, also the VectorStep drives can be commanded with a train pulse in input.

The control in frequency and direction, particularly used in interpolated controllers, exploit the auxiliary encoder input of the SMD1204, with the possibility to use a simple pulse train and a digital signal to define the direction, or to use a two channels quadrature signal in frequency.

It is possible to control the drive in pulse train mode, both in open loop (stepper mode) and in closed loop (servo-mode), by properly configuring the drive with StepControl or via fieldbus.

K_p INCREMENT

When a traditional drive receives a pulse in the step input, it is generated an instant shift equal to the configured step angle (1,8° in case of full step, 0,9° in half step, 0,45° in quarter step, ecc), obtaining a jerky movement, with high resonances and a very high request of torque.

The VectorStep drives, instead, permit to move the rotor by interpolating some intermediate points, in order to obtain a smoother and silent movement, without resonances.

The K_p increment parameter defines the mode with which these points are interpolated.

By setting the K_{pinc} at 4096, the SMD1204 behave like a traditional drive, and it generated an instant movement equal to the configured step angle.

Lower is the value of K_{pinc}, greater is the number of interpolation points between a step and the next; the cycle time with which these intermediate points are generated is 250µs.

A smoother and more silent movement results in in a lower torque requested to the motor, with benefits in terms of performances and lesser mechanical stress of the system.

GAIN STEP (SERVO-MODE)

In closed loop operation (Servo-Mode), the feed rate is not defined anymore by the physical step of the motor, but from the resolution of the encoder (eg 512ppr encoder has a resolution of 1/2048 of step).

Gain Step parameter permits to amplify (via software) in frequency the step signal; increasing the Gain Step value results in increasing the shifting angle for each pulse in input.

In case of Gain Step = 1, the motor moves of one encoder pulse; with Gain Step = n, the shift of the motor will be equal to $1/n \times (Ris_{enc} \times 4)$.



CAUTION!!! The Step IN and Direction inputs are high frequency inputs. It is recommended the utmost care in wiring, shielding and posing of the signal cables. Keep a minimum distance of 300 mm from each power cable, place the signal cables and the power cables in different conduits inside the cabinet. In case it is not possible to avoid crossing with power cables, this intersection must be done with angles as near to 90° as possible. Connect the braided shield with the proper terminal block, ensuring a low impedance path to earth.

POSITIONING FUNCTIONS

The inputs and the outputs of the drives SMD1204 are configurable, with the possibility to associate specific functions with each of them.

Exploiting the I/O interface, the SMD1204 is able to perform positionings without the necessity of a program or a fieldbus.

The drive uses the internal parameters (configurable by the user via StepControl, HMI or fieldbus) to realize the requested movements.

The functions associated with the inputs are configured via StepControl (menu bar - View > Inputs and Outputs ) or via fieldbus, by writing in the configuration registers of the inputs.

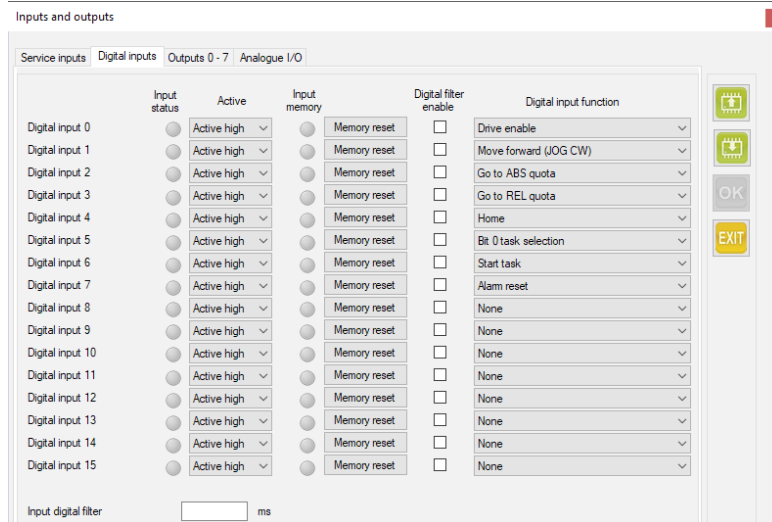

The functions available for the inputs are:

Function	Configuration			Description
	Register	Value	Description	
Enable drive	Rfunix	1	Inputs configuration (x = nr. of the input)	By activating the input "Enable drive", the current output to the motor is enabled if the drive has been correctly configured (Rconfig). Otherwise, the drive will remain disabled and the "Drive enabled" output will not be set.
JOG	Rfunix	2 3	Inputs configuration (2 = JOG CW 3 = JOG CCW)	Move the motor in forward or backward direction, with the parameters defined in the registers Rvel, Racc and Rdec.
	Rvel	Translation speed		
	Racc	Acceleration ramp		
	Rdec	Deceleration ramp		
Go to ABS quota	Rfunix	4	Inputs configuration	Position the motor at the absolute quota indicated in the register Rpostarg using the parameters Rvel, Racc and Rdec.
	Rpostarg	Target quota		
	Rvel	Translation speed		
	Racc	Acceleration ramp		
	Rdec	Deceleration ramp		
Go to REL quota	Rfunix	5	Inputs configuration	Shift the motor of the relative quota indicated in the register Rpostarg using the parameters Rvel, Racc and Rdec.
	Rpostarg	Target quota		
	Rvel	Translation speed		
	Racc	Acceleration ramp		
	Rdec	Deceleration ramp		

Function	Configuration			Description
	Register	Value	Description	
Home	Rfunix	6	Inputs configuration	Homing of the axis using the parameters defined in the registers Rhmode, Rhvh, Rhvl, Rhacc, Rhtinv, Rhofs, Rhmaxspc.
	Rpostarg	Target quota		
	Rhmode	Homing mode		
	Rhvh	Speed during the limit switch search		
	Rhvl	Speed during the zero point search		
	Rhacc	Acceleration ramp		
	Rhtinv	Inversion time		
	Rhofs	Homing offset		
	Rhmaxspc	Homing maximum space		
Bit x task selection	Rfunix		Inputs configuration	Positioning sequence selection inputs. The configured value is copied in the register Rtasknum. There are 64 positioning sequences, each one of them defines target quota, speed, acceleration, deceleration and a delay pre or post execution. The sequences can be concatenated, so that at the end of the first sequence a second one is automatically performed. There's no limit to the number of admitted concatenations.
		7	Bit 0 Task Sel.	
		8	Bit 1 Task Sel.	
		9	Bit 2 Task Sel.	
		10	Bit 3 Task Sel.	
		11	Bit 4 Task Sel.	
		12	Bit 5 Task Sel.	
13	Bit 6 Task Sel.			
Start Task	Rfunix	14	Inputs configuration	Start the positioning sequence defined in the register Rtasknum.
	Rtasknum	Number of the active task		
Cancella allarmi	Rfunix	15	Inputs configuration	Delete the active alarms.

The functions available for the outputs are:

Function	Configuration			Description
	Register	Value	Description	
Drive enabled	Rfunox	1	Outputs configuration (x = nr. of the output)	Activated when the drive supplies current to the motor and it is ready to operate.
Fault present	Rfunox	2	Outputs configuration	Indicate the presence of an alarm in the drive, either hardware or software.
Axis referenced	Rfunox	3	Outputs configuration	Activated when the axis performed the homing sequence and it is referenced.
Axis moving	Rfunox	4	Outputs configuration	Activated when the motor is performing a movement.
Task in progress	Rfunox	5	Outputs configuration	Activated when the motor is performing a positioning task.
I2T	Rfunox	6	Outputs configuration	Activated in presence of an I ² T alarm.
In position	Rfunox	7	Outputs configuration	Activated when the motor is inside the positioning window (Servo-Mode)

SPECIAL FUNCTIONS

In addition to the positioning functions, it is possible to associate the inputs with some special functions, including quota realignment.

The drive uses the internal parameters (configurable by the user via StepControl, HMI or fieldbus) to realize the requested movements.

The functions associated with the inputs are configured via StepControl (menu bar - View > Inputs and Outputs ) or via fieldbus, by writing in the configuration registers of the inputs.

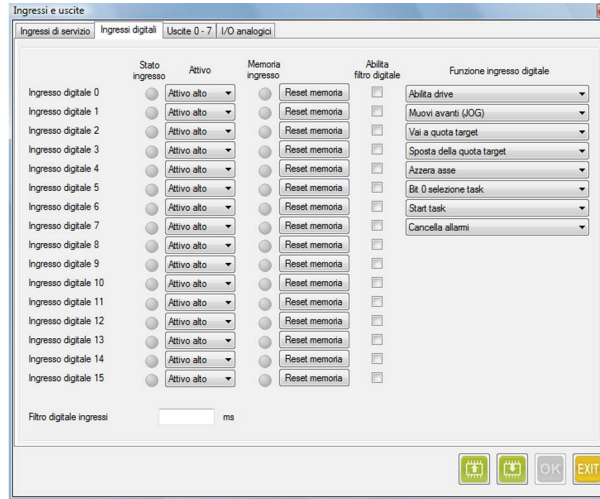

The special functions available for the inputs are:

Function	Configuration			Description
	Register	Value	Description	
Realigns quote	Rfunix	16	Inputs configuration	Activating the input "Realigns quote" it is possible to write in the registers <i>Actual position</i> (Rposact), <i>Motor encoder actual position</i> (Rmotenc) and <i>Auxiliary encoder actual position</i> (Rextenc) some default values to realign the quotas on-the-fly.
	Rlineupcmd		Align the quotas of the enabled registers	
	Rlineupdef		Define the registers to be realigned	
	Rlineuppos		Realignment quota (Rposact)	
	Rlineupmotenc		Realignment quota (Rmotenc)	
	Rlineupextenc		Realignment quota (Rextenc)	

START-UP PARAMETERS

GENERAL CHARACTERISTICS

The SMD1204 are “smart” programmable drives, able to perform small stand-alone automations, without being connected to other control devices like PCs or PLCs.

For this reason, it is of utmost importance to define the behavior of the drive at the start-up.

It is possible to indicate if the drive must independently load the saved configuration, to set some default parameters and to enable hardware and software limits.

AUTORUN

The Autorun parameter defines the behavior of the drive at the start-up; it is possible to choose between three options:

Register	Value	Function	Description
Rstrtmode	0	None	Load the default values without performing any other operation
	1	Configure the drive	Load the default values and set the operation mode
	2	Enable the drive	Load the default values, set the operation mode and enable the current output
	3	Start the program	Load the default values, set the operation mode, enable the current output and run the program



HARDWARE AND SOFTWARE LIMITS

Permits to enable the automatic management of the hardware limit switches and software limit quotas at the start-up.

Register	Bit	Function	Description
Rflag	2	Lower Limit	Enable the management of the lower software limit
	3	Upper Limit	Enable the management of the upper software limit
	4	Backward Limit Switch	Enable the management of the backward limit switch
	5	Forward Limit Switch	Enable the management of the forward limit switch

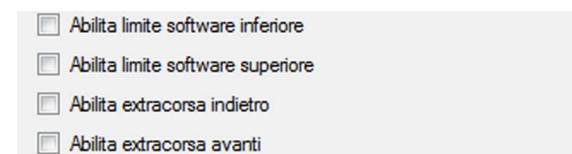

The intervention quotas of the software limits are defined by the registers Rupplim and Rlowlim.

In case of intervention of a limit switch, either software or hardware, the SMD1204 interrupts the movement in progress, sending an ABORT command, and disable any movement toward the direction of the intervened limit switch.

the re-enabling of the movement toward the direction of the intervened limit switch will automatically occur at the first movement in the opposite direction.



CAUTION!!! In case the axis physically exceeds the limit switch sensor during the stop in emergency ramp (ABORT), it is the user's responsibility to ensure that axis will be brought back inside the sensor itself before performing further movements toward the same direction. A too short movement in the opposite direction, in fact, reactivates the possibility to move in the direction of the intervened sensor, but doesn't grant the return of the axis inside the limit switches sensors.

LEVEL OF CURRENT

As already mentioned above, the VectorStep drives are able to manage three levels of current.

The start-up parameter *Level of current* indicates to the drive the level of current to be used at power-on.

Register	Value	Function	Description
Rcurmode	0	No current	Set the level of current to 0 ($I_{\text{fase}} = 0$)
	1	Reduced current	Set the lreduced evel of current ($I_{\text{fase}} = Rcurrred$)
	2	Nominal current	Set the nominal level of current ($I_{\text{fase}} = Rcurrnom$)
	3	Boost current	Set the current boost ($I_{\text{fase}} = Rcurboost$ during the acceleration/ deceleration ramps for a maximum time equal to Rtboost; $I_{\text{fase}} = Rcurrnom$ during the remaining part of the run)

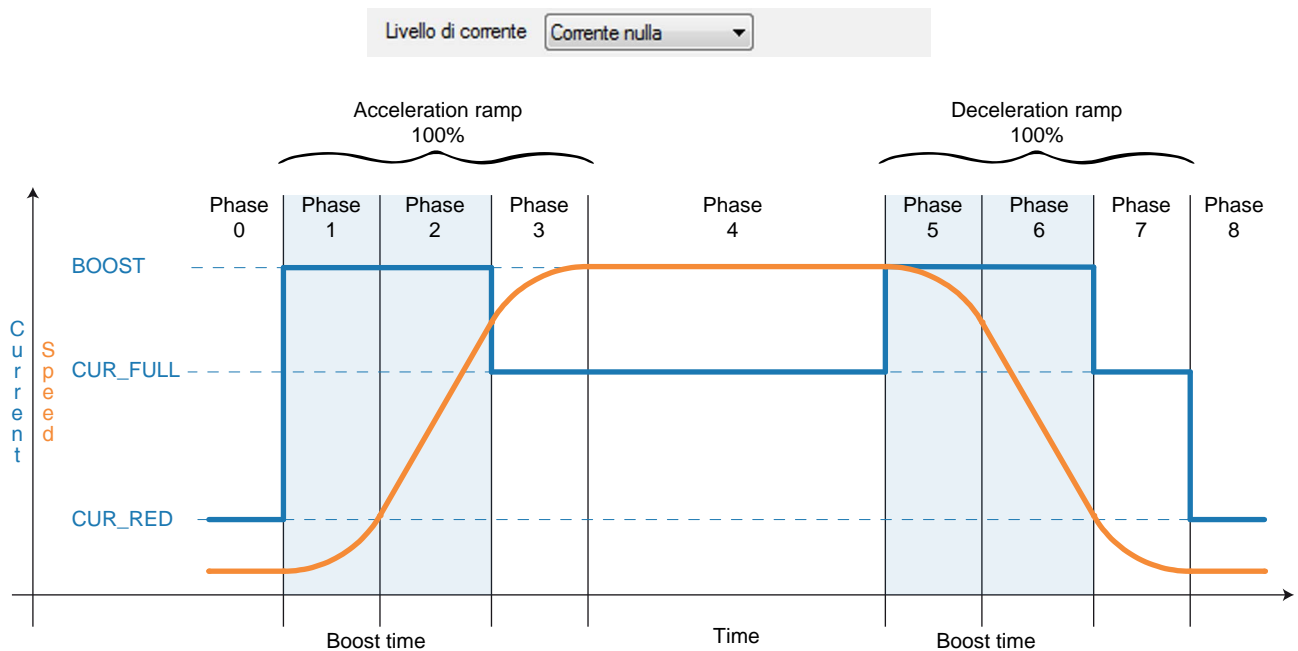

MOVEMENT PARAMETERS

Questo set di parametri definisce i valori di default che devono assumere i Movement parameters all'accensione.

Sono particolarmente utili nel caso si utilizzi l'azionamento controllandolo tramite ingressi e uscite senza la possibilità di inviare dati tramite o fieldbus e senza la necessità di programmare il drive stesso.

I parametri impostabili sono:

Register	Parameter	Description
Rstrtvel	Velocity	Define the translation velocity at the start-up
Rstrtvss	Start/Stop velocity	Define the start/stop velocity at the start-up
Rstrtacc	Acceleration	Define the acceleration ramp at the start-up
Rstrtdec	Deceleration	Define the deceleration ramp at the start-up
Rstrtpostarg	Target position	Define the target quota at the start-up

Movimento Azzeramento

Velocità rps x100

Velocità iniziale rps x100

Accelerazione rps² x10

Decelerazione rps² x10

Posizione target step



These parameters are used by the movement functions associated with the inputs to generate the movement profiles.

HOMING PARAMETERS

This set of parameters defines the default valued that the homing parameters must take at the power-on.

They are particularly useful in case the drive is used by controlling it via inputs and outputs, without the possibility to send data via fieldbus, and without the necessity to program the drive itself.

The configurable parameters are:

Register	Parameter	Description																																				
Rstrthvh	Velocity during switch search	Define the velocity during the search of the limit switch																																				
Rstrthvl	Velocity during zero point search	Define the velocity during the search of the zero point																																				
Rstrthacc	Acceleration ramp	Define the homing acceleration ramp																																				
Rstrthmode	Homing mode	Define the homing method <table border="1"> <thead> <tr> <th>Value</th> <th>Description</th> </tr> </thead> <tbody> <tr><td>0</td><td>No homing function requested</td></tr> <tr><td>-1</td><td>Homing only with BLS in negative direction</td></tr> <tr><td>-2</td><td>Homing only with BLS in positive direction</td></tr> <tr><td>-3</td><td>Homing with BLS + TOP rising edge, negative direction</td></tr> <tr><td>-4</td><td>Homing with BLS + TOP rising edge, positive direction</td></tr> <tr><td>-5</td><td>Homing only with TOP in negative direction</td></tr> <tr><td>-6</td><td>Homing only with TOP in positive direction</td></tr> <tr><td>-7</td><td>Homing with backward mechanical limit + axis measure</td></tr> <tr><td>-8</td><td>Homing with forward mechanical limit + axis measure</td></tr> <tr><td>-9</td><td>Homing with backward mechanical limit</td></tr> <tr><td>-10</td><td>Homing with forward mechanical limit</td></tr> <tr><td>-11</td><td>Homing with backward mechanical limit + encoder TOP</td></tr> <tr><td>-12</td><td>Homing with forward mechanical limit + encoder TOP</td></tr> <tr><td>-13</td><td>Homing on FLS, negative direction</td></tr> <tr><td>-14</td><td>Homing on FLS, positive direction</td></tr> <tr><td>-15</td><td>Homing on FLS + motor encoder TOP, negative direction</td></tr> <tr><td>-16</td><td>Homing on FLS + motor encoder TOP, positive direction</td></tr> </tbody> </table>	Value	Description	0	No homing function requested	-1	Homing only with BLS in negative direction	-2	Homing only with BLS in positive direction	-3	Homing with BLS + TOP rising edge, negative direction	-4	Homing with BLS + TOP rising edge, positive direction	-5	Homing only with TOP in negative direction	-6	Homing only with TOP in positive direction	-7	Homing with backward mechanical limit + axis measure	-8	Homing with forward mechanical limit + axis measure	-9	Homing with backward mechanical limit	-10	Homing with forward mechanical limit	-11	Homing with backward mechanical limit + encoder TOP	-12	Homing with forward mechanical limit + encoder TOP	-13	Homing on FLS, negative direction	-14	Homing on FLS, positive direction	-15	Homing on FLS + motor encoder TOP, negative direction	-16	Homing on FLS + motor encoder TOP, positive direction
Value	Description																																					
0	No homing function requested																																					
-1	Homing only with BLS in negative direction																																					
-2	Homing only with BLS in positive direction																																					
-3	Homing with BLS + TOP rising edge, negative direction																																					
-4	Homing with BLS + TOP rising edge, positive direction																																					
-5	Homing only with TOP in negative direction																																					
-6	Homing only with TOP in positive direction																																					
-7	Homing with backward mechanical limit + axis measure																																					
-8	Homing with forward mechanical limit + axis measure																																					
-9	Homing with backward mechanical limit																																					
-10	Homing with forward mechanical limit																																					
-11	Homing with backward mechanical limit + encoder TOP																																					
-12	Homing with forward mechanical limit + encoder TOP																																					
-13	Homing on FLS, negative direction																																					
-14	Homing on FLS, positive direction																																					
-15	Homing on FLS + motor encoder TOP, negative direction																																					
-16	Homing on FLS + motor encoder TOP, positive direction																																					
Rhmaxspc	Maximum space in Home	Define the maximum space during homing sequence																																				
Rhofs	Homing offset	Homing offset (Shift of the axis after home routine)																																				

Movimento Azzeramento

Velocita' di ricerca finecorsa rps x100

Velocità ricerca punto di 0 rps x100

Accelerazione rps² x10

Modo azzeramento

Spazio massimo counts

Offset counts

DRIVE GENERAL PARAMETERS

GENERAL CHARACTERISTICS

The general parameters of the drive are the general use parameters which permit to define and modify the working mode of the drive itself.

These include the control mode (Stepper mode, Servmo mode or Smart Mode), operation mode (Velocity, current, position or step/dir) and current level configuration registers.

CONTROL MODES

The control mode defines if the stepper motor must be controlled in open loop (Stepper mode) or closed loop (Servo Mode and Smart Mode).



CAUTION!!! It is possible to control the motor in closed loop only if the motor is equipped with an encoder. In case of use of the Servo Mode, the resolution of the motor (step/rev) depends on the number of pulses in quadrature of the encoder, not from the physical steps of the motor.

OPERATION MODE

The operation mode defines the control method of the motor. The drive can control the motor in velocity, in position or in current. Along with the *Control Modes* parameter, it sets the operation mode of the drive, by setting the value of the register Rconfig.

Register	Value	Description
Rconfig	0	Drive not configured
	1	Reserved
	2	Stepper Mode in velocity control
	3	Stepper Mode in position control
	4	Stepper Mode in step/direction control
	5	Servo Mode in current control
	6	Servo Mode in velocity control
	7	Servo Mode in position control
	8	Servo Mode in step/direction control
	9	Closed Loop / Speed (with tachometric – Only DMD)
	10	Reserved
	11	Smart Mode / Speed
	12	Smart Mode / Position
13	Smart Loop / Step-Direction	

SETTING OF THE CURRENT

This set of registers assign the value to the three levels of current used by the drives; it is possible to set values between 0 and the drive maximum admitted limit, with increments of 1mA.

Register	Name	Description
Rcurnom	<i>Nominal current</i>	Set the level of nominal current supplied by the drive in mA.
Rcurred	<i>Reduced current</i>	Set the level of reduced current in mA. The level of reduced current can be activated via command, or automatically by setting the parameter <i>AutoCR delay</i> .
Rcurboost	<i>Current boost</i>	Set the level of boost current in mA. If enabled, the drive over-supplies the motor during the the acceleration or deceleration ramps, for the maximum time set in the parameter <i>Boost time</i> .
Rtcred	<i>AutoCR delay</i>	Set the activation delay of the automatic current reduction in ms. If <i>Rtcred</i> = 0 the automatic reduction is disabled and the drive always remains in nominal current, also in standstill.
Rtboost	<i>Boost time</i>	Set the maximum duration of the boost current pulse in ms.



CAUTION!!! Pay particular attention in setting the parameters of current. Don't exceed the nominal current of the motor in order to avoid overheatings and fires. Make sure that power supplied to the motor complies the constructive characteristics of the same.

DRIVE ADVANCED PARAMETERS

GENERAL CHARACTERISTICS

This set of parameters permits to configure the advanced functions of the drives.

As already mentioned in the chapter 4.0, the drives SMD1204 uses a vector field oriented control technique, which permits to obtain an accurate and smooth control both in mechanical terms and in thermal dissipation.

The VectorStep drives are also provided with advanced controls on the profile of current, in order to optimize and compensate the deformations arising from constructive characteristics of the motor.

POSITION LOOP

The Position Loop (PL) is the outermost part of the controller, which interfaces with the command interpreter from which it obtains the movement requests.

It is used only in Servo Mode, because in the traditional operation mode of stepper motors (Stepper Mode) and in Smart Mode it is virtually generated inside the positioner.

The PL has the task to generate the velocity commands to be sent to the drive, in order to follow in the most accurate way the position setpoint set, reducing as far as possible the following error.

For this purpose, the PL uses an advanced PID control with predictive functions, in order to make the system stable also in case of sudden variations of the setpoint.

Register	Name	Description						
Rkppos	<i>Proportional gain</i>	Set the value of the proportional gain of the control loop. (affect the responsiveness of the system) $P(t) = K_p \times E_{pos}(t)$						
Rkipos	<i>Integral gain</i>	Set the value of the integral gain of the control loop. (reduce the error in Permanent Regime [constant setpoint] but reduce the responsiveness) $I(t) = K_i \times \sum_i(t)$						
Rkcipos	<i>Dynamic gain</i>	Set the emptying speed of the integral error. (in case of sudden variations of the setpoint, it limits and reduces the integral error in order to increase the responsiveness of the system) $\sum_i(t) = \sum_i(t-1) + K_{tci} \times E_{pos}(t)$						
Rkffpos	<i>Feed-Forward gain</i>	Set the Feed-Forward gain of the control loop (it's an open loop predictive type of contribution in velocity or current, proportional to the requested velocity, which permits to compensate the dynamic frictions and to reduce the integral contributions)						
Rkafpos	<i>Acceleration-Forward gain</i>	Set the Acceleration-Forward gain of the control loop (it's an open loop predictive type of contribution in velocity or current, proportional to the requested velocity, which permits to reduce the following error during the acceleration phases). <i><u>The use of this contribution is not advisable in variable inertia applications.</u></i>						
Rswacfw	<i>Switch Acceleration Forward</i>	Set the loop on which the Acceleration-Forward control acts. <table border="1" style="width: 100%; border-collapse: collapse;"> <thead> <tr> <th>Value</th> <th>Description</th> </tr> </thead> <tbody> <tr> <td style="text-align: center;">0</td> <td>Current loop (Recommended)</td> </tr> <tr> <td style="text-align: center;">1</td> <td>Velocity loop</td> </tr> </tbody> </table>	Value	Description	0	Current loop (Recommended)	1	Velocity loop
Value	Description							
0	Current loop (Recommended)							
1	Velocity loop							

Legend:

K_p = Proportional gain
 K_i = Integral gain
 K_{tci} = Dynamic integral coefficient

E_{pos} = Position error
 \sum_i = Integral summation

VELOCITY LOOP

The Velocity Loop (VL) is interposed between the Position Loop, from which receives the velocity setpoint, and the Current Loop, to which sends the requests of current.

It is used only in Servo Mode, because in the traditional operation mode of stepper motors (Stepper Mode) and in Smart Mode it is virtually generated inside the positioner.

The VL has the task to generate the commands of current to be sent to the drive, in order to follow in the most accurate way the velocity setpoint set, reducing as far as possible the following error.

For this purpose, the VL uses an advanced PID control with a dynamic integrator, in order to make the system stable also in case of sudden variations of the setpoint.

Register	Name	Description
Rkpvcl	<i>Proportional gain</i>	Set the value of the proportional gain of the control loop. (affect the responsiveness of the system) $V(t) = K_p \times E_{vel}(t)$
Rkivcl	<i>Integral gain</i>	Set the value of the integral gain of the control loop. (in case of sudden variations of the setpoint, it limits and reduces the integral error in order to increase the responsiveness of the system) $I(t) = K_i \times \sum_i(t)$
Rkciivcl	<i>Dynamic gain</i>	Set the emptying speed of the integral error. (in case of sudden variations of the setpoint, it limits and reduces the integral error in order to increase the responsiveness of the system) $\sum_i(t) = \sum_i(t-1) + K_{tci} \times E_{vel}(t)$

Legend:

Kp	=	Proportional gain	E_{vel}	=	Velocity error
Ki	=	Integral gain	\sum_i	=	Integral summation
Ktci	=	Dynamic integral coefficient			

CURRENT LOOP

The Current Loop (CL) is the last loop of the chain of control, and its general task is to generate the requests of current needed to move the motor.

It is used in Stepper Mode and Smart Mode, where it works at constant current (the level of current is not affected by load variations), and in Servo Mode, where the level of current supplied is proportional to the torque requested by the load.

The CL has the task to generate the control currents of the stepper motor, in order to generate the movement requested by the upper loops (PL and VL).

For this purpose, the position loop uses a dual PID control which permits to act both on the torque current (current in quadrature) and in holding current (direct current).

Register	Name	Description
Rkpid	<i>Holding current proportional gain (I_d)</i>	Set the proportional gain value of the I_d control loop. $I_d(t) = K_p \times E_{id}(t)$
Rkiid	<i>Holding current integral gain (I_d)</i>	Set the integral gain value of the I_d control loop. $I_d(t) = K_i \times \sum_{id}(t)$
Rkpiq	<i>Holding current proportional gain (I_q)</i>	Set the proportional gain value of the I_q control loop. $I_q(t) = K_p \times E_{iq}(t)$
Rkiiq	<i>Holding current integral gain (I_q)</i>	Set the integral gain value of the I_q control loop. $I_q(t) = K_i \times \sum_{iq}(t)$

Legend:

Kp	=	Proportional gain	E_{id}	=	I_d error of current
Ki	=	Integral gain	E_{iq}	=	I_q error of current
			\sum_{id}	=	I_d integral summation
			\sum_{iq}	=	I_q integral summation

PHASE ADVANCE

The Phase Advance control permits to progressively modify the drive angle of the vector, so that to reduce the counter-electromotive force (fcem) and to modify the effect of the torque current.

The applicable shift is inversely proportional to the load and the inertia of the same: greater is the load, lower must be the applied shift.

Too high values of the Phase Advance may cause system instability.

The Phase Advance control uses the following parameters:

Parameter	Name	Description
Rphgain	Phase Advance Gain	Set the Phase Advance gain.

In addition to obtain an increase of torque, the drive angle shift permits to reduce the system resonances.



CAUTION!!! Greater is the Phase Advance value, greater is the drive angle shift. Pay particular attention in adjusting this parameter. Too high values increase the instability of the system, bringing the drive in fault status.

MOTOR PARAMETERS

GENERAL CHARACTERISTICS

This set of parameters includes the physical and electric characteristics of the motor.

The configurations entered in these registers are used by the drive to rebuild the electric model of the motor in use, in order to adapt the control loops and obtain the best performances.

Also, it is possible to choose the operating resolution of the motor, (setting it in a range between full step and 1/1024 of step) and to define the number of pulses per revolution of the motor encoder, in case it is present.

ELECTRIC CHARACTERISTICS

Indicate the electric resistance, the inductance and the nominal current of the motor in use:

Register	Name	Description
Rmotres	Phase resistance	Set the phase resistance of the motor in use, expressed in tenths of Ω .
Rmotind	Phase inductance	Set the phase inductance of the motor in use, expressed in tenths of mH.
Rmotlph	Nominal current	Set the nominal current of the motor in use, expressed in mA.



CAUTION!!! Entering wrong parameters may result in an increase of the resonances, of instabilities and in a non-optimal management of the motor.

PHYSICAL CHARACTERISTICS

Indicate the torque constant and the counter-electromotive force constant of the motor in use:

Register	Name	Description
Rmotkfm	Counter-electromotive force constant	Set the counter-electromotive force constant of the motor, expressed in hundredths of mHA (milliHenry per Ampere). (see "Calculation of the counter-electromotive force constant")
Rmotktq	Torque constant	Set the torque constant of the motor, expressed in mNm/A (milliNewtonmeter per Ampere) (see "Calculation of the torque constant")

Calculation of the torque constant:

Legend:

I_{NOM} = Nominal phase current (A)

T_{NOM} = Nominal torque (Nm)

K_{TQ} = Torque constant (mNm/A)

$$K_{TQ} = \frac{T_{NOM} \times 1000}{I_{NOM}}$$

Calculation of the counter-electromotive force constant:

Legend:

I_{NOM} = Nominal phase current (A)

L_{NOM} = Phase inductance (mH)

K_{FM} = Counter-electromotive force constant (mH/A)

$$K_{FM} = \frac{L_{NOM} \times I_{NOM} \times 100}{1000}$$



CAUTION!!! Entering wrong parameters may result in an increase of the resonances, of instabilities and in a non-optimal management of the motor.

STEP RESOLUTION

Set the operating resolution of the system:

Register	Name	Description			
Rstpres	<i>Step resolution</i>	Indicate the number of microsteps (software) in which a physical step will be divided (eg. with Rstpres = 2, each physical step is divided into 2 microsteps).			
		Value	Description	Value	Description
		1	Full step	64	64 th of step
		2	Half step	128	128 th of step
		4	Quarter of step	256	256 th of step
		8	8 th of step	512	512 th of step
		16	16 th of step	1024	1024 th of step
		32	32 th of step		

ENCODER RESOLUTION

Set the resolution of the motor encoder:

Register	Name	Description
Rmotencpuls	<i>Motor encoder resolution</i>	Indicate the number of pulses per revolution of the encoder connected to the motor.



CAUTION!!! Entering a wrong resolution will result in generating an encoder phasing alarm (with Smart mode and Servo mode).

INPUTS AND OUTPUTS PARAMETERS

GENERAL CHARACTERISTICS

The VectorStep drives have multiple lines of digital I/O, which can be used for general purpose or with specific functions (limit switches, zero TOP, encoder inputs), besides some analog I/O lines for general purpose. Each I/O line has some associated registers, which permit to define the operation modes.

SERVICE INPUTS

The service inputs are 8 lines of PNP/NPN or Line Driver (0-24Vdc and TTL compatible) digital inputs that, in particular situations, take a specific function.

The service inputs are associated with 5 registers that permit to know the state of each input and to configure the functioning:

Register	Name	Description																		
Rlsi	<i>Service inputs state</i>	Indica the state of each single service input (read only)																		
		<table border="1"> <thead> <tr> <th>Bit</th> <th>Description</th> </tr> </thead> <tbody> <tr> <td>0</td> <td>FLS (Forward limit switch)</td> </tr> <tr> <td>1</td> <td>BLS (Backward limit switch)</td> </tr> <tr> <td>2</td> <td>TOP_M (Motor encoder index)</td> </tr> <tr> <td>3</td> <td>CH.A_M (Motor encoder channel A)</td> </tr> <tr> <td>4</td> <td>CH.B_M (Motor encoder channel B)</td> </tr> <tr> <td>5</td> <td>TOP_A (Auxiliary encoder index)</td> </tr> <tr> <td>6</td> <td>CH.A_A (Auxiliary encoder channel A)</td> </tr> <tr> <td>7</td> <td>CH.B_A (Auxiliary encoder channel B)</td> </tr> </tbody> </table>	Bit	Description	0	FLS (Forward limit switch)	1	BLS (Backward limit switch)	2	TOP_M (Motor encoder index)	3	CH.A_M (Motor encoder channel A)	4	CH.B_M (Motor encoder channel B)	5	TOP_A (Auxiliary encoder index)	6	CH.A_A (Auxiliary encoder channel A)	7	CH.B_A (Auxiliary encoder channel B)
		Bit	Description																	
		0	FLS (Forward limit switch)																	
		1	BLS (Backward limit switch)																	
		2	TOP_M (Motor encoder index)																	
		3	CH.A_M (Motor encoder channel A)																	
		4	CH.B_M (Motor encoder channel B)																	
		5	TOP_A (Auxiliary encoder index)																	
6	CH.A_A (Auxiliary encoder channel A)																			
7	CH.B_A (Auxiliary encoder channel B)																			
Rdeflsi	<i>Service inputs definition</i>	Define the active state of the input: if Bit = 0, active high, if Bit = 1, active low <i>(For the bit mapping, see Rlsi table)</i>																		
Rfillsi	<i>Service inputs digital filter</i>	Set the digital filter time (expressed in ms) of the service inputs bank																		
Renfisi	<i>Digital filter enabling mask</i>	Permit to define on which inputs the digital filter must be activated, by raising the bit of the desired input (Bit = 1 → Filter enabled) <i>(For the bit mapping, see Rlsi table)</i>																		
Rmemlsi	<i>Service inputs state memory</i>	Store the (active) state of each service input; the bit of the input remains high until the reset of the same by the user. <i>(For the bit mapping, see Rlsi table)</i>																		

DIGITAL INPUTS

The SMD1204 provides up to 10 lines of PNP digital inputs (0-24Vdc and TTL compatible) for general purpose; these inputs can be associated with specific functions.

The inputs are associated with 6 registers, which permit to know their state and to configure the functioning:

Register	Name	Description																		
Rinp	<i>Inputs state</i>	Indicate the state of each input (read only)																		
		<table border="1"> <thead> <tr> <th>Bit</th> <th>Description</th> </tr> </thead> <tbody> <tr> <td>0</td> <td>Input 0</td> </tr> <tr> <td>1</td> <td>Input 1</td> </tr> <tr> <td>2</td> <td>Input 2</td> </tr> <tr> <td>3</td> <td>Input 3</td> </tr> <tr> <td>4</td> <td>Input 4</td> </tr> <tr> <td>5</td> <td>Input 5</td> </tr> <tr> <td>6</td> <td>Input 6</td> </tr> <tr> <td>7</td> <td>Input 7</td> </tr> </tbody> </table>	Bit	Description	0	Input 0	1	Input 1	2	Input 2	3	Input 3	4	Input 4	5	Input 5	6	Input 6	7	Input 7
		Bit	Description																	
		0	Input 0																	
		1	Input 1																	
		2	Input 2																	
		3	Input 3																	
		4	Input 4																	
		5	Input 5																	
6	Input 6																			
7	Input 7																			

Register	Name	Description																																																																		
Rdefinp	Digital inputs definition	Define the active state of the input: if Bit = 0, active high, if Bit = 1, active low (For the bit mapping, see Rinp table)																																																																		
Rfilinp	Inputs digital filter	Set the digital filter time (expressed in ms) of the digital inputs bank																																																																		
Renfinp	Digital filter enabling mask	Permit to define on which inputs the digital filter must be activated, by raising the bit of the desired input (Bit = 1 → Filter enabled) (For the bit mapping, see Rinp table)																																																																		
Rmeminp	Inputs state memory	Store the (active) state of each service input; the bit of the input remains high until the reset of the same by the user. (For the bit mapping, see Rinp table)																																																																		
Rfuni0 Rfuni1 Rfuni2 Rfuni3 Rfuni4 Rfuni5 Rfuni6 Rfuni7	Functions associated with the inputs	<p>For each input, there is a register that indicates the function of the same; to associate the input with a specific function, it is sufficient to write the function code inside the desired function register (eg. to associate the input 0 with the “Enable drive” function, → Rfuni0 = 1). The available functions are:</p> <table border="1"> <thead> <tr> <th>Func. Code</th> <th>Description</th> <th>Active on</th> <th>Func. Code</th> <th>Description</th> <th>Active on</th> </tr> </thead> <tbody> <tr> <td>0</td> <td>None</td> <td>-</td> <td>10</td> <td>B3 Task select.</td> <td>State</td> </tr> <tr> <td>1</td> <td>Enable drive</td> <td>State</td> <td>11</td> <td>B4 Task select.</td> <td>State</td> </tr> <tr> <td>2</td> <td>JOG CW</td> <td>↑ edge</td> <td>12</td> <td>B5 Task select.</td> <td>State</td> </tr> <tr> <td>3</td> <td>JOG CCW</td> <td>↑ edge</td> <td>13</td> <td>B6 Task select.</td> <td>State</td> </tr> <tr> <td>4</td> <td>GO target</td> <td>↑ edge</td> <td>14</td> <td>Start Task</td> <td>↑ edge</td> </tr> <tr> <td>5</td> <td>GOR target</td> <td>↑ edge</td> <td>15</td> <td>Alarms reset</td> <td>↑ edge</td> </tr> <tr> <td>6</td> <td>Stsr Home</td> <td>↑ edge</td> <td>16</td> <td>Realign quota</td> <td>↑ edge</td> </tr> <tr> <td>7</td> <td>B0 Task select.</td> <td>State</td> <td>17</td> <td>Reduce current</td> <td>State</td> </tr> <tr> <td>8</td> <td>B1 Task select.</td> <td>State</td> <td>18</td> <td>Abort</td> <td>↑ edge</td> </tr> <tr> <td>9</td> <td>B2 Task select.</td> <td>State</td> <td>19</td> <td>Stop</td> <td>↑ edge</td> </tr> </tbody> </table>	Func. Code	Description	Active on	Func. Code	Description	Active on	0	None	-	10	B3 Task select.	State	1	Enable drive	State	11	B4 Task select.	State	2	JOG CW	↑ edge	12	B5 Task select.	State	3	JOG CCW	↑ edge	13	B6 Task select.	State	4	GO target	↑ edge	14	Start Task	↑ edge	5	GOR target	↑ edge	15	Alarms reset	↑ edge	6	Stsr Home	↑ edge	16	Realign quota	↑ edge	7	B0 Task select.	State	17	Reduce current	State	8	B1 Task select.	State	18	Abort	↑ edge	9	B2 Task select.	State	19	Stop	↑ edge
Func. Code	Description	Active on	Func. Code	Description	Active on																																																															
0	None	-	10	B3 Task select.	State																																																															
1	Enable drive	State	11	B4 Task select.	State																																																															
2	JOG CW	↑ edge	12	B5 Task select.	State																																																															
3	JOG CCW	↑ edge	13	B6 Task select.	State																																																															
4	GO target	↑ edge	14	Start Task	↑ edge																																																															
5	GOR target	↑ edge	15	Alarms reset	↑ edge																																																															
6	Stsr Home	↑ edge	16	Realign quota	↑ edge																																																															
7	B0 Task select.	State	17	Reduce current	State																																																															
8	B1 Task select.	State	18	Abort	↑ edge																																																															
9	B2 Task select.	State	19	Stop	↑ edge																																																															



CAUTION!!! On the falling edge of the movement commands (JOG CW, JOG CCW, GO, GOR, Start Home and Start Task), a Stop command is automatically generated, in order to interrupt the started procedure.



CAUTION!!! Two inputs share the same terminals with the digital outputs 2-3, so if one of these signals are used, the relative output (or vice versa) cannot be used.

DIGITAL OUTPUTS

The SMD1204 provides up to 8 lines of general purpose PNP digital outputs (5-24Vdc), protected against overloads and short-circuits; such outputs can be associated with specific functions.

The outputs are associated with 3 registers, which permit to know their state and to configure the functioning:

Register	Name	Description																		
Rout	Output state	<p>Indicate or set the state of each output (read and write)</p> <table border="1"> <thead> <tr> <th>Bit</th> <th>Description</th> </tr> </thead> <tbody> <tr> <td>0</td> <td>Output 0</td> </tr> <tr> <td>1</td> <td>Output 1</td> </tr> <tr> <td>2</td> <td>Output 2</td> </tr> <tr> <td>3</td> <td>Output 3</td> </tr> <tr> <td>4</td> <td>Output 4</td> </tr> <tr> <td>5</td> <td>Output 5</td> </tr> <tr> <td>6</td> <td>Output 6</td> </tr> <tr> <td>7</td> <td>Output 7</td> </tr> </tbody> </table>	Bit	Description	0	Output 0	1	Output 1	2	Output 2	3	Output 3	4	Output 4	5	Output 5	6	Output 6	7	Output 7
Bit	Description																			
0	Output 0																			
1	Output 1																			
2	Output 2																			
3	Output 3																			
4	Output 4																			
5	Output 5																			
6	Output 6																			
7	Output 7																			

Register	Name	Description																		
Rdefout	Digital outputs definition	Define the active state of the output: if Bit = 0, active high, if Bit = 1, active low (For the bit mapping, see Rout table)																		
Rfuno0 Rfuno1 Rfuno2 Rfuno3 Rfuno4 Rfuno5 Rfuno6 Rfuno7	Functions associated with the outputs	<p>For each output, there is a register that indicates the function of the same; to associate the input with a specific function, it is sufficient to write the function code inside the desired function register (eg. to associate the output 0 with the "Drive enabled" function, → Rfuno0 = 1). The available functions are:</p> <table border="1"> <thead> <tr> <th>Func. Code</th> <th>Description</th> </tr> </thead> <tbody> <tr> <td>0</td> <td>None</td> </tr> <tr> <td>1</td> <td>Drive enabled</td> </tr> <tr> <td>2</td> <td>Alarm</td> </tr> <tr> <td>3</td> <td>Synchronized axis</td> </tr> <tr> <td>4</td> <td>Axis in movement</td> </tr> <tr> <td>5</td> <td>Task in progress</td> </tr> <tr> <td>6</td> <td>I2T alarm</td> </tr> <tr> <td>7</td> <td>Axis in position</td> </tr> </tbody> </table>	Func. Code	Description	0	None	1	Drive enabled	2	Alarm	3	Synchronized axis	4	Axis in movement	5	Task in progress	6	I2T alarm	7	Axis in position
Func. Code	Description																			
0	None																			
1	Drive enabled																			
2	Alarm																			
3	Synchronized axis																			
4	Axis in movement																			
5	Task in progress																			
6	I2T alarm																			
7	Axis in position																			

ANALOG INPUTS

The SMD1204 provides up to 3 precision analog inputs for general purpose (0-10V_{DC} at 12-bit); these inputs can be associated with specific functions.

The inputs are associated with 6 registers, which permit to know their state and to configure the functioning:

Register	Name	Description																				
Rainp Rainp1 Rainp2	Digitized value of the analog inputs	Show the digitized voltage value applied to the terminal of the analog input. The A/D converter uses a 12-bit scale for the conversion of the signal (10V = 4096).																				
Rdefainp Rdefainp1 Rdefainp2	Analog input definition	<p>The analog input can be used for the conditioning of some values inside the drive; this register sets which value is conditioned by the analog input. The value of Rainp is copied inside the associated register (the associated occurs by copying the function code in the register Rdefainp):</p> <table border="1"> <thead> <tr> <th>Func. Code</th> <th>Description</th> </tr> </thead> <tbody> <tr> <td>137</td> <td>None</td> </tr> <tr> <td>20</td> <td>Event stop delay (ESTOP)</td> </tr> <tr> <td>24</td> <td>Stop delay</td> </tr> <tr> <td>63</td> <td>Velocity</td> </tr> <tr> <td>67</td> <td>Acceleration</td> </tr> <tr> <td>70</td> <td>Deceleration</td> </tr> <tr> <td>83</td> <td>Homing velocity</td> </tr> <tr> <td>87</td> <td>Homing acceleration</td> </tr> <tr> <td>210</td> <td>Limit of current</td> </tr> </tbody> </table>	Func. Code	Description	137	None	20	Event stop delay (ESTOP)	24	Stop delay	63	Velocity	67	Acceleration	70	Deceleration	83	Homing velocity	87	Homing acceleration	210	Limit of current
Func. Code	Description																					
137	None																					
20	Event stop delay (ESTOP)																					
24	Stop delay																					
63	Velocity																					
67	Acceleration																					
70	Deceleration																					
83	Homing velocity																					
87	Homing acceleration																					
210	Limit of current																					
Rmulainp Rmulainp1 Rmulainp2	Analog input multiplier	Set the multiplication constant of the analog input. Along with the divider, the offset and the dead-band, permits to condition the value of the register Rainp, in order to adapt to the characteristics of the analog signal applied or to the value which must be controlled																				
Rdivainp Rdivainp1 Rdivainp2	Analog input divider	Set the division constant of the analog input. Along with the multiplier, the offset and the dead-band, permits to condition the value of the register Rainp, in order to adapt to the characteristics of the analog signal applied or to the value which must be controlled																				

Register	Name	Description
Roffsanainp Roffsanainp1 Roffsanainp2	Analog input offset	Set the analog input offset. Along with the multiplier, the divider and the dead-band, permits to condition the value of the register Ranainp, in order to adapt to the characteristics of the analog signal applied or to the value which must be controlled
Rdeadanainp Rdeadanainp1 Rdeadanainp2	Analog input dead-band	Set the analog input dead-band. Along with the multiplier, the divider and the offset, permits to condition the value of the register Ranainp, in order to adapt to the characteristics of the analog signal applied or to the value which must be controlled

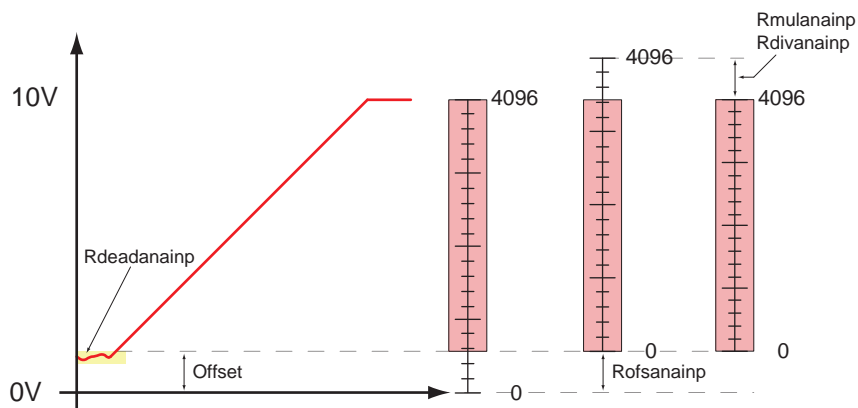

As shown above, it is possible: to create a dead band (yellow zone) in order to eliminate disturbances of the reference in proximity of the minimum value; to shift the analog register in order to let the 0 value coincide with the reference minimum value (Offset); to compress or to expand the scale in order to let the value 4096 (full scale) coincide with the maximum reference value (Rmulanainp and Rdivanainp).

In this case, the value of the analog register will be:

$$R_{ANAINP} = (V_{IN_DIG} - R_{OFFSET}) \times \frac{K_{MUL}}{K_{DIV}} \quad \text{se } R_{ANAINP} < \text{Dead-Band} \quad R_{ANAINP} = 0$$

V_{IN_DIG} = Digitized input voltage (0..10V_{DC} = 0..4096)

ANALOG OUTPUT

The SMD1204 provides 1 analog output for general purpose (0-10V_{DC} at 10-bit); these output can be associated with specific functions.

The output is associated with 5 registers, which permit to know its state and to configure the functioning:

Register	Name	Description														
Ranaout	Digitized value of the analog output	Show the digitized voltage value applied to the terminal of the analog output. The A/D converter uses a 10-bit scale for the conversion of the signal (1024 = 10V).														
Rdefanaout	Analog input definition	The analog output can be used to show some values inside the drive; this register sets which value is shown by the analog output. The value of the associated register is copied in Ranaout (the association occurs by copying the function code in the register Rdefanaout): <table border="1" style="width: 100%; border-collapse: collapse;"> <thead> <tr> <th>Func. Code</th> <th>Description</th> </tr> </thead> <tbody> <tr> <td>143</td> <td>None</td> </tr> <tr> <td>75</td> <td>Actual velocity</td> </tr> <tr> <td>378</td> <td>Actual current</td> </tr> <tr> <td>0</td> <td>Actual position</td> </tr> <tr> <td>153</td> <td>Auxiliary encoder quota</td> </tr> <tr> <td>151</td> <td>Motor encoder quota</td> </tr> </tbody> </table>	Func. Code	Description	143	None	75	Actual velocity	378	Actual current	0	Actual position	153	Auxiliary encoder quota	151	Motor encoder quota
Func. Code	Description															
143	None															
75	Actual velocity															
378	Actual current															
0	Actual position															
153	Auxiliary encoder quota															
151	Motor encoder quota															

Register	Name	Description
Rmulanaout	Analog output multiplier	Set the multiplication constant of the analog output. Along with the divider and the offset, permits to condition the value of the register Ranaout, in order to adapt to the characteristics of the value which must be shown.
Rdivanaout	Analog output divider	Set the division constant of the analog output. Along with the multiplier and the offset, permits to condition the value of the register Ranaout, in order to adapt to the characteristics of the value which must be shown.
Roffsanaout	Offset uscita analogica	Offset da sommare al valore da impostare nell'uscita analogica. Along with the multiplier and the divider, permits to condition the value of the register Ranaout, in order to adapt to the characteristics of the value which must be shown.

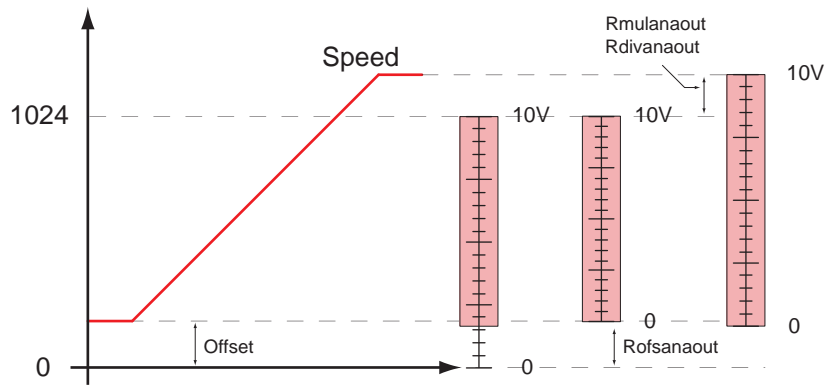

As shown above, it is possible to act on the offset register and on the multiplication and division constant in order to shift the analog register, with the purpose to let the value 0 coincide to the minimum reference value (Offset) and to compress or dilate the scale with the purpose to let the value 1024 coincide to the maximum reference value (Rmulanaout and Rdivanaout).

In this case, the value of the analog register will be:

$$V_{\text{OUT_DIG}} = (R_{\text{ANAOUT}} - R_{\text{OFFSET}}) \times \frac{K_{\text{MUL}}}{K_{\text{DIV}}}$$

$V_{\text{OUT_DIG}}$ = Digitized input voltage (0..1024 = 0..10V_{DC})

AUXILIARY ENCODER PARAMETERS

GENERAL CHARACTERISTICS

This set of parameters permits to define the characteristics and the operating mode of the auxiliary encoder.

The auxiliary encoder inputs can be used to generate electronic cams, followings, to control the drive in step/direction mode, or simply as digital inputs.

RESOLUTION

Indicate the number of pulses per revolution of the external encoder:

Register	Name	Description
Rextencpuls	Auxiliary encoder resolution	Set the number of pulses per revolution of the auxiliary encoder

This parameter is necessary to detect the velocity of the auxiliary encoder.



CAUTION!!! Entering wrong parameters causes a wrong reading of the auxiliary encoder velocity.

OPERATION MODE

Indicate the operation mode of the external encoder:

Register	Name	Description
Rextencmode	Auxiliary encoder operation mode	Define the operation mode of the input:
		Value Description
		0 Quadrature forward
		1 Quadrature backward
		2 Step-IN and direction x1 (Rising edge)
3 Step-IN and direction x2 (Both edges)		

The auxiliary encoder input can work both as input in quadrature, and as input in frequency and direction.

In the first case, the increase or decrease of the auxiliary encoder quota (Rextenc) occurs by combining two 90° phase-shifted squared waveforms. The sequence in which they are generated defines the counting direction and the validity of the count itself.

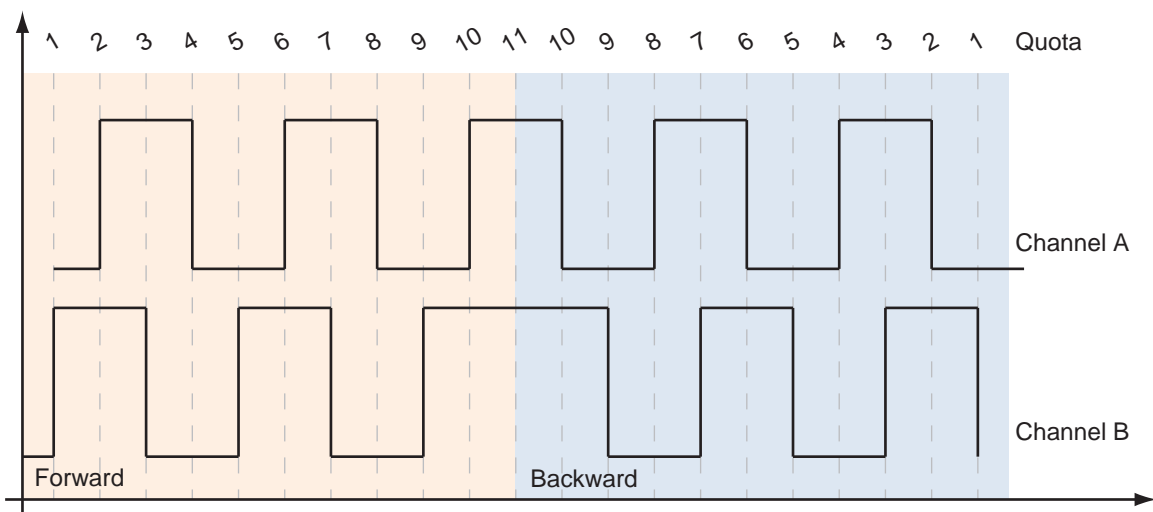

It is possible to define if the encoder quota must increase when the encoder turns clockwise or counter-clockwise.

Working in frequency and direction, instead, the channel A becomes the input in frequency, while the channel B defines the counting direction (modes 2 and 3).

In mode 2, the encoder quota is incremented (or decremented, depending on the value in the direction input) on the rising edge of the signal in input; in mode 3, the increase (or decrease) occurs both on the rising edge and on the falling edge of the signal.

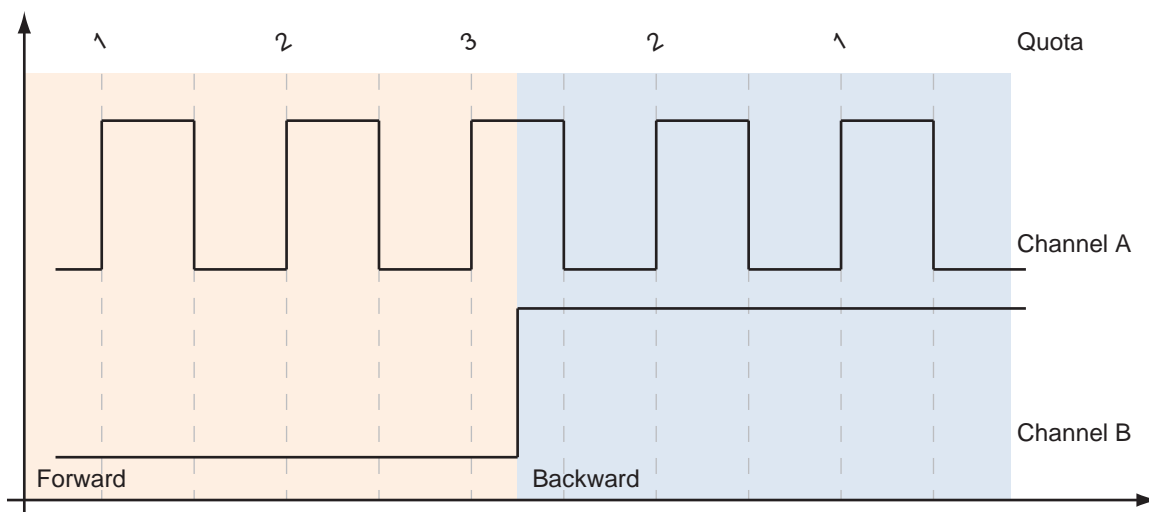

Step-IN and direction x1 (Rising edge)

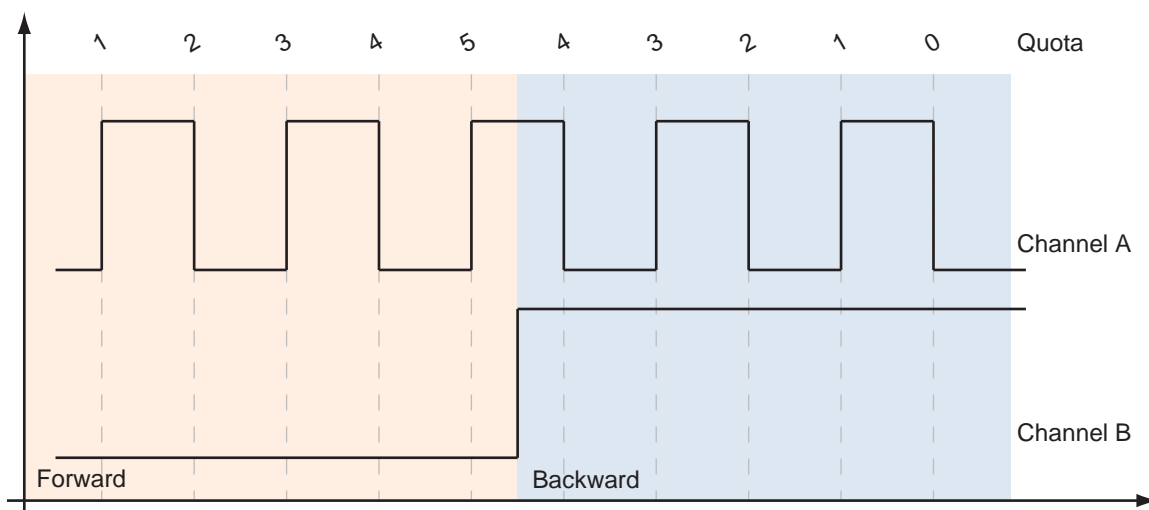

Step-IN and direction x2 (Both edges)

CONDITIONING OF THE VELOCITY READING

The VectorStep drives permit to detect the rotation velocity of the external encoder, conditioning its value. To use this feature, it is necessary to define some parameters, as:

Register	Name	Description
Rextencsmp	Sample time	Set the time with which the encoder input is sampled, for the detection of the velocity. It is expressed in ms.
Rextencvelmul	Encoder velocity multiplier	Set the multiplication constant of the detected velocity value.
Rextencveldiv	Encoder velocity divider	Set the division constant of the detected velocity value.

The rotation speed of the encoder results from the calculation below:

$$V_{ENC} = \frac{\Delta_{QUOTA}}{T_{SAMPLE}} \times \frac{K_{MUL}}{K_{DIV}}$$

Where:

- V_{ENC} = External encoder velocity
- Δ_{QUOTA} = Quota increase
- T_{SAMPLE} = Sample time
- K_{MUL} = Multiplication constant
- K_{DIV} = Division constant

ALARM PARAMETERS

GENERAL CHARACTERISTICS

The VectorStep drives are able to detect and manage different fault conditions, like: overvoltage, undervoltage, hardware or software overcurrent, overtemperature, positioning or phasing following errors, I²T, digital outputs overload, phases wiring errors.

When a fault occurs, the drive disables the power stage, store the type of fault in the internal buffer and notices the anomaly on the STS LED (Red ON); the power stage will be re-enabled after the fault cause is removed, the alarm is reset and the enable command is sent.

The non-destructive alarms (undervoltage, following and I²T) can be masked and made inactive.

The alarm interface is able to recognise pre-alarm thresholds (warnings) which permit to acknowledge anomalous or critic conditions before an hardware fault occurs.

ALARMS CONFIGURATION

All the alarms managed by the drive have configurable thresholds, which permit to modify the sensitivity and the intervention points of the same.

Register	Description	Value		UM	Mask
		Min.	Max.		
Rtempalm	Overtemperature alarm threshold	25	120	°C	No
Rtensmax	Overvoltage alarm threshold	30	80	V	No
Rtensmin	Undervoltage alarm threshold	20	60	V	Yes
Rcurmax	Overcurrent alarm threshold	0	15000	mA	No
Rflwmax	Following error alarm threshold	-2 ³¹	+2 ³¹	counts	Yes
Ri2tmax	I ² T alarm threshold	0	+2 ³²	mA ² ms	Yes
Rdeadpos	Position dead-band for positioning alarm	0	65535	counts	Yes
Rposalmtime	Time before positioning alarm in Closed Loop.	0	65535	ms	Yes
Rpostimeout	Time for positioning Time-out	0	65535	ms	Yes
Rflwencerr	Maximum counting error between motor encoder counter and motor steps	0	+2 ³¹	counts	Yes

The non-destructive alarms can be masked by writing 1 on the relative bit in the register Rmaskalm:

Register	Nome	Description	
Rmaskalm	<i>Alarms mask</i>	Permit to disable non-destructive alarms	
		Bit	Description
		[0..1]	Reserved
		2	I ² T alarm disabling
		3	Position alarm disabling
		4	Following error alarm disabling
		[5..7]	Reserved
		8	Undervoltage alarm disabling
		12	Positioning timeout alarm disabling
[9..15]	Reserved		

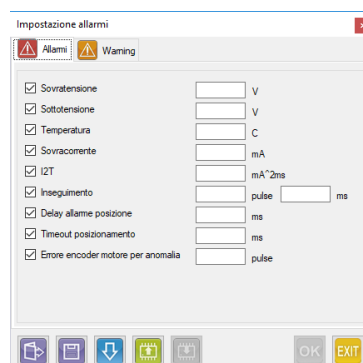

WARNING CONFIGURATION

Like the alarms, also the warnings managed by the drive have configurable thresholds, which permit to modify the sensitivity and the intervention point of the same.

The occurrence of a warning has no effects on the execution of a command or program, but has the purpose to notice a potentially critical situation to the user.

Register	Description	Value		UM	Mask
		Min.	Max.		
Rtempwrn	Overtemperature warning threshold	25	120	°C	No
Rovvwrn	Overvoltage warning threshold	30	80	V	No
Runvwrn	Undervoltage warning threshold	20	60	V	Yes
Rovcwrn	Overcurrent warning threshold	0	15000	mA	No
Rflwvrn	Following error warning threshold	-2 ³¹	+2 ³¹	counts	Yes
Rwrni2t	I ² T warning threshold	0	+2 ³²	mA ² ms	Yes
Rposwrntime	Time before positioning warning in Closed Loop.	0	32000	ms	Yes
Rpostimeoutwrn	Time for positioning Time-out warning	0	65535	ms	Yes

The warnings can be masked by writing 1 on the relative bit in the register Rmaskwrn:

Register	Name	Description																		
Rmaskwrn	<i>Warnings mask</i>	Permit to disable alarms																		
		<table border="1"> <thead> <tr> <th>Bit</th> <th>Description</th> </tr> </thead> <tbody> <tr> <td>[0..1]</td> <td>Reserved</td> </tr> <tr> <td>2</td> <td>I²T warning disabling</td> </tr> <tr> <td>3</td> <td>Position warning disabling</td> </tr> <tr> <td>4</td> <td>Following error warning disabling</td> </tr> <tr> <td>[5..7]</td> <td>Reserved</td> </tr> <tr> <td>8</td> <td>Undervoltage warning disabling</td> </tr> <tr> <td>12</td> <td>Positioning timeout warning disabling</td> </tr> <tr> <td>[9..15]</td> <td>Reserved</td> </tr> </tbody> </table>	Bit	Description	[0..1]	Reserved	2	I ² T warning disabling	3	Position warning disabling	4	Following error warning disabling	[5..7]	Reserved	8	Undervoltage warning disabling	12	Positioning timeout warning disabling	[9..15]	Reserved
		Bit	Description																	
		[0..1]	Reserved																	
		2	I ² T warning disabling																	
		3	Position warning disabling																	
		4	Following error warning disabling																	
		[5..7]	Reserved																	
		8	Undervoltage warning disabling																	
12	Positioning timeout warning disabling																			
[9..15]	Reserved																			

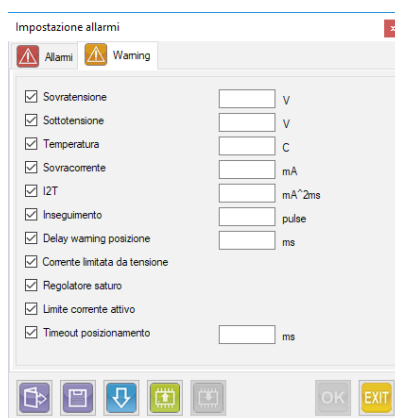

ALARMS HISTORY

The SMD1204 is able to store and hold in memory (until the shut-down) up to 8 alarms. The alarms history consists of a 8 positions buffer, where the last occurred alarm codes are saved. In case an higher number of alarms occurs, the active alarm will overwrite the oldest saved alarm.

Register	Name	Description								
Rbufalm0	<i>Alarm buffer 0</i>	Position 0 of the alarms history buffer								
Rbufalm1	<i>Alarm buffer 1</i>	Position 1 of the alarms history buffer								
Rbufalm2	<i>Alarm buffer 2</i>	Position 2 of the alarms history buffer								
Rbufalm3	<i>Alarm buffer 3</i>	Position 3 of the alarms history buffer								
Rbufalm4	<i>Alarm buffer 4</i>	Position 4 of the alarms history buffer								
Rbufalm5	<i>Alarm buffer 5</i>	Position 5 of the alarms history buffer								
Rbufalm6	<i>Alarm buffer 6</i>	Position 6 of the alarms history buffer								
Rbufalm7	<i>Alarm buffer 7</i>	Position 7 of the alarms history buffer								
Ralmcont	<i>Alarms counter</i>	Contain the number of faults occurred in the drive. At the shut-down of the drive, the counter is automatically saved. To reset the counter, act on the register Ralmack.								
Ralmack	<i>Alarms acknowledge</i>	<p>Permit to delete the alarms history buffer and to reset the absolute counter:</p> <table border="1"> <thead> <tr> <th>Bit</th> <th>Description</th> </tr> </thead> <tbody> <tr> <td>0</td> <td>Alarms acknowledge</td> </tr> <tr> <td>1</td> <td>Alarms counter reset</td> </tr> <tr> <td>[2..15]</td> <td>Reserved</td> </tr> </tbody> </table> <p>Each time the bit 0 is activated (Alarms acknowledge) the drive deletes the last position of the of the alarms history buffer. If the buffer is full, in order to emptying it, it is necessary to send 8 acknowledges (starting from position 7).</p>	Bit	Description	0	Alarms acknowledge	1	Alarms counter reset	[2..15]	Reserved
Bit	Description									
0	Alarms acknowledge									
1	Alarms counter reset									
[2..15]	Reserved									

COMMUNICATION PARAMETERS

GENERAL CHARACTERISTICS

The drives SMD1204 can communicate with the external (PLC, HMI, Host computer etc.) by using several fieldbus: Modbus RTU (SMD1204xxM), CANopen (SMD1204xxC), Profibus DP (SMD1204xxP), Modbus TCP/IP (SMD1204xxE), EtherCAT (SMD1204xxT) and Profinet (SMD1204xxN).

Each of these transmission channel can be configured in order to adapt its characteristics to the application field. The only common parameter is the physical address of the node, defined by the address setting rotary switch (except for Ethernet protocols)

All the fieldbus permit to access to any internal resource of the drive, from the process data to the configuration.

MODBUS RTU PARAMETERS (SMD1204xxM)

The Modbus RTU communication channel is the default communication for the VectorStep drives. In fact it is used for the configuration and the programming of the drives.

The serial communication uses two serial transmission interfaces:

- EIA RS-232
- EIA RS-485

The first one permits the point-to-point connection, namely the connection between two devices for the direct exchange of the data. It can never exist a third party in a RS-232 network.

The RS-485, instead, in addition to the point-to-point connection, permits the multi-point connection, namely the simultaneous connection of more devices (up to 32) on the same communication network. In a multi-point network it is of fundamental importance that each device is uniquely defined by an address.

The SMD1204 permits to define the communication parameters of both the interfaces. The parameters provided to the user are the following:

Register	Name	Description																					
Rserbaud	<i>Serial communication speed</i>	Set the communication speed of the port: <table border="1"> <thead> <tr> <th>Value</th> <th>Communication speed (Baud-rate)</th> <th>Value</th> <th>Communication speed (Baud-rate)</th> </tr> </thead> <tbody> <tr> <td>0</td> <td>1200</td> <td>4</td> <td>19200</td> </tr> <tr> <td>1</td> <td>2400</td> <td>5</td> <td>38400</td> </tr> <tr> <td>2</td> <td>4800</td> <td>6</td> <td>57600</td> </tr> <tr> <td>3</td> <td>9600</td> <td>7</td> <td>115200</td> </tr> </tbody> </table>	Value	Communication speed (Baud-rate)	Value	Communication speed (Baud-rate)	0	1200	4	19200	1	2400	5	38400	2	4800	6	57600	3	9600	7	115200	
Value	Communication speed (Baud-rate)	Value	Communication speed (Baud-rate)																				
0	1200	4	19200																				
1	2400	5	38400																				
2	4800	6	57600																				
3	9600	7	115200																				
Rserpar	<i>Serial port parameters</i>	Set the communication parameters of the port (Parity and Stop Bit Nr.): <table border="1"> <thead> <tr> <th>Value</th> <th>Parity</th> <th>Stop Bit</th> </tr> </thead> <tbody> <tr> <td>0</td> <td>None</td> <td>1</td> </tr> <tr> <td>1</td> <td>Even</td> <td>1</td> </tr> <tr> <td>2</td> <td>Odd</td> <td>1</td> </tr> <tr> <td>3</td> <td>None</td> <td>2</td> </tr> <tr> <td>4</td> <td>Even</td> <td>2</td> </tr> <tr> <td>5</td> <td>Odd</td> <td>2</td> </tr> </tbody> </table>	Value	Parity	Stop Bit	0	None	1	1	Even	1	2	Odd	1	3	None	2	4	Even	2	5	Odd	2
Value	Parity	Stop Bit																					
0	None	1																					
1	Even	1																					
2	Odd	1																					
3	None	2																					
4	Even	2																					
5	Odd	2																					
Rserdly	<i>Reply delay</i>	Set the reply delay of the drive. It is particularly useful in case of use of Auto-switch RS-485 conversion interfaces, in order to adapt the reply times of the drive to the switch times of the interface.																					
Rseraddr	<i>Serial address offset</i>	This value is added to the value of the rotary switch, to set the communication addresses higher than 89 (89 is the highest value configurable through rotary switch).																					
Rintmot	<i>32bit data format</i>	With double word data exchange (32bit), this parameter defines the order of sending and receiving of the double word. <table border="1"> <thead> <tr> <th>Value</th> <th>Parity</th> <th>Stop Bit</th> <th></th> </tr> </thead> <tbody> <tr> <td>0</td> <td>Intel</td> <td>Little Endian</td> <td>LSB <-> MSB</td> </tr> <tr> <td>1</td> <td>Motorola</td> <td>Big Endian</td> <td>MSB <-> LSB</td> </tr> </tbody> </table>	Value	Parity	Stop Bit		0	Intel	Little Endian	LSB <-> MSB	1	Motorola	Big Endian	MSB <-> LSB									
Value	Parity	Stop Bit																					
0	Intel	Little Endian	LSB <-> MSB																				
1	Motorola	Big Endian	MSB <-> LSB																				

As an alternative in writing each register, it is possible to set the parameters with StepContrl, by accessing “Communication parametrs”

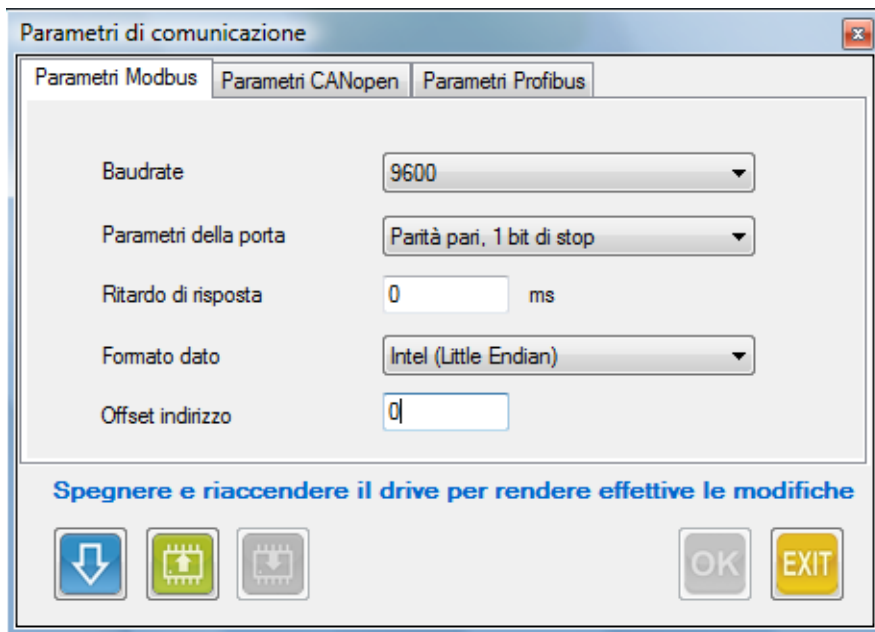

CANOPEN PARAMETERS (SMD1204xxC)

The CANopen parameters permit to set the communication speed of the bus, and, optionally, the software offset to be added to the hardware address.

Register	Name	Description																				
Rcanbaud	<i>CANopen bus communication speed</i>	Set the communication speed of the CANopen bus:																				
		<table border="1"> <thead> <tr> <th>Value</th> <th>Communication speed (Baud-rate)</th> <th>Value</th> <th>Communication speed (Baud-rate)</th> </tr> </thead> <tbody> <tr> <td>0</td> <td>10Kb</td> <td>4</td> <td>250Kb</td> </tr> <tr> <td>1</td> <td>20Kb</td> <td>5</td> <td>500Kb</td> </tr> <tr> <td>2</td> <td>50Kb</td> <td>6</td> <td>800Kb</td> </tr> <tr> <td>3</td> <td>125Kb</td> <td>7</td> <td>1000Kb</td> </tr> </tbody> </table>	Value	Communication speed (Baud-rate)	Value	Communication speed (Baud-rate)	0	10Kb	4	250Kb	1	20Kb	5	500Kb	2	50Kb	6	800Kb	3	125Kb	7	1000Kb
		Value	Communication speed (Baud-rate)	Value	Communication speed (Baud-rate)																	
		0	10Kb	4	250Kb																	
		1	20Kb	5	500Kb																	
2	50Kb	6	800Kb																			
3	125Kb	7	1000Kb																			
Rcanaddr	<i>CAN address offset</i>	This value is added to the value of the rotary switch, to set the communication addresses higher than 89 (89 is the highest value configurable through rotary switch).																				

As an alternative in writing each register, it is possible to set the parameters with StepContrl, by accessing “Communication parametrs”

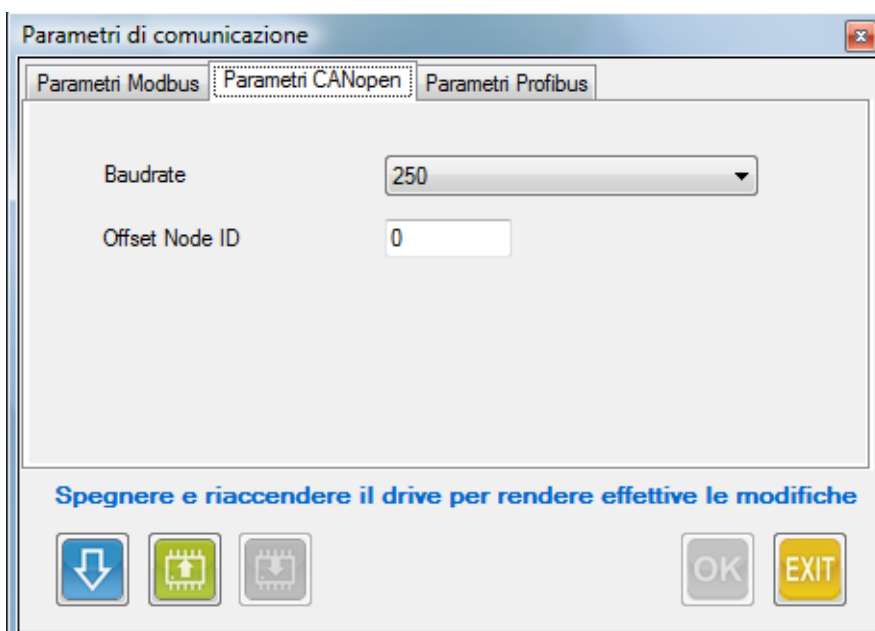

PROFIBUS PARAMETERS (SMD1204xxP)

The Profibus parameters permit to set the communication speed of the bus, and, optionally, the software offset to be added to the hardware address.

Register	Name	Description																												
Rprofibaud	<i>Profibus DP communication speed</i>	Set the communication speed of the Profibus:																												
		<table border="1"> <thead> <tr> <th>Value</th> <th>Communication speed (Baud-rate)</th> <th>Value</th> <th>Communication speed (Baud-rate)</th> </tr> </thead> <tbody> <tr> <td>0</td> <td>Autobitrate</td> <td>6</td> <td>187,5KB</td> </tr> <tr> <td>1</td> <td>9,6KB</td> <td>7</td> <td>500KB</td> </tr> <tr> <td>2</td> <td>19,2KB</td> <td>8</td> <td>1500KB</td> </tr> <tr> <td>3</td> <td>31,25KB</td> <td>9</td> <td>3000KB</td> </tr> <tr> <td>4</td> <td>45,45KB</td> <td>10</td> <td>6000KB</td> </tr> <tr> <td>5</td> <td>93,75KB</td> <td>11</td> <td>12000KB</td> </tr> </tbody> </table>	Value	Communication speed (Baud-rate)	Value	Communication speed (Baud-rate)	0	Autobitrate	6	187,5KB	1	9,6KB	7	500KB	2	19,2KB	8	1500KB	3	31,25KB	9	3000KB	4	45,45KB	10	6000KB	5	93,75KB	11	12000KB
		Value	Communication speed (Baud-rate)	Value	Communication speed (Baud-rate)																									
		0	Autobitrate	6	187,5KB																									
		1	9,6KB	7	500KB																									
		2	19,2KB	8	1500KB																									
		3	31,25KB	9	3000KB																									
4	45,45KB	10	6000KB																											
5	93,75KB	11	12000KB																											
Rprofiaddr	<i>Profibus DP address offset</i>	This value is added to the value of the rotary switch, to set the communication addresses higher than 89 (89 is the highest value configurable through rotary switch).																												

As an alternative in writing each register, it is possible to set the parameters with StepContrl, by accessing “Communication parameters”

MODBUS TCP/IP PARAMETERS (SMD1204xxE)

The Modbus TCP parameters permit to set the IP address, the Ethernet Subnet, the Gateway address, the Modbus TCP port, the data format and the MAC address.

Register	Name	Description
Rethlocipaddr32	<i>Byte 3 - Byte 2 Ethernet local IP address</i>	Set the Byte 3 and the Byte 2 of the Ethernet local IP address
Rethlocipaddr10	<i>Byte 1 - Byte 0 Ethernet local IP address</i>	Set the Byte 1 and the Byte 0 of the Ethernet local IP address
Rethsubnet32	<i>Byte 3 - Byte 2 Ethernet Subnet</i>	Set the Byte 3 and the Byte 2 of the Ethernet Subnet
Rethsubnet10	<i>Byte 1 - Byte 0 Ethernet Subnet</i>	Set the Byte 1 and the Byte 0 of the Ethernet Subnet
Rethgwaddr32	<i>Byte 3 - Byte 2 Ethernet Gateway address</i>	Set the Byte 3 and the Byte 2 of the Ethernet Gateway
Rethgwaddr10	<i>Byte 1 - Byte 0 Ethernet Gateway address</i>	Set the Byte 1 and the Byte 0 of the Ethernet Gateway
Rethmacaddr054	<i>Byte 5 - Byte 4 MAC address 0 ethernet</i>	Set the Byte 5 and the Byte 4 of the MAC Address
Rethmacaddr032	<i>Byte 3 - Byte 2 MAC address 0 ethernet</i>	Set the Byte 3 and the Byte 2 of the MAC Address
Rethmacaddr010	<i>Byte 1 - Byte 0 MAC address 0 ethernet</i>	Set the Byte 1 and the Byte 0 of the MAC Address

As an alternative in writing each register, it is possible to set the parameters with StepContrl, by accessing “Communication parameters”

ETHERCAT PARAMETERS (SMD1204xxT)

The EtherCAT parameters permit to set the EtherCAT ID .

Register	Name	Description
Rethercatid	<i>Explicite board ID Ethercat</i>	Manual setting of the EtherCAT ID

As an alternative in writing each register, it is possible to set the parameters with StepControl, by accessing “Communication parameters”



CAUTION: If the mode 8 of the drive is in use (it is possible to verify it with StepControl, register “Rcanmodeoperation”), it is necessary to set the maximum step resolution, in order to have a smooth and noiseless movement.

PROFINET PARAMETERS (SMD1204xIN)

The Profinet node-ID and the IP address can setting directly by the Profinet master

As an alternative to write the single register, it is possible to set the parameters by accessing the “Communication parameters” section in the software StepControl

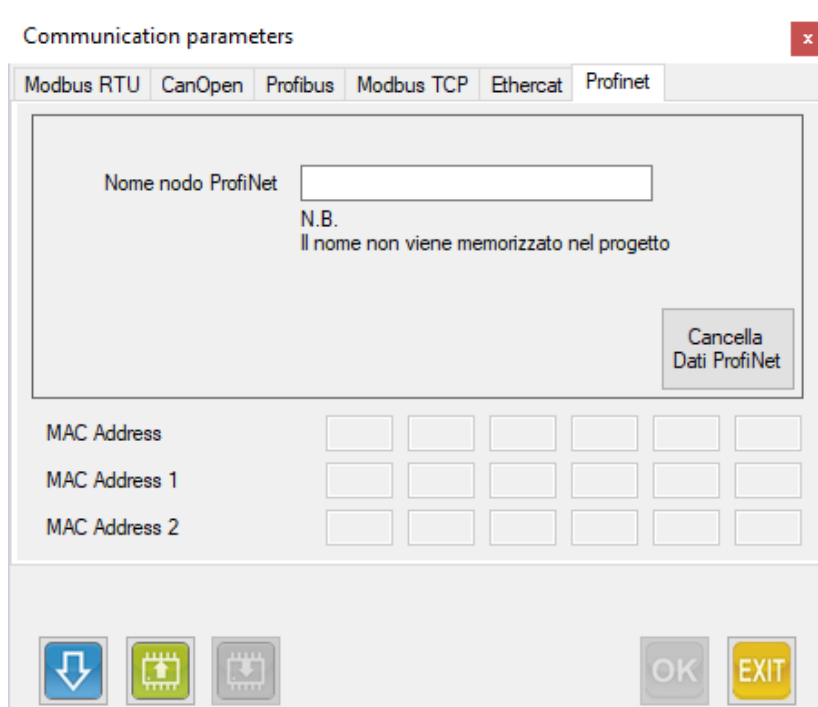

HARDWARE PARAMETERS

GENERAL CHARACTERISTICS

The hardware parameters permit to configure the default rotation direction of the motor and the motor encoder, in order to adapt to existing mechanical solutions.

ROTATION DIRECTION OF THE MOTOR

Following the wiring instructions of the motor, the same rotates clockwise (CW) by default.

The SMD1204 permits to modify the rotation direction, by acting on the bit 2 of the register "Hardware config":

Registro	Nome	Descrizione								
Rhwconfig	<i>Hardware configuration</i>	Imposta il verso di rotazione predefinito del motore								
		<table border="1"><thead><tr><th>Bit</th><th>Stato</th><th>Descrizione</th></tr></thead><tbody><tr><td rowspan="2">2</td><td>L</td><td>Verso di rotazione standard (CW)</td></tr><tr><td>H</td><td>Verso di rotazione invertito (CCW)</td></tr></tbody></table>	Bit	Stato	Descrizione	2	L	Verso di rotazione standard (CW)	H	Verso di rotazione invertito (CCW)
		Bit	Stato	Descrizione						
2	L	Verso di rotazione standard (CW)								
	H	Verso di rotazione invertito (CCW)								

ROTATION DIRECTION OF THE MOTOR ENCODER

Following the wiring instructions of the motor encoder, the increments occur by rotating clockwise (CW).

The SMD1204 permits to modify the rotation direction, by acting on the bit 1 of the register "Hardware config":

Register	Name	Description								
Rhwconfig	<i>Hardware configuration</i>	Set the default rotation direction of the motor encoder								
		<table border="1"><thead><tr><th>Bit</th><th>Stato</th><th>Description</th></tr></thead><tbody><tr><td rowspan="2">1</td><td>L</td><td>Standard rotation increments (CW)</td></tr><tr><td>H</td><td>Inverted rotation increments (CCW)</td></tr></tbody></table>	Bit	Stato	Description	1	L	Standard rotation increments (CW)	H	Inverted rotation increments (CCW)
		Bit	Stato	Description						
1	L	Standard rotation increments (CW)								
	H	Inverted rotation increments (CCW)								

FUNCTIONS ASSOCIATED WITH THE ROTARY SWITCHES

The rotary switches, placed in the front of the drive, are the only hardware setting devices.

Besides the definition of the communication address, some sequences are dedicated to some special functions which permit the interaction with the drive, also in absence of serial or fieldbus communication.

ADDRESSING

The main task of the rotary switches is to define the communication address. The configured address is common to all the communication protocols ((Modbus RTU, CANopen or Profibus).

By using the rotary switches, it is possible to select the addresses included in the range 1-89; for higher values, it is necessary to assign via software a value different from 0 to the address offset registers (Rseraddr, Rcanaddr and Rprofiaddr).

The value of the address offset registers is added to the value set with the rotary switches.

SPECIAL FUNCTIONS

Some combinations of the rotary switches are associated with special functions:

Rotary switch		Function	Description			
x10	x1					
0	0	<i>Default communication parameters</i>	If the drive is powered-on with this setting, it loads the following communication parameters:			
			Fieldbus	<i>Modbus RTU</i>	<i>CAN connected</i>	
			Address	125	125	125
			Baudrate	9600 bps	250 Kbps	Autobitrate
			Parity	Even	x	x
			Bit Nr.	8	x	x
			Stop bit	1	x	x
			Flux ctrl.	Nessuno	x	x
9	0	<i>Drive disable</i>	Abort the movement in progress and disable the drive			
9	1	<i>Drive Enable</i>	Enable the drive (only if the drive is configured correctly)			
9	2	<i>Stop User's program</i>	Stop the execution of the user program			
9	3	<i>Run User's program</i>	Run the execution of the user program			
9	4	<i>Reserved</i>	Reserved			
9	5	<i>Reserved</i>	Reserved			
9	6	<i>Reserved</i>	Reserved			
9	7	<i>Reserved</i>	Reserved			
9	8	<i>Reserved</i>	Reserved			

In order to activate the special functions (90, 91, 92, 93), proceed as follows: (all the operations must be performed with the drive powered-on)

1. Set the rotary switch of the units (x1) on the desired command;
2. Set the rotary switch of the tens (x10) on "9";

The execution of the command starts when the tens rotary switch is set.



CAUTION!!!

In case the tens rotary switch is already set on "9", select a different value and then repeat the previous procedure.

FIRMWARE UPDATE

FIRMWARE UPDATE

- Update StepControl to the latest version, by clicking on “Help” - “Check for updates” from the menu bar.

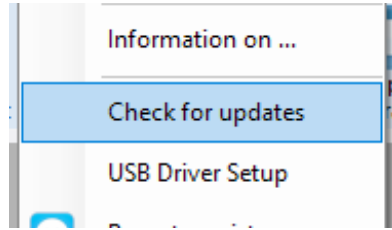

- Power the drive and connect the USB cable.
- Click on “Instruments->Drive firmware update” from the menu bar.

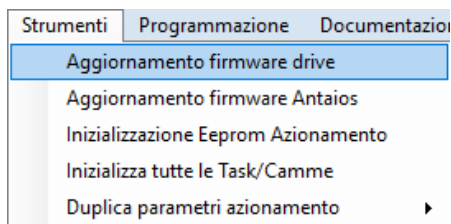

- Select the model of the drive.
- Select the “Serial port”.
- Load the firmware update file, by clicking on the button .
- Click on “Start Programming”.
- If the update has been completed correctly, the loading bar will stop and a dialog box with the message “Switch off the drive” will appear.
- Shut down and re-power the drive.

- Enable the communication by clicking on the icon  which will turn red.

- Disable the drive by clicking on the icon .

- Select the function “Instruments-> Drive Eprom initialize” to reset the data that may be remained into the drive.

- Now it is possible to upload a project into the drive.

- Disable the communication by clicking on the icon  which will turn green.

- Shut down and re-power the drive. The drive has been updated.

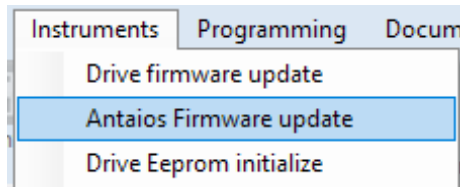

Only EtherCAT drives

- Power the drive and connect the USB cable.
- Click on “Instruments->Antaios firmware update” from the menu bar.

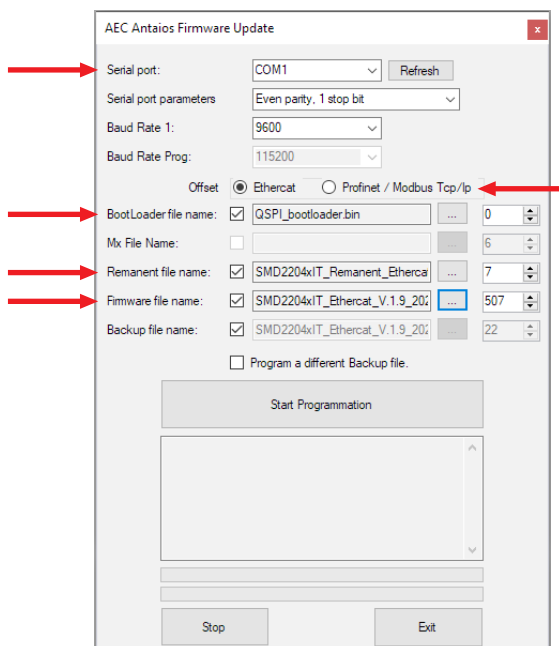

- The following dialog box will appear.



- Select the “Serial port”.
- Select the protocol.
- Load the “Bootloader” file from the update folder, by clicking on the button 
- Load the “Remanent” file from the update folder, by clicking on the button 
- Load the firmware update file from the update folder, by clicking on the button 
- Click on “Start Programming”.
- If the update has been completed correctly, the loading bar will stop and a dialog box with the message “Programming sequence completed” will appear.
- Shut down and re-power the drive. The drive has been updated.

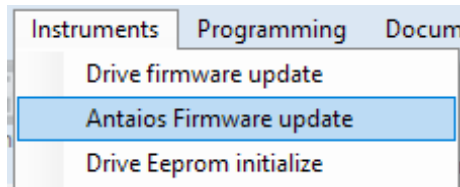

Only Modbus TCP/Profinet drives

- Power the drive and connect the USB cable.
- Click on “Instruments->Antaios firmware update” from the menu bar.

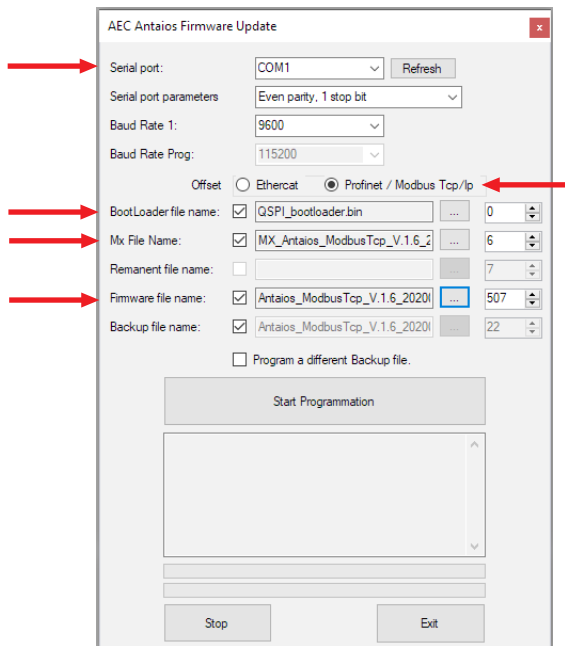

- The following dialog box will appear.



- Select the “Serial port”.
- Select the protocol.
- Load the “Bootloader” file from the update folder, by clicking on the button 
- Load the “Mx” file from the update folder, by clicking on the button 
- Load the firmware update file from the update folder, by clicking on the button 
- Click on “Start Programming”.
- If the update has been completed correctly, the loading bar will stop and a dialog box with the message “Programming sequence completed” will appear.
- Shut down and re-power the drive. The drive has been updated.

FOLLOWING CONTROL

GENERAL CHARACTERISTICS

The following control uses the feedback of an encoder connected to the motor, in order to verify real-time the correct movement and positioning of the motor itself.

The control constantly check the actual position and the encoder quota, in order to report a warning or an alarm in case the difference between the two quotas exceeds a configured threshold.

The following warning advise that the difference between the quotas exceeds the configured threshold and automatically resets in case the following error re-enters in the parameters set.

The following alarm, instead, in case the following error exceeds the threshold set, disables the drive and reports the fault state.

In this case it will be necessary to intervene and to reset the alarm to restore the system.



CAUTION!!!

The warning notice and the intervention of the following alarm can be masked by setting to 1 the bit 4 of the register *Rmaskwrn* (Warning smask) and *Rmaskalm* (Alarms mask).

The following error is automatically reset when the drive is disabled.

To deactivate the following control:

- Set to 0 the register *Rflwwrn* to disable the “Following warning” control
- Set to 0 the register *Rflwmax* to disable the “Following alarm” control

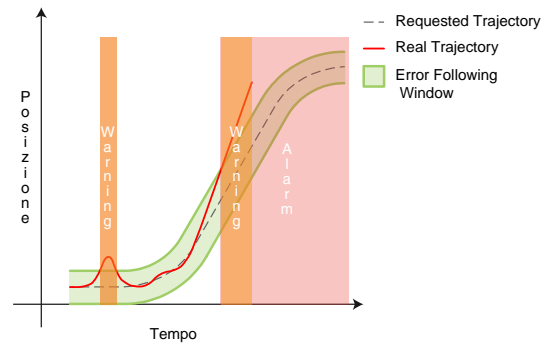
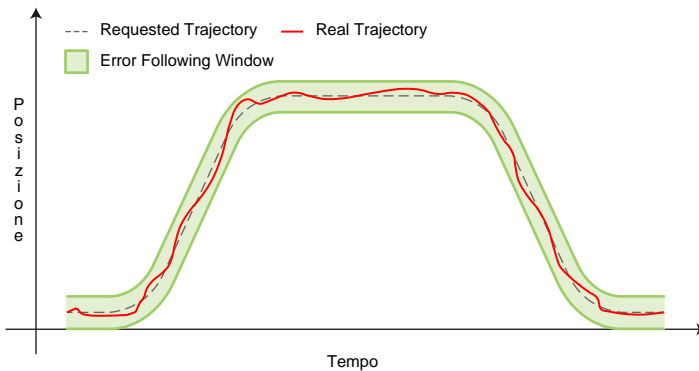

PARAMETERS

The Following control can be configured by setting the parameters below:

Register	Name	Description
<i>Rmotenc</i>	<i>Motor Encoder Pulse</i>	Set the number of pulses per revolution of the motor encoder
<i>Rflwmax</i>	<i>Maximum Following Error</i>	Define the intervention threshold of the following alarm in encoder pulses (set 0 to deactivate the control)
<i>Rflwwrn</i>	<i>Warning Following Error</i>	Define the intervention threshold of the following warning in encoder pulses (set 0 to deactivate the control)
<i>Rflwtim</i>	<i>Following Error Filter Time</i>	Set the filter time of the following error: the following alarm is signaled only if the following error exceeds the threshold set for a time equal or greater than the filter time. The following warning is signaled as soon as the following error exceeds the warning threshold without being filtered.
<i>Rmaskalm</i>	<i>Alarm Mask</i>	By setting to 1 the bit 4 the intervention of the following alarm is deactivated
<i>Rmaskwrn</i>	<i>Warning Mask</i>	By setting to 1 the bit 4 the intervention of the following warning is deactivated
<i>Rflwdisp</i>	<i>Actual Following Error Display</i>	Show the actual following error in encoder pulses
<i>Rflwmem</i>	<i>Max Absolute Following Error</i>	Store the maximum absolute following error occurred
<i>Rflwmemp</i>	<i>Max Positive Following Error</i>	Store the maximum positive following error occurred
<i>Rflwmemn</i>	<i>Max Negative Following Error</i>	Store the maximum negative following error occurred

POSITION CONTROL (SMART MODE AND SERVO MODE)

GENERAL CHARACTERISTICS

One of the main characteristics of the Smart and Servo modes is the impossibility for the motor to “lose steps”.

This doesn't mean that, applying a load greater than the maximum torque of the motor, the same will move, but that the drive is able to bring back the motor at the correct position soon as the conditions of the load permit it, modulating in the most efficient way the supplied current and the retrieval speed.

As already stated, since the movement of the motor (intended like parameters of current, accelerations and velocity) is controlled by the following error, it may occur cases in which, at the end of the requested movement, the device is not correctly positioned, but it is in delay of a certain number of encoder pulses.

In this case, the position control has the task to verify that the difference between the requested quota and the real quota doesn't exceed the value set in the positioning window, reporting the correct positioning or a position error.

The control function will report a position error also in case, with the motor in standstill, the load will take the motor out of position.

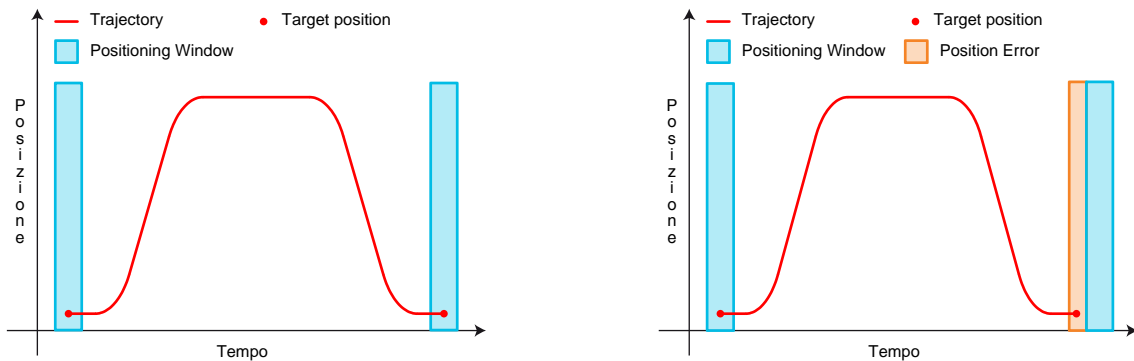

PARAMETERS

The position control can be configured by setting the parameters below:

Register	Name	Description
Rmotenc	<i>Motor Encoder Pulse</i>	Set the number of pulses per revolution of the motor encoder
Rflwmax	<i>Maximum Following Error</i>	Define the intervention threshold of the following alarm in encoder pulses (set 0 to deactivate the control)
Rflwwrn	<i>Warning Following Error</i>	Define the intervention threshold of the following warning in encoder pulses (set 0 to deactivate the control)
Rflwtim	<i>Following Error Filter Time</i>	Set the filter time of the following error: the following alarm is signaled only if the following error exceeds the threshold set for a time equal or greater than the filter time. The following warning is signaled as soon as the following error exceeds the warning threshold without being filtered.
Rmaskalm	<i>Alarm Mask</i>	By setting to 1 the bit 4 the intervention of the following alarm is deactivated
Rmaskwrn	<i>Warning Mask</i>	By setting to 1 the bit 4 the intervention of the following warning is deactivated
Rflwdisp	<i>Actual Following Error Display</i>	Show the actual following error in encoder pulses
Rflwmem	<i>Max Absolute Following Error</i>	Store the maximum absolute following error occurred
Rflwmemp	<i>Max Positive Following Error</i>	Store the maximum positive following error occurred
Rflwmemn	<i>Max Negative Following Error</i>	Store the maximum negative following error occurred

QUOTA REALIGNMENT

GENERAL CHARACTERISTICS

The VectorStep drives permit to realign the actual position and the encoder quotas “on the fly” at the occurrence of an event.

The realignment consists of setting some default values in the registers “actual position”, “motor encoder quota” and “external encoder quota”.

The triggering event can be the reading of an input managed in interrupt, a command sent via fieldbus, or sent by the internal program.

The realignment procedure starts when the register Rlineupcmd (Line-up command) is written: the command register (managed at bit) permits to define which quotas to align.

In case of realignment through input, the definition of the quotas to be aligned occurs by setting the register Rlineupdef (Line-up definition).

During the realignment, the interrupts of the drive are suspended in order to guarantee the maximum processing speed and the simultaneous process of all the quotas to be realigned.

At the end of the procedure, the command is reset by the drive



CAUTION!!!

It is inadvisable to use this function during deceleration ramps.

PARAMETERS

The realignment quota can be configured by setting the parameters below:

Registro	Nome	Description										
Rlineuppos	<i>Position line-up quota</i>	Set the realignment quota of the actual position. (At the activation of the realignment this value is copied in the position register)										
Rlineupmotenc	<i>Motor Encoder line-up quota</i>	Set the realignment quota of the motor encoder quota. (At the activation of the realignment this value is copied in the motor encoder quota).										
Rlineupextenc	<i>External Encoder line-up quota</i>	Set the realignment quota of the external encoder quota. (At the activation of the realignment this value is copied in the external encoder quota).										
Rlineupdef	<i>Line-up definition</i>	Define the quotas to be aligned at the activation of the quota alignment input: <table border="1" style="width: 100%; margin-top: 5px;"> <thead> <tr> <th>Bit</th> <th>Description</th> </tr> </thead> <tbody> <tr> <td>0</td> <td>Enable the actual position realignment</td> </tr> <tr> <td>1</td> <td>Enable the motor encoder quota realignment</td> </tr> <tr> <td>2</td> <td>Enable the external encoder quota realignment</td> </tr> <tr> <td>[3..15]</td> <td>Reserved</td> </tr> </tbody> </table> The alignment input is defined by associating the function “Align quota” with any of the drive inputs, from the “Inputs parameters” window.	Bit	Description	0	Enable the actual position realignment	1	Enable the motor encoder quota realignment	2	Enable the external encoder quota realignment	[3..15]	Reserved
Bit	Description											
0	Enable the actual position realignment											
1	Enable the motor encoder quota realignment											
2	Enable the external encoder quota realignment											
[3..15]	Reserved											
Rlineupcmd	<i>Line-up command</i>	Activate the procedure of alignment of the quotas set: <table border="1" style="width: 100%; margin-top: 5px;"> <thead> <tr> <th>Bit</th> <th>Description</th> </tr> </thead> <tbody> <tr> <td>0</td> <td>Align the actual position</td> </tr> <tr> <td>1</td> <td>Align the motor encoder quota</td> </tr> <tr> <td>2</td> <td>Align the external encoder quota</td> </tr> <tr> <td>[3..15]</td> <td>Reserved</td> </tr> </tbody> </table>	Bit	Description	0	Align the actual position	1	Align the motor encoder quota	2	Align the external encoder quota	[3..15]	Reserved
Bit	Description											
0	Align the actual position											
1	Align the motor encoder quota											
2	Align the external encoder quota											
[3..15]	Reserved											



CAUTION!!!

In case of realignment of more than one quotas (axis quota, motor encoder and/or external encoder) transfer the commands bit at the same moment in order to guarantee that the procedure is performed simultaneously.

MODULE QUOTA (ROLL-OVER)

GENERAL CHARACTERISTICS

The definition of a module quota permits the drive to work on a circular quota (cyclic), which results particularly useful in all “rotative” applications in which the drive cyclically perform the same run (rotary tables, conveyor belts etc.)

The working quota is “closed” in a loop between a minimum limit (fixed at 0) and a maximum limit (defined by the module quota).

Standard quota management (Signed32)

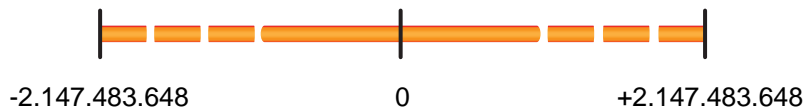

Module quota management

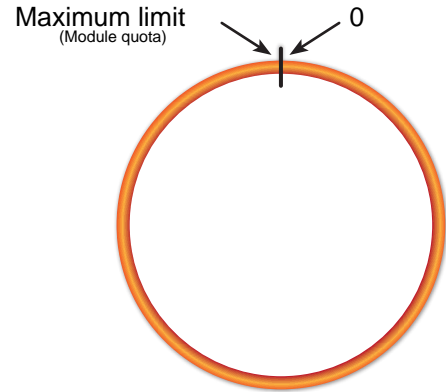

Moving the motor forward, at the exceeding of the upper limit, the quota returns to 0 and continues to increment. In the opposite case, with the motor moving backward, at the exceeding of the lower limit, the quota is imposed at the value of the module quota, continuing to decrement.

In addition to the module quota, it is possible to define if the requested quota must be reached by performing only forward or only backward movements, or by selecting the shortest path. In this way, it is possible to indicate the absolute quota inside the module range, and the quota is reached also if the drive must perform a “roll-over” of the quota (a passage through the zero or the maximum value).

Using the mode “Always forward direction”, in case it is requested a positioning at a quota lower than the actual one (eg. actual position = 500 and requested position = 400), the new position is reached by moving forward until the upper quota, returning to quota 0, and then moving forward until the requested quota is reached.

The same concept is valid for the “Always backward direction” mode, but reaching the requested quota by moving backward.

In “minimum distance” mode, the drive chooses the direction of movement, in order to cover the shortest distance..

Eg.:

	Only forward direction		Only backward direction		Minimum distance	
	Example A	Example B	Example A	Example B	Example A	Example B
Module quota	800	800	800	800	800	800
Actual quota	400	500	400	500	650	50
Requested quota	500	400	500	400	50	650
Rotation direction	Forward	Forward	Backward	Backward	Forward	Backward
Total travel	100	700	700	100	200	200

PARAMETERS

The module quota function can be configured by setting the parameters below:

Register	Name	Description														
Rmodulpos	<i>Position module quota</i>	Set the module quota for the actual position.														
Rmodulmotenc	<i>Motor Encoder module quota</i>	Set the module quota for the motor encoder.														
Rmodulextenc	<i>External Encoder module quota</i>	Set the module quota for the external encoder.														
Rmodulcmd	<i>Module command</i>	Enable and define the positioning mode in Module quota:														
		<table border="1"> <thead> <tr> <th>Bit</th> <th>Description</th> </tr> </thead> <tbody> <tr> <td>0</td> <td>Enable the position module in only forward direction</td> </tr> <tr> <td>1</td> <td>Enable the position module in only backward direction</td> </tr> <tr> <td>2</td> <td>Enable the position module in minimum distance</td> </tr> <tr> <td>3</td> <td>Enable the motor encoder module quota</td> </tr> <tr> <td>4</td> <td>Enable the motor encoder external quota</td> </tr> <tr> <td>[5..15]</td> <td>Reserved</td> </tr> </tbody> </table>	Bit	Description	0	Enable the position module in only forward direction	1	Enable the position module in only backward direction	2	Enable the position module in minimum distance	3	Enable the motor encoder module quota	4	Enable the motor encoder external quota	[5..15]	Reserved
		Bit	Description													
		0	Enable the position module in only forward direction													
		1	Enable the position module in only backward direction													
		2	Enable the position module in minimum distance													
		3	Enable the motor encoder module quota													
4	Enable the motor encoder external quota															
[5..15]	Reserved															

AUTOMATIC SAVE OF THE POSITION AT THE SHUT-DOWN

GENERAL CHARACTERISTICS

The SMD1204 is able to detect the voltage loss or a level of voltage lower than the minimum admitted value (23Vdc).

When this event occurs, the drive disables the output of current to the motor and saves actual position of the axis in the non-volatile memory, exploiting the residual charge of the power stage capacitors.

At the restart, the SMD1204 has the task to verify the quota saved in NVRAM and to report possible incongruencies.

In case the data is congruent, the saved value is copied in the register "Rposactsaved" and the flag of valid data is set; otherwise, both the saved quota register and the signalation flag will be equal to 0.



CAUTION!!!

In case of voltage loss with the motor in movement, the drive will save the quota reached at the moment of detection of the event. Even in case of congruent data, therefore, the saved quota can be considered valid only if the motor has not performed further movement caused by the load inertia or external actions (eg. operator intervention).



CAUTION!!!

In case the supply voltage has oscillations, the save of the quota is executed only at the first detection of voltage loss. The automatic save sequence is re-enabled at the restart of the drive.



CAUTION!!!

This function exploits the residual charge of the capacitors to perform all the necessary procedures for the writing of the data in the non volatile memory. In some cases, the available energy may not be sufficient to complete the procedure correctly..



CAUTION!!!

It is task of the operator to evaluate the the conditions, and possibly restore the actual quota by using the data saved at the shut-down..

PARAMETERS

Registro	Nome	Description							
Rposactsaved	Saved Position	Contain the axis quota saved at the last shut-down.							
Rposactsavedflag	Saved Position Flag	<table border="1"><thead><tr><th>Bit</th><th>Description</th></tr></thead><tbody><tr><td rowspan="2">0</td><td>H Valid saved data</td></tr><tr><td>L Invalid saved data</td></tr><tr><td>[1..15]</td><td>Reserved</td></tr></tbody></table>	Bit	Description	0	H Valid saved data	L Invalid saved data	[1..15]	Reserved
		Bit	Description						
		0	H Valid saved data						
L Invalid saved data									
[1..15]	Reserved								

LIMIT SWITCHES MANAGEMENT

HARDWARE LIMIT SWITCHES

The SMD1204 is able to manage independently the limit switch sensors, aborting possible movements in progress. The interruption of the movement occurs on the rising edge of the overtravel signal, by commanding a movement stop in emergency ramp (ABORT); any other movement, in the same direction of the interrupted one, is ignored, and only movements in the opposite direction are accepted..

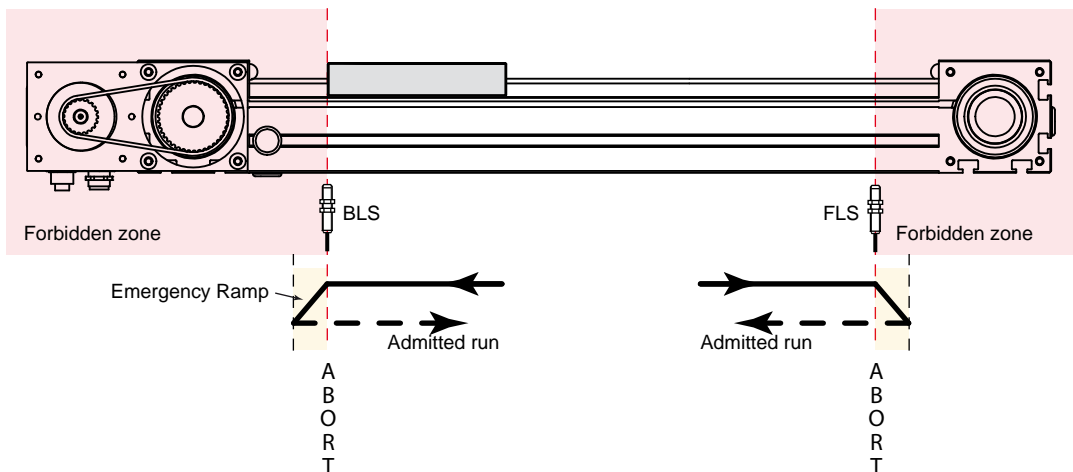

CAUTION!!!

After commanding a movement in opposite direction with respect to the forbidden one, the drive re-enables the possibility to move in both directions. Make sure that the motor has been brought inside the working zone (inside the two limit switches) before commanding further movements.

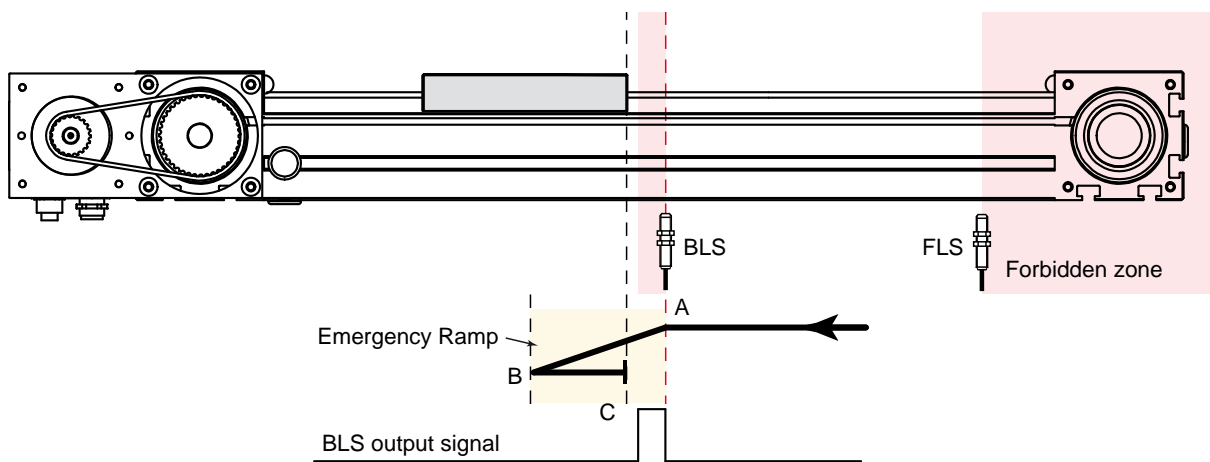

As shown in the illustration above, the drive blocks the movement after the intervention of the back limit switch (point A), braking the motor in emergency ramp until it stops in the point B.

In the point B, each movement command toward the the same direction of the interrupted movement will be aborted by the drive. If the motor is shifted to a point which is not inside the working area (eg. point C), the drive re-enables the possibility of movement in both directions, so from the poin C it will be possible to move the motor towards the point B.

Register	Name	Description													
Rflag	Flag Register	Enable the limit switches management													
		<table border="1"> <thead> <tr> <th>Bit</th> <th colspan="2">Description</th> </tr> </thead> <tbody> <tr> <td rowspan="2">4</td> <td>H</td> <td>Enable BLS limit switches management</td> </tr> <tr> <td>L</td> <td>Disable BLS limit switches management</td> </tr> <tr> <td rowspan="2">5</td> <td>H</td> <td>Enable FLS limit switches management</td> </tr> <tr> <td>L</td> <td>Disable FLS limit switches management</td> </tr> </tbody> </table>	Bit	Description		4	H	Enable BLS limit switches management	L	Disable BLS limit switches management	5	H	Enable FLS limit switches management	L	Disable FLS limit switches management
		Bit	Description												
		4	H	Enable BLS limit switches management											
L	Disable BLS limit switches management														
5	H	Enable FLS limit switches management													
	L	Disable FLS limit switches management													

SOFTWARE LIMITS

It is possible to let the drive manage software limit switches in order to limit the working stroke of a system: the upper limit quota defines the maximum value that the actual position of the axis can take, and the lower limit quota defines its minimum value.

Any movement command outside this quotas range is aborted or ignored by the drive, excepting homing commands.

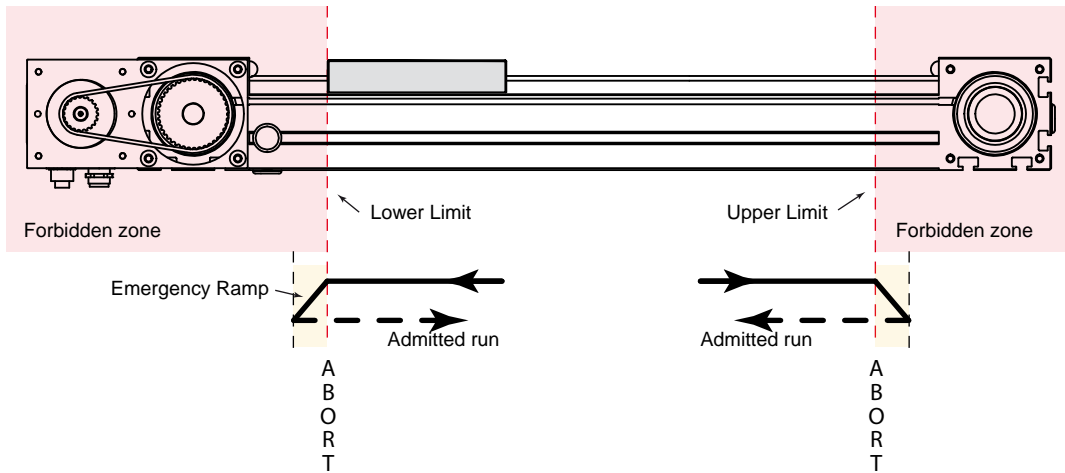

CAUTION!!!

If the actual position of the axis is outside the admitted zone at the moment of enabling of the software limits management, the drive will accept only movements toward the enabled direction (return movements from the forbidden zone)

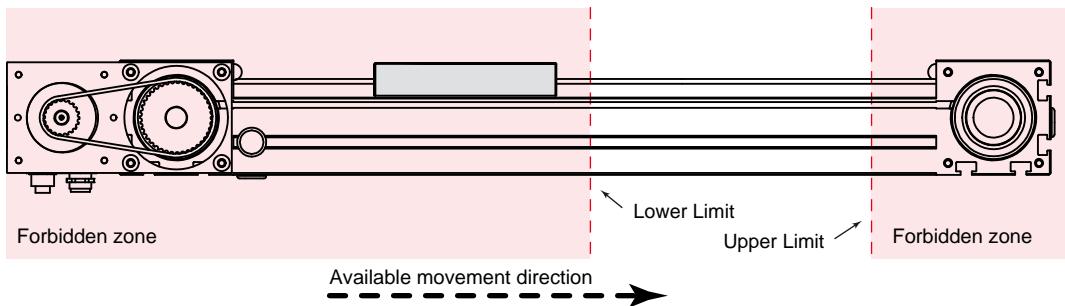

Per utilizzare la gestione delle quote limite è necessario, prima di abilitarne la gestione, definire il valore della quota limite inferiore e quello della quota limite superiore.

Registro	Nome	Description													
Rupplim	<i>Upper Limit</i>	Upper limit quota													
Rlowlimit	<i>Lower Limit</i>	Lower limit quota													
Rflag	<i>Flag Register</i>	Enable the limit quota management													
		<table border="1"> <thead> <tr> <th>Bit</th> <th colspan="2">Description</th> </tr> </thead> <tbody> <tr> <td rowspan="2">2</td> <td>H</td> <td>Enable lower limit quota management</td> </tr> <tr> <td>L</td> <td>Disable lower limit quota management</td> </tr> <tr> <td rowspan="2">3</td> <td>H</td> <td>Enable upper limit quota management</td> </tr> <tr> <td>L</td> <td>Disable upper limit quota management</td> </tr> </tbody> </table>	Bit	Description		2	H	Enable lower limit quota management	L	Disable lower limit quota management	3	H	Enable upper limit quota management	L	Disable upper limit quota management
		Bit	Description												
		2	H	Enable lower limit quota management											
L	Disable lower limit quota management														
3	H	Enable upper limit quota management													
	L	Disable upper limit quota management													

SIGNALATION LEDs

The SMD1204 drives are provided with 7 signalation leds:

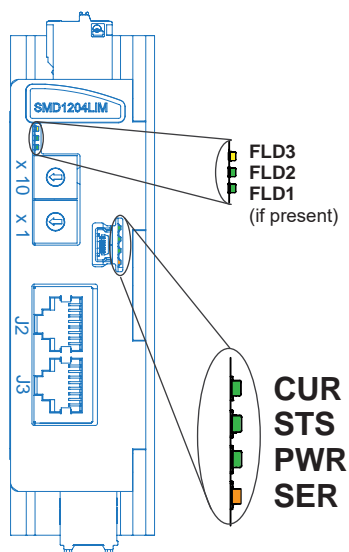

LED PWR

LED	Status	Description
PWR	●	Logic_Supply voltage lack
	●	Logic_Supply voltage present



LED CUR

LED	Status	Description
CUR	●	No current
	●	Reduced current
	●	Nominal current
	●	Boost current

LED STS

LED	Status	Description
STS	●	Drive is starting
	●	Drive OK
	●	Thermic protection is active
	●	Alarm is active or BOOT mode is active
	● ↔ ●	Power_Supply voltage lack

LED SER

LED	Status	Description
SER		USB communication is not active
		USB communication is active

LED FLD

For the FLD Led signlations, see the protocol manual.

DRIVE INFORMATION

GENERAL INFORMATION

By using StepControl©, it is possible to display the general information about the drive:

- Drive model
- Firmware version
- Hardware version
- Serial number
- Operation mode
- Status
- Operating temperature
- Working temperature
- User program status
- Antaios firmware version
- Antaios hardware version

Informazioni azionamento



Drive info

Tipo azionamento:	SMD22.04LIC
Versione Firmware:	05.25
Versione Hardware:	V 0.0
Numero di serie:	0
Modo di funzionamento:	Anello aperto posizione
Stato azionamento:	Abilitato:
Temperatura:	45 °C
Tensione:	60 Volt
Programma utente:	Programma non valido
Versione Firmware Antaios:	0,0
Versione Hardware Antaios:	0,0

Aggiorna

Esci

STATUS INFORMATION

They permit to know the actual status of the drive and they are helpful to look for the root causes of possible malfunctions:

- Hardware enable
- Software enable
- Current
- Forward limits
- Backward limits
- Software limits
- Home status
- Modbus status
- CAN status
- Profibus status
- Hardware alarm
- User program

● Abilitazione hardware	Potenza presente
● Abilitazione software	Abilitato
● Corrente	Riduzione automatica
● Finecorsa avanti	
● Finecorsa indietro	
● Limiti software	
● Home	Azzerato
● Modbus status	On Line
● CAN status	Disabilitato
● Profibus status	Disabilitato
● Allarme hardware	
● Programma utente	Programma OK

ALARMS

The drive is able to notify hardware and software alarms that occurred, in order to give useful information for the acknowledgment and the resolution of possible anomalies.

The possible alarms are

- HW overcurrent
- SW overcurrent
- I²T intervention
- Position
- Following
- Temperature
- Digital outputs overload
- Over voltage
- Under voltage

In the Status window, the alarms are notified with a red LED and the relative red icon.



WARNINGS

In addition to the alarms, the drive is able to notify warnings that occurred, in order to acknowledge possible abnormal conditions in advance.

The possible warnings are

- HW overcurrent
- SW overcurrent
- I²T intervention
- Position
- Following
- Temperature
- Digital outputs overload
- Over voltage
- Under voltage
- Limited output current from V_{bus}
- Saturated PI regulator
- Current limit is active

In the Status window, the warnings are notified with an orange LED and the relative orange icon.



DIAGNOSIS AND REMOVAL OF ANOMALIES

The drive is able to manage several protection functions.

When an alarm is generated, the motor is immediately stopped and the anomaly is simultaneously notified through the STS LED, the fieldbus and the alarm output (if configured).

The drive is also able to provide prior indications about functioning anomalies or warnings.

The occurrence of a warning does not intervene on the functioning of the motor, but it permits to notify through the Status registers abnormal conditions that might lead to an alarm intervention.

To restore a drive in fault state, it is necessary to reset the active alarms, or to disable and re-enable the drive: this operation can be executed through I/O, user program or fieldbus.

ALARMS DETAILS

Type of alarm	Cause	Actions
HW Overcurrent	<p>The current supplied by the the drive exceeds the maximum admitted current.</p> <ol style="list-style-type: none"> 1. Fault of the drive (defective device, MOSFET failure, ecc) 2. Shortcircuit between phases (A, A-, B, B-) 3. Shortcircuit towards the earth 4. Motor burned 5. Shortcircuited or damaged cables 	<ol style="list-style-type: none"> 1. Disconnect the motor cable and enable the drive. If the alarm persists, replace the drive. 2. Check that the motor phases are not shortcircuited, that the cables are intact and properly connected. 3. Measure the insulation resistance between the motor phases and the earth; in case of bad insulation, replace the motor. 4. Measure the windings resistances of the motor; in case they are not balanced, replace the motor. 5. Check the integrity of cables and connectors.
SW Overcurrent	<p>The current requested by the positioner exceeds the maximum configured threshold.</p> <ol style="list-style-type: none"> 1. Dynamic is too high 2. Phase Advance is too high 	<ol style="list-style-type: none"> 1. Reduce the acceleration/deceleration ramps and the maximum speed. 2. The inertia of the load doesn't permit too high Phase Advance values.
Over Voltage	<p>The supply voltage exceeds the maximum allowed limit.</p> <ol style="list-style-type: none"> 1. Voltage peak 2. The regenerated energy cannot be absorbed 	<p>Measure the supply voltage on the connector M1 and make sure that it is included within the permissible ranges.</p> <ol style="list-style-type: none"> 1. Make sure that possible fluctuations or voltage peaks don't generate a voltage outside the permitted range. 2. Increase the capacity of the supply stage.
Under Voltage	<p>The supply voltage is lower than the minimum allowed limit.</p> <ol style="list-style-type: none"> 1. Voltage is too low 2. The output capacity of the power supply stage is not sufficient 	<p>Measure the supply voltage on the connector M1.</p> <ol style="list-style-type: none"> 1. Increase the supply voltage 2. Increase the capacity of the supply stage.
Temperature	<p>The temperature of the drive exceeds the maximum configured threshold.</p> <ol style="list-style-type: none"> 1. Lacking or insufficient ventilation 2. Insufficient distance between the units 3. Heat sources proximity 	<ol style="list-style-type: none"> 1. Increase the ventilation to improve the exceeding heat dissipation. 2. Increase the distance between the units to improve the air flow. 3. Move the unit away from heat sources.

Type of alarm	Cause	Actions
I²T	The working dynamics or the system calibration generate a too high thermal image of the motor.	Check that the motor is properly sized for the application and that the calibration of the parameters of the control loops is correct.
Output overload	The current supplied by the digital outputs is too high. 1. Shortcircuit 2. The load absorbing is too high	 1. Remove the shortcircuit on the load. 2. Check that the requested current by the load is compliant with the characteristics of the digital output.
Following	The following error exceeds the configured threshold. 1. The motor doesn't respond to the commands 2. The error threshold is too low	 1. Check that the motor correctly follows the requested target. Make sure that the requested torque does not exceed the motor torque; optimize the parameters of the control PID; reduce accelerations and decelerations. 2. Set an higher error threshold.
Position	The position error exceeds the configured threshold. 1. The motor doesn't respond to the commands 2. The error threshold is too low	 1. Check that the motor torque is sufficient to keep the position; check the calibration of the position PID 2. Set an higher error threshold.
Encoder phase	The drive doesn't recognize any valid encoder. 1. Wrong encoder connection 2. Encoder phase is interrupted 3. Load blocked during phasing	Check the correct power supply of the encoder; in case of long cables, pay particular attention to the wiring layout. Use shielded cables and keep the power cables separated from the signal cables. 1. Check the connection of the phases 2. Check the encoder cable 3. Remove the cause of the load blocking
Phase A error	The drive doesn't recognize the phase A of the motor. 1. Interrupted cable 2. Damaged connector	 1. Check the integrity of the cable 2. Check the integrity of the connector pins and that the connector is well fixed.
Phase B error	The drive doesn't recognize the phase B of the motor. 1. Interrupted cable 2. Damaged connector	 1. Check the integrity of the cable 2. Check the integrity of the connector pins and that the connector is well fixed.

WARNINGS DETAILS

Type of warning	Cause	Actions
HW Overcurrent	<p>The current supplied by the the drive is close to the maximum admitted current.</p> <ol style="list-style-type: none"> 1. Fault of the drive (defective device, MOSFET failure, ecc) 2. Dispersion between phases (A, A-, B, B-) 3. Dispersion towards the earth 4. Motor burned 5. Shortcircuited or damaged cables 	<ol style="list-style-type: none"> 1. Disconnect the motor cable. If the notification persists, replace the drive. 2. Check that the integrity of the insulation between the phases. 3. Measure the insulation resistance between the motor phases and the earth; in case of bad insulation, replace the motor. 4. Measure the windings resistances of the motor; in case they are not balanced, replace the motor. 5. Check the integrity of cables and connectors.
SW Overcurrent	<p>The current requested by the positioner is close to the maximum configured threshold.</p> <ol style="list-style-type: none"> 1. Dynamic is too high 2. Phase Advance is too high 	<ol style="list-style-type: none"> 1. Reduce the acceleration/deceleration ramps and the maximum speed. 2. The inertia of the load doesn't permit too high Phase Advance values.
Over Voltage	<p>The supply voltage is close to the maximum allowed limit.</p> <ol style="list-style-type: none"> 1. Voltage peak 2. The regenerated energy cannot be absorbed 	<p>Measure the supply voltage on the connector M1 and make sure that it is included within the permissible ranges.</p> <ol style="list-style-type: none"> 1. Make sure that possible fluctuations or voltage peaks don't generate a voltage outside the permitted range. 2. Increase the capacity of the supply stage.
Under Voltage	<p>The supply voltage is close to the minimum allowed limit.</p> <ol style="list-style-type: none"> 1. Voltage is too low 2. The output capacity of the power supply stage is not sufficient 	<p>Measure the supply voltage on the connector M1.</p> <ol style="list-style-type: none"> 1. Increase the supply voltage 2. Increase the capacity of the supply stage.
Temperature	<p>The temperature of the drive is close to the maximum configured threshold.</p> <ol style="list-style-type: none"> 1. Lacking or insufficient ventilation 2. Insufficient distance between the units 3. Heat sources proximity 	<ol style="list-style-type: none"> 1. Increase the ventilation to improve the exceeding heat dissipation. 2. Increase the distance between the units to improve the air flow. 3. Move the unit away from heat sources.
I²T	<p>The working dynamics or the system calibration generate a too high thermal image of the motor.</p>	<p>Check that the motor is properly sized for the application and that the calibration of the parameters of the control loops is correct.</p>
Output overload	<p>The current supplied by the digital outputs is too high.</p> <ol style="list-style-type: none"> 1. Shortcircuit 2. The load absorbing is too high 	<ol style="list-style-type: none"> 1. Remove the shortcircuit on the load. 2. Check that the requested current by the load is compliant with the characteristics of the digital output.

Type of warning	Cause	Actions
Following	<p>The following error is close to the configured threshold.</p> <ol style="list-style-type: none"> 1. The motor doesn't respond to the commands 2. The error threshold is too low 	<ol style="list-style-type: none"> 1. Check that the motor correctly follows the requested target. Make sure that the requested torque does not exceed the motor torque; optimize the parameters of the control PID; reduce accelerations and decelerations. 2. Set an higher error threshold.
Position	<p>The position error is close to the configured threshold.</p> <ol style="list-style-type: none"> 1. The motor doesn't respond to the commands 2. The error threshold is too low 	<ol style="list-style-type: none"> 1. Check that the motor torque is sufficient to keep the position; check the calibration of the position PID 2. Set an higher error threshold.
Limited current from V_{BUS}	<p>The bus voltage does not permit to supply the requested current at the actual working speed. It indicates that in the current condition the motor is not able to supply the nominal torque.</p> <ol style="list-style-type: none"> 1. Supply voltage is too low 2. Working speed is too high 3. Wrong motor parameterization 	<p>Increase the supply voltage, reduce the working speed, check the motor parameterization..</p> <ol style="list-style-type: none"> 1. Increase the supply voltage 2. Reduce the working speed 3. Check the motor parameters
Saturated regulator	<p>The drive is not able to meet the current requested at the actual working conditions (voltage and speed).</p> <ol style="list-style-type: none"> 1. The requested current/torque/speed are not compatible with the system characteristics 	<p>The drive is supplying the whole available power, but it isn't able to meet the current/torque/speed request.</p> <ol style="list-style-type: none"> 1. Increase the supply voltage (if possible), reduce the current/torque/speed request, modify the defluxing parameters. <p> The motor defluxing reduces the torque for the benefit of the speed. Modify these settings only if strictly necessary and in any case with knowledge of the facts..</p>
Limitazione di corrente attiva	<p>The drive is limiting the current supplied to the motor.</p> <ol style="list-style-type: none"> 1. The register Rcurtorque has a value not equal to 0 and lower than the nominal current. 	<p>In case a current limitation is not required, set the parameter Rcurtorque to 0, or to a value higher than the nominal current.</p>

PRELIMINARY CHECKS

Make sure that the STS LED doesn't become red or orange. In case the LED blinks red/green check the supply voltage.

Check that the connectors are properly inserted and that all the connections are correct and intact. Make sure that the supply voltage is, in all cases (line fluctuations or energy recovery), a DC voltage within the admitted range.

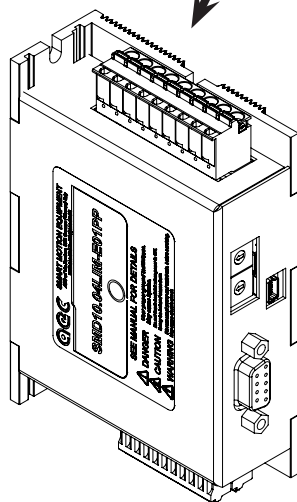

Check that the connectors and the possible terminations are correctly inserted. Make sure that all the wiring rules have been respected.

Check that the connectors are properly inserted and that all the connections are correct and intact.

Preliminary checks on the mechanics:

- Check that the motor is free to rotate and that there aren't mechanical impediments
- Make sure that during the movement no electromagnetic holding brakes intervene
- Make sure that the mechanical coupling is correct, not loose, and that there are no torque peaks.
- Make sure that the requested dynamics are compatible with the characteristics of the servo-drive
- Check that the motor doesn't generate anomalous noises.

THE MOTOR DOESN'T ROTATE

Category	Cause	Corrective action
Parameters	Wrong control mode	Check the selected control mode: Open loop (sensorless) Closed loop (encoder is required)
	Wrong function mode	Check the configured function mode: Current Velocity Position Step/Direction
	SW enabling	Check that the device enables the current output.
	Current limitation	Make sure that the parameter Rcurtorque is not set at a too low value that does not permit to overcome the breakaway friction of the system.
	Maximum speed	Check that the parameter Rvelmax is not equal to 0.
	Target absent	Make sure that the drive receives a target compatible with the selected function mode.
	Software limits	Make sure that the requested quota is within the range defined by software limits.

Category	Cause	Corrective action
Connections	HW enabling	Check that the power stage is properly supplied (HV_Power). In case an enabling input is configured, check the presence of a valid logic state at the input.
	Overtravel	In case the automatic management of the limit switches is enabled, make sure that the BLS (Backward Limit Switch) and the FLS (Forward Limit Switch) inputs are not active.
	Step and DIR signal absence	In case of Step and direction function mode, check the connection of the signals Step IN and DIR
Installation	The shaft of the motor is blocked	Disable the drive and disconnect the motor from the mechanical part. Try to rotate the shaft with an hand; in case it is blocked, contact the seller. In case of electromagnetic brake, open the brake before making this test.

THE ROTATION IS NOT SMOOTH

Category	Cause	Corrective action
Calibration	The gains of the position loop are too low	Increase the proportional gain Kp of the velocity loop
	Unstable speed reference	In case of reference from analog, check that the signal is stable and not disturbed (show Rvel through the oscilloscope). In case of step and direction mode, check that the signal in frequency is stable and not disturbed.
Connections	Disturbances on the reference signal	Check the connection and the shielding. Move away the signal cables from the power cables. Provide the proper filters on the power cables.

LOW POSITIONING ACCURACY

Category	Cause	Corrective action
System	Position command error	Make sure that the target quota sent to the drive is correct; in case of step and dir mode, check that the number of pulses generated by the controller is correct: repeat the test several times and check that the number of pulses is always the same. In case the number of pulses varies, check the correct functioning of the controller.
	The characteristics of the command does not meet the requested requirements	Make sure that the target quota and the movement parameters have the same measuring unit. In step and direction mode, make sure that the Step IN signal is not deformed or too short.
Calibration	The gains of the position loop are too low	In closed loop mode, check the calibration of the position loop.
Parameters	Positioning window is too wide	Reduce the value of the positioning window (Rdeadpos)
	The frequency of the Step signal exceeds 1 MHz.	Reduce the driving frequency; modify the resolution of the motor.
	Wrong motor resolution	Check the setting of the motor resolution.
	Velocity loop Kp is too high	Reduce the velocity Kp in order to per stabilize the behavior of the motor when it's stopped.

Category	Cause	Corrective action
Connection	The following signals are not stable: <ul style="list-style-type: none"> • Drive enable (if configured) • Current reduction (if configured) • Step IN (Step and direction mode) 	Check the connection and shielding of the signals. Separate the signal conductions from the power conductors. Check the functioning of the controller (HOST)
Installation	The inertia of the load is high	In case of load oscillations also after the best calibration of the control loops, increase the torque deliverable by the system (motor and drive)

LOW ACCURACY OF ZERO POSITION

Category	Cause	Corrective action
System	The zero signal is not recognized	Make sure that the homing input is activated.
	Homing speed is too high	Reduce the zero point search speed.
Connection	Unstable zero signal	By using an oscilloscope, make sure that there are no bounces of the zero signal. Check the wiring and take the proper actions in order to reduce possible disturbances.
	Zero signal absence	Make sure that the signal is properly connected and the cable is intact.

ANOMALOUS NOISE

Category	Cause	Corrective action
Parameters	The gains of the control loop are too high	Reduce the proportional gains of the control loop.
Connessione	Mechanical resonances	Check the parameterization of the system and the mechanical installation of the device.
	Motor bearings	Disconnect the motor from the load and check if the noise is referable to the motor bearing.
	Electromagnetic noise, mechanical noise of the gears...	Disconnect the motor from the load and check if the noise is still present.

THE USER PROGRAM DOESN'T START AT THE POWER-ON

Category	Cause	Corrective action
Parameters	Wrong start-up parameters	In the startup parameters of the drive, define the function "Autorun"
	Invalid program	Make sure that a valid program is present

THE PARAMETERS DON'T KEEP THE NEW VALUE

Category	Cause	Corrective action
Parameters	Parameter is not saved	All the modifications are transferred in the drive RAM. To make them definitive, send the save in NVRAM command.