

UNIMOTION

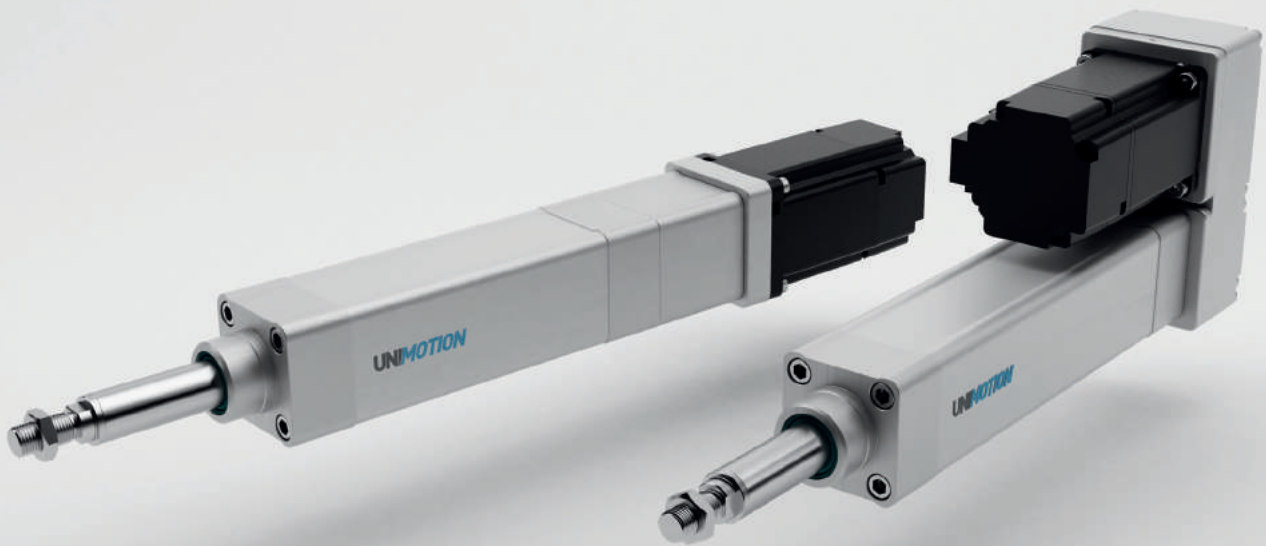



MAINTENANCE- AND ASSEMBLY

INSTRUCTIONS PNCE
ELECTRIC CYLINDER

INDEX

General information	1
Symbols used	1
Recommended tightening torques for screws	1
General safety instructions	1
Safe operation	1
Modification of the electric cylinder	2
Labels and notices	2
Warranty	2
Operating conditions	2
Product description	3
Standard version	3
IP65 protection class (IP65)	3
IP65 protection class with high corrosion resistance (IP65CR)	3
For applications in the food industry (FI)	3
Identification label and additional or replacement parts of the electric cylinder	4
Handling the electric cylinder	5
Storing the electric cylinder	6
Mounting	6
Accessories - overview	7
Permissible loads	8
Magnetic field sensor - reed switch	10
Motor adapter with coupling	12
Motor side drive with timing belt	15
Maintenance	19
Lubrication of the ball screw drive	19
Lubricant	19
Lubricant quantities and intervals	19
Lubrication position	19
Normal operating conditions	19
Cleaning of the electric cylinder	20
Start-up	20
Assembly of the PNCE - overview	20
Replacement of the assemblies	21
Replacing the front cap assembly	21
Replacing the PNCE main assembly	21







GENERAL INFORMATION

-  It is important to read this instruction manual before handling the product. Otherwise the electric cylinder might get damaged.
-  Some detailed information, which is not presented in this document, can be found in our catalogue UNIMOTION Electric cylinder PNCE.



Link to the catalogue Unimotion
Electric cylinder PNCE

Used symbols

-  Remark, note
-  Warning!
-  Danger!
Risk of coming into contact with power conducting parts! Cut off the power supply!
-  Tightening torque
-  For more information see the catalogue
-  Use different tightening torques as are presented in Table 1 (page 1)
-  In this Instruction manual, **PNCE** represents abbreviation for the electric cylinder with a precision ball screw drive.

Recommended tightening torques for screws

8.8	M2	M2,5	M3	M4	M5	M6	M8	M10	M12
$M_{A,max}$ [Nm]	0,4	0,7	1,3	2,8	5,6	9,6	23	45	74

Table 1: Recommended tightening torques for screws of strength class 8.8.

GENERAL SAFETY INSTRUCTIONS



To ensure the right functionality of the electric cylinder - PNCE, it must be handled with care. It is not allowed to put any tools or any other items which can cause damage to the electric cylinder on the electric cylinder.
The electric cylinder must be protected against any liquid that can cause damage to it.
The electric cylinder - PNCE with IP65 protection class fulfils the specifications to IEC 60 529.
For information on the conditions in which the electric cylinder can operate please see section **Operating conditions** or contact us. If the electric cylinder isn't in use, place it in a dry, clean environment and cover it to prevent any damage.

Safe operation

The electric cylinder must not be put into service until the final machinery into which it is installed has been declared in conformity with the provisions of the Machinery Directive, where appropriate.
Each operation of the electric cylinder that is not in compliance with its intended use can lead to the product being damaged, or can cause accidents and at the same time stoppages in production. To ensure a safe operation please refer to this Instruction Manual and the operating manual of other machinery where the electric cylinder is to be incorporated.

The electric cylinder satisfies the requirements of the EC Machinery Directive 2006/42/EC according to the European or national standards of Safety of machinery:

EN ISO12100-1
EN ISO 12100-2

-  **Checking the electric cylinder**
In accordance with the EU Health and Safety Directive 89/655/EEC Article 4a, the operating company must subject the unit (cylinder) to thorough checking prior to putting it into operation; after carrying out repairs, and after malfunctions have occurred.
-  **Requirements for personnel**
The electric cylinder may only be installed, operated, maintained, repaired or dismantled by appropriately qualified personnel in accordance with the specification User manual. All qualified personnel must have read and understood this Instruction manual.

Modification of the electric cylinder

The electric cylinder must not be modified without our written consent. Any such unauthorized modification will make void our liability in respect of the unit (cylinder). The operating company may only carry out the maintenance and repair work detailed in this Instruction manual.

Labels and notices

All notices and labels attached to the electric cylinder must be fully visible and must not be removed. They must ensure compliance with all the instructions contained on them. Damaged or illegible notices and labels must be replaced.

Warranty



The warranty conditions are laid down in the terms and conditions of delivery and payment issued at the time of order. Warranty cover will be annulled if:

- the electric cylinder is not operated in accordance with the stipulated regulation use;
- the instructions set out in this operating manual are not followed;
- the electric cylinder is modified without the consent of the manufacturers;
- the screws sealed by locking varnish are unlocked.

The manufacturer's warranty in respect of maintenance and repair work applies only if original replacement parts are used.

OPERATING CONDITIONS

Operating temperature	0°C ~ +60°C
Protection class	IP40, IP65
Duty cycle	100 %

-  In case of special operating conditions, please contact us.
-  For the values of the maximum permissible axial load, lateral load, drive torque, travel and rotational speed and acceleration please see our catalogue UNIMOTION Electric cylinder PNCE.
-  Overloading the electric cylinder can lead to the product being damaged.

PRODUCT DESCRIPTION

• Standard version (S)*

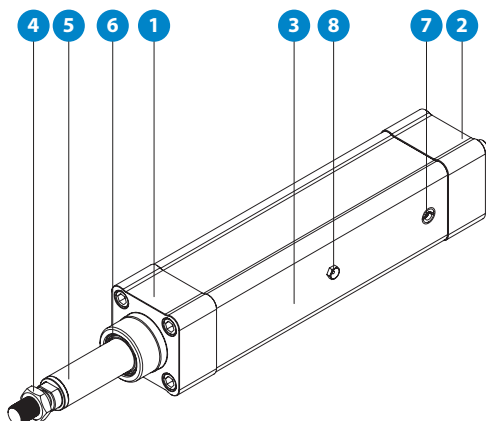

- 1 – Front cap
- 2 – Drive cap
- 3 – Smooth cylinder profile
- 4 – Hex nut
- 5 – Piston rod (stainless steel) with an anti-rotation device
- 6 – Piston rod seal
- 7 – Pressure compensation
- 8 – Lubrication nipple

* IP40 protection class

Figure 1: Structural design of the standard version of the PNCE.

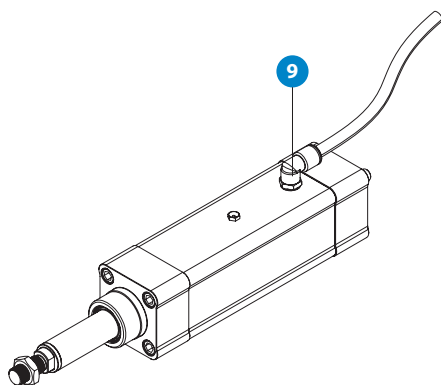

- 9 – Connection for pressure compensation

Figure 2: Structural design of the IP65 version of the PNCE.

• IP65 protection class (IP65)



The appropriate sealing of the external parts ensures the electric cylinder the IP65 protection class. The IP65 protection class of the electric cylinder fulfils the specifications to IEC 60 529. The connection for pressure compensation in the cylinder profile ensures the exchange of air between the interior of the cylinder and the environment. This prevents the occurrence of excess pressure or negative pressure inside the electric cylinder. It also protects the interior of the cylinder from the external media like dust and water.

• IP65 protection class with high corrosion resistance (IP65CR)



It offers high corrosion resistance in harsh environments. The version IP65CR includes all the features of the electric cylinder version IP65. In addition to ensuring high corrosion resistance all the external parts are corrosion resistant (e.g. the connection for pressure compensation, lubrication nipple, and the connection elements are made of stainless steel). More information about materials is available upon request in the extended material information list.

• For applications in the food industry (FI)



The version FI includes all the features of the electric cylinder version IP65CR. It is upgraded by materials suitable for some applications in the food industry. The cylinder is greased with a lubricant class NSF H1. The design with the smooth surfaces of the aluminium profile enables its quick and effective cleaning. During the cleaning the sealing air can be applied to the connection for pressure compensation. The use for the food & beverage industry is limited by the materials of the electric cylinder. More information about materials is available upon request in the extended material information list.

Identification label and additional or replacement parts of the electric cylinder

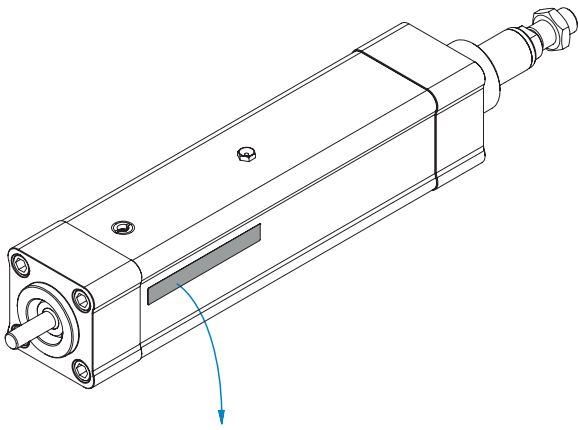

- 1 - ID number
- 2 - Serial number
- 3 - No load torque [Nm]
- 4 - Axial backlash [mm]
- 5 - Type of electric cylinder (ordering code)



In case of ordering additional or replacement parts for the electric cylinder all data must be given from the identification label.



The label must be fully visible and must ensure compliance with all the instructions it contains. Damaged or illegible labels must be replaced.

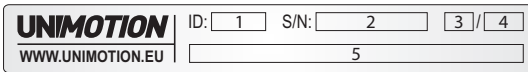

Figure 3: Identification label of the electric cylinder.

HANDLING THE ELECTRIC CYLINDER

The electric cylinder is carefully packed for its safe transportation.

To correctly carry of the electric cylinder, please take into consideration the following handling instructions:

- during carrying, the piston rod must be retracted, see Figure 4 - 1,
- the electric cylinder must only be lifted by the cylinder profile or by the front cap (using the eye bolts), see Figure 4 - 1 → 6,
- during carrying, the electric cylinder must be prevented from swinging, see Figure 4 - 4,
- the electric cylinder must never be lifted by the piston rod or by the drive cap only (since the ball screw drive is not self-locking), see Figure 4 - 6 and 7.

A suitable lifting tool for transporting of the electric cylinder is needed. Always lift and carry the electric cylinder by the cylinder profile or by the front cap. Prevent the electrical cylinder from dropping.

 Never stand under the loads being carried.

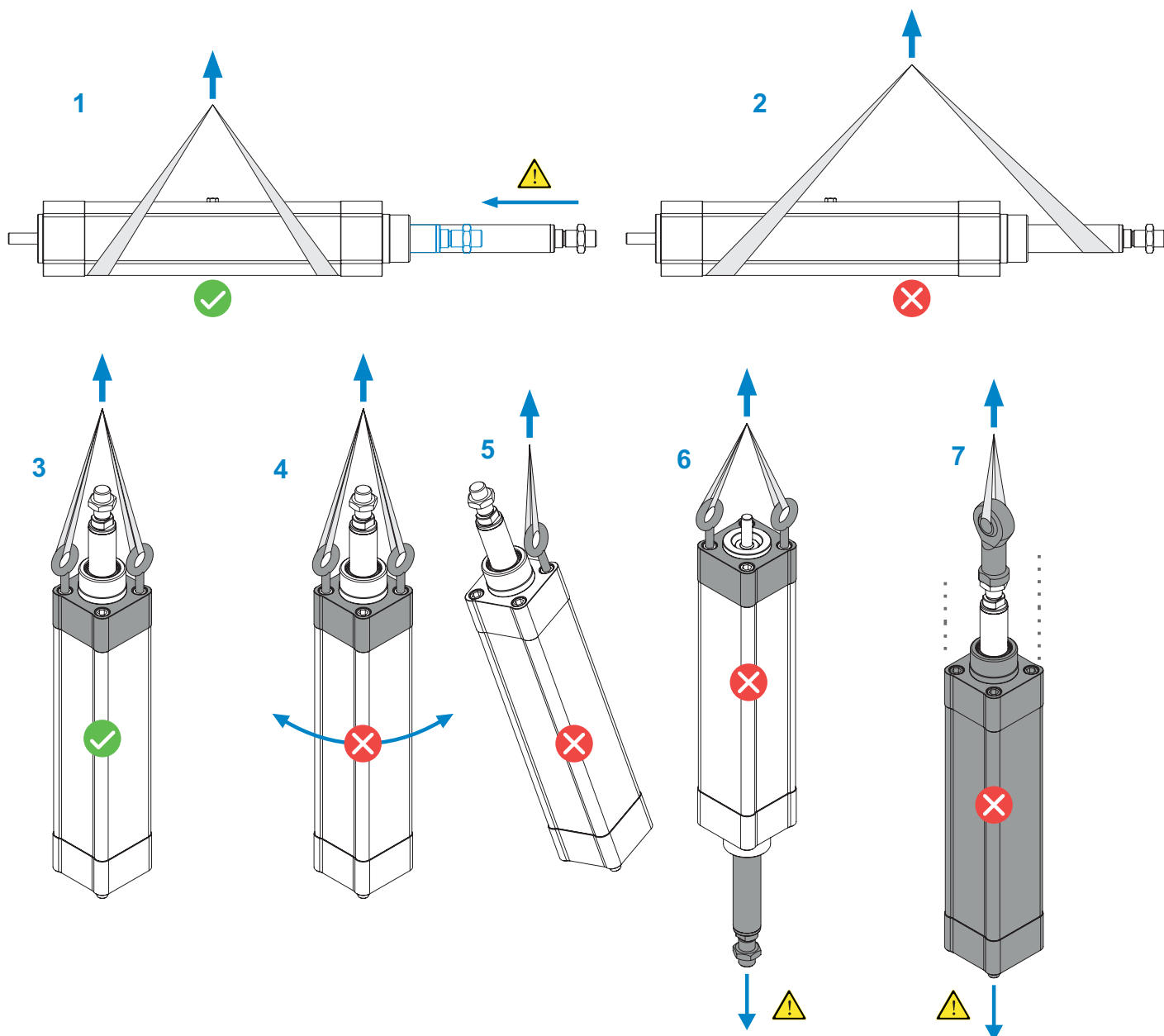



Figure 4: Carrying the electric cylinder.

-  The weight of the electric cylinder should be calculated in order to choose the suitable lifting tool for transporting the electric cylinder.
-  For the weight calculations, please refer to the catalogue UNIMOTION Electric cylinder PNCE.

Storing the electric cylinder

The electric cylinder needs to be stored in a dry place and protected against corrosion. Make sure that there is no danger of the electric cylinder getting damaged.

MOUNTING

The electric cylinder can be mounted as follows (see figure 5):

- 1 - by the front cap
- 2 - by the piston rod
- 3 - by the drive cap and motor adapter - VK
- 4 - by the motor side drive - MSD
- 5 - by the cylinder profile

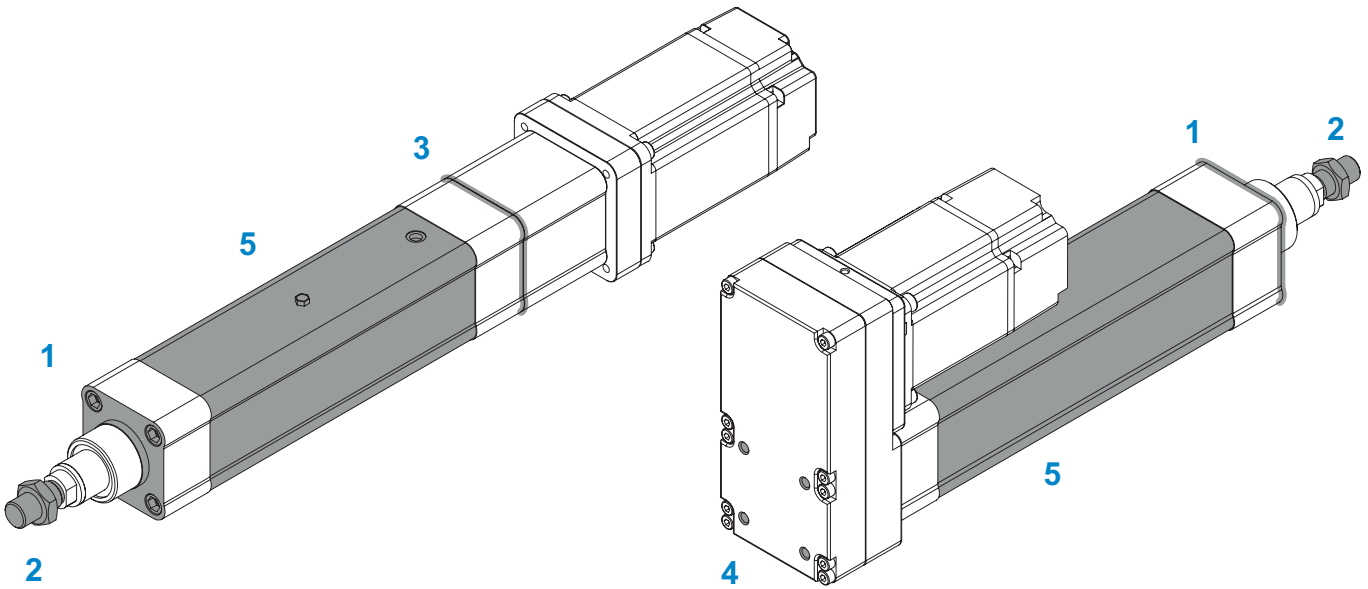

Figure 5: Mounting options.

i The electric cylinder can be installed in any orientation using a suitable combination of mounting attachments.

! When the electrical cylinder is installed vertically or in an inclined position, prevent the piston rod from dropping due to the no self-locking effect of the ball screw drive, Figure 6. To avoid dropping the piston rod it is advisable to install a suitable motor with a holding brake.

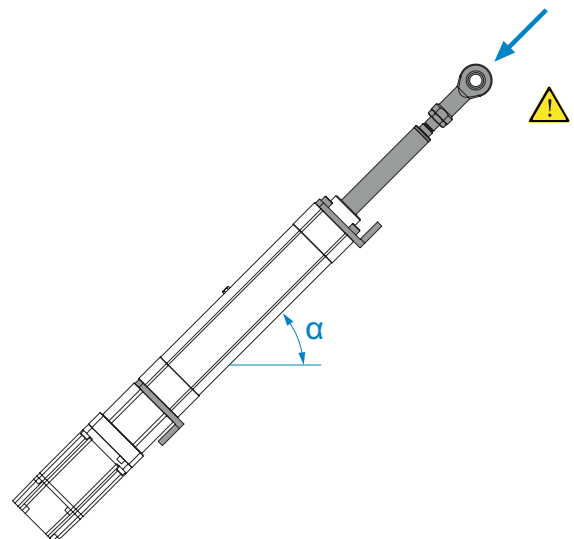

Figure 6: Dropping of the piston rod.

Accessories - overview

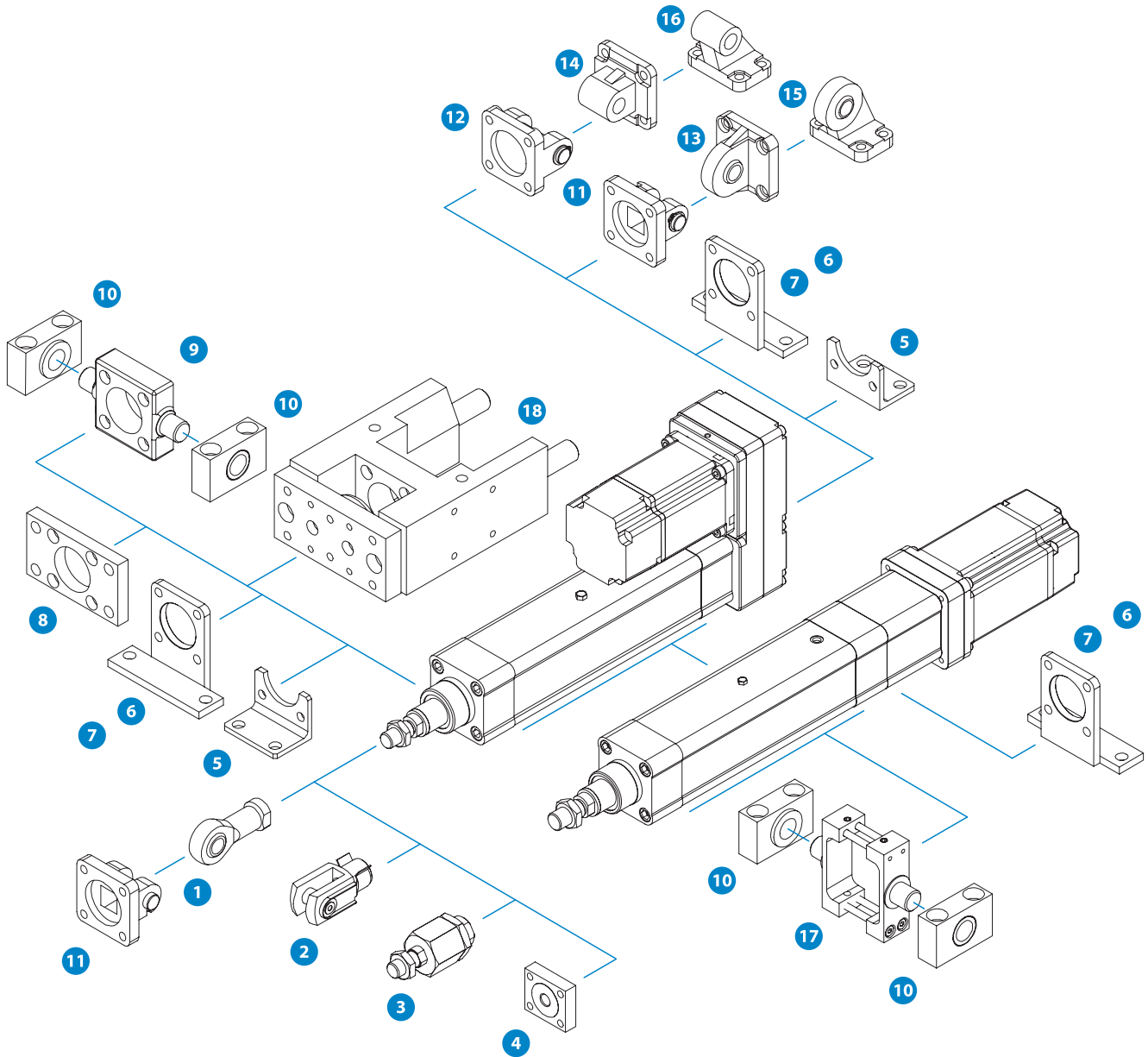

Figure 7: Accessories - overview

Page	13	14	15	16	17	18	19
Piston rod accessories	1 2 3 4						
Mounting attachment accessories		5 6 7 8 9 10 11 12 13 14 15 16 17					
Guiding unit							18

Table 2: Accessories - overview





For information about materials, dimensions and the maximum permissible loads of the accessories, see the catalogue UNIMOTION Electric cylinder PNCE.



Mounting accessories are not pre-assembled to the electrical cylinder in the factory before shipment.

Permissible loads

-  For the values of the maximum permissible axial load, lateral load, drive torque, travel and rotational speed and acceleration please see our catalogue UNIMOTION Electric cylinder PNCE.
-  Overloading the electric cylinder can lead to the product being damaged.
-  The piston rod must not be subjected to torsional moment. In the case of the presence of any torsional loads, the GUH guiding unit might be used, see Figure 8.

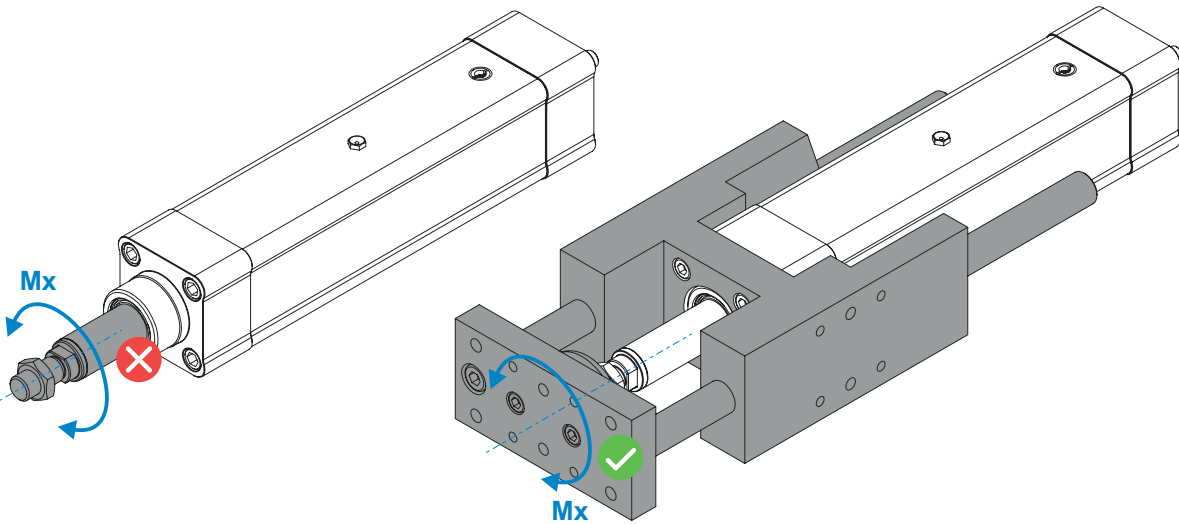



Figure 8: Piston rod subjected to torsional moment M_x .

-  In the case of mounting the piston rod accessories (see Table 2) the piston rod must not be subjected to torsion when tightening and loosening the hex nut. In order to avoid torsion, use one wrench to hold the piston rod accessory in proper position, then tighten or loosen the hex nut with the second wrench, see Figure 9.

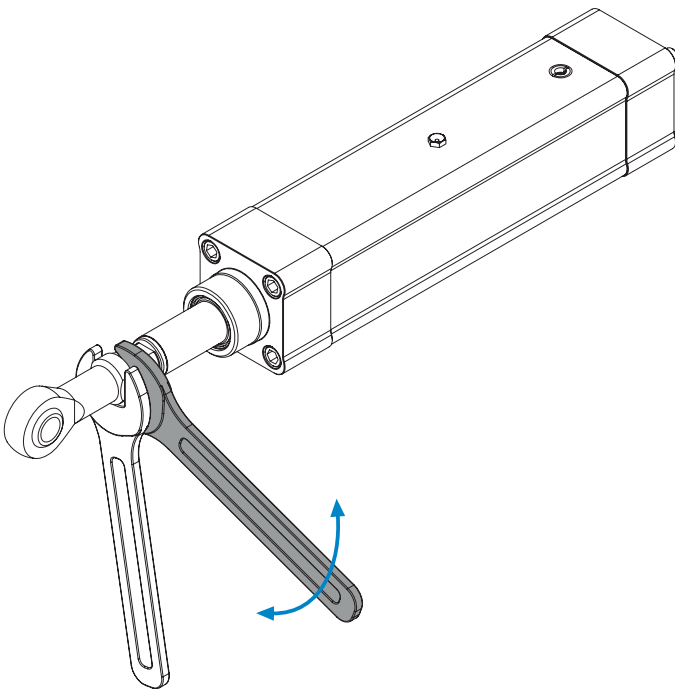



Figure 9: Tightening and loosening the hex nut to mount the piston rod accessory.

-  In the case of the ZKCE mounting attachment accessory, different tightening torques for the screws as are presented in Table 1, must be used, see Figure 10.
-  For tightening torques for the screws of the ZKCE mounting attachment accessory see the catalogue UNIMOTION Electric cylinder PNCE.

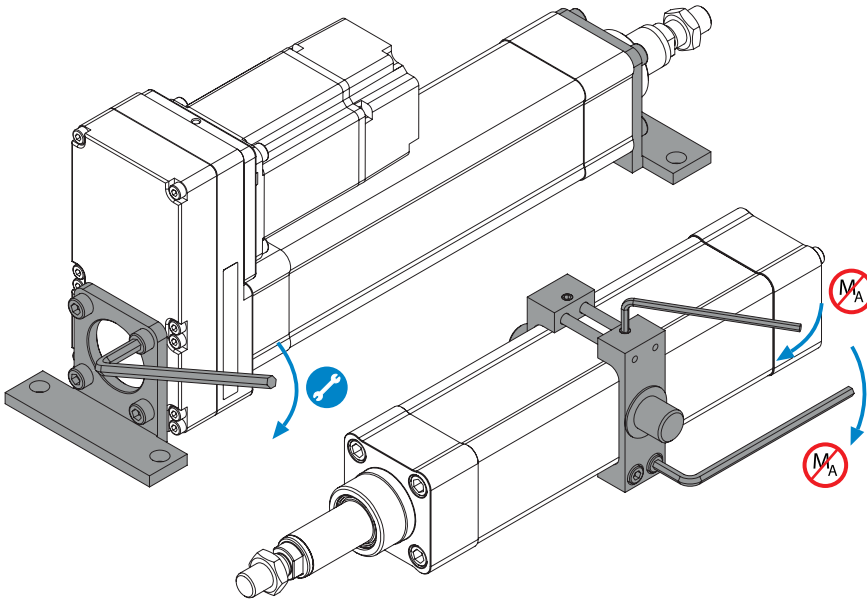
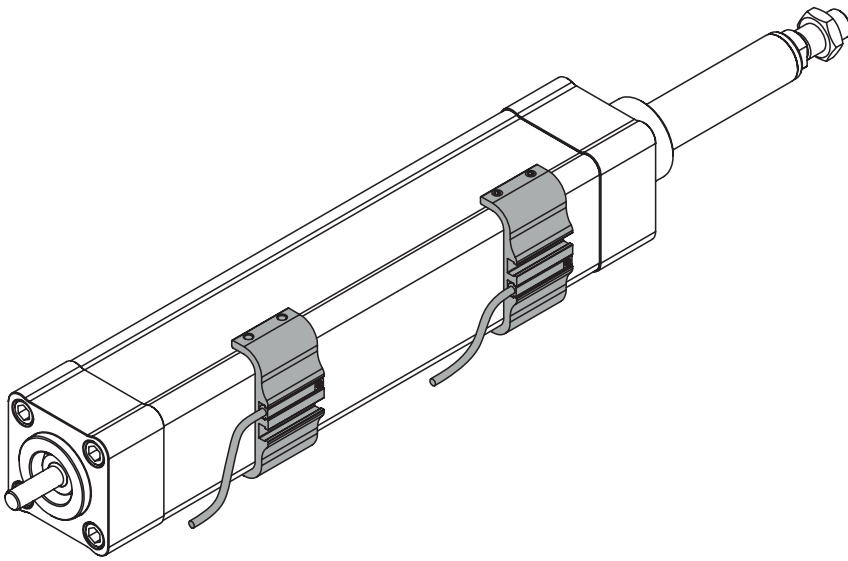
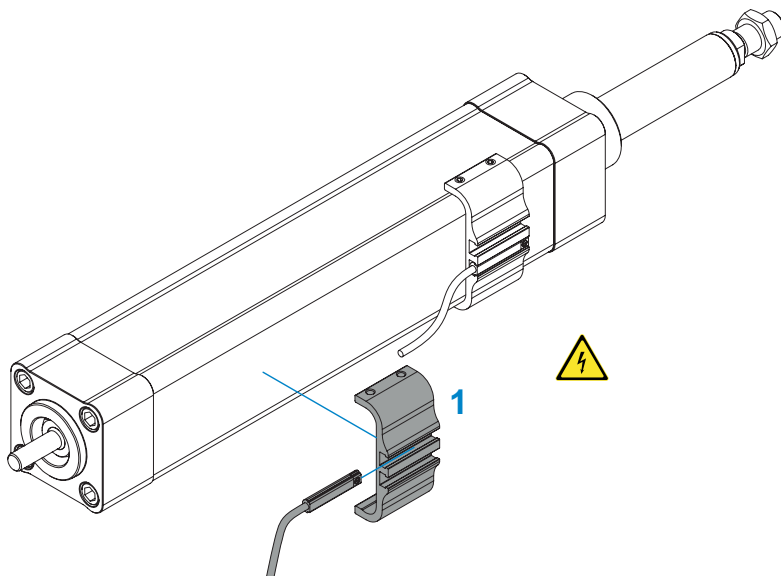

Figure 10: Tightening the screws of the mounting attachment accessories.

MAGNETIC FIELD SENSOR - REED SWITCH



STEP 1 and 2



STEP 1: The magnetic field sensor must first be mounted on the sensor holder **1**.



i Tighten the screw of the magnetic field sensor - REED switch with a tightening torque of max. 0,6 Nm.

STEP 2: Place the sensor holder **1** together with the magnetic field sensor on the electric cylinder profile, see Figure 12.

i For INFO about slots and dimensions of the sensor holder **1** see catalogue UNIMOTION Electric cylinder PNCE.

i The sensor holder can be placed on both sides of the electric cylinder profile.

Figure 11: Step 1 and 2.

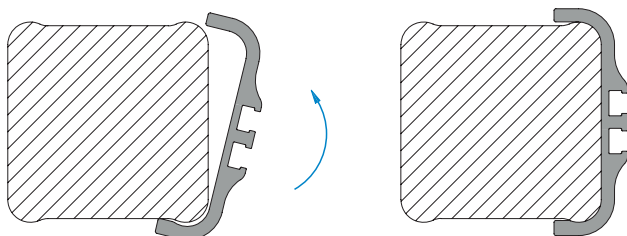

Figure 12: Placing the sensor holder on the electric cylinder profile.

STEP 3 and 4

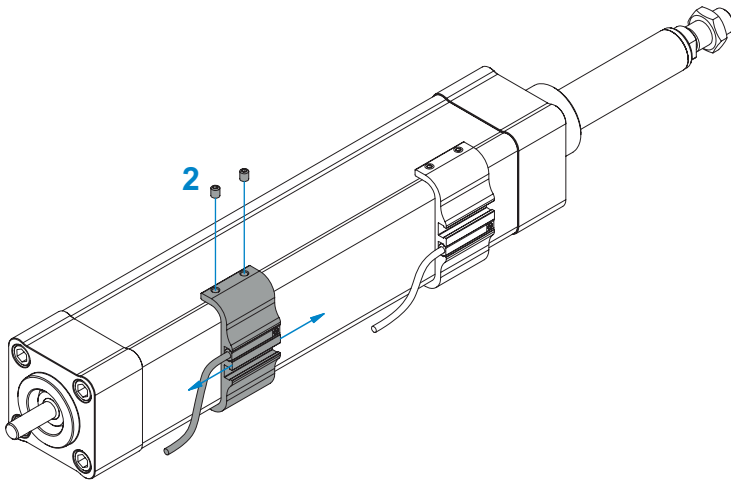



Figure 13: Step 3 and 4.

STEP 3: Adjust the sensor holder 1 together with the magnetic field sensor to the desired position. The positions of the magnets can be found in Table 3.

STEP 4: Tighten the screws of the sensor holder 2 (with a tightening torque of max. 1,0 Nm) to clamp the sensor holder 1 onto the electric cylinder profile. 

PNCE	Position of the magnets [mm]		LP [mm]
32	Piston rod position + 63,0	LP - E + 55,0	Piston rod position + E + 8,0
40	Piston rod position + 75,0	LP - E + 65,0	Piston rod position + E + 10,0
50	Piston rod position + 98,0	LP - E + 86,0	Piston rod position + E + 12,0
63	Piston rod position + 86,0	LP - E + 74,0	Piston rod position + E + 12,0

Table 3: Position of the magnets.

E	Extended piston rod	[mm]
---	---------------------	------

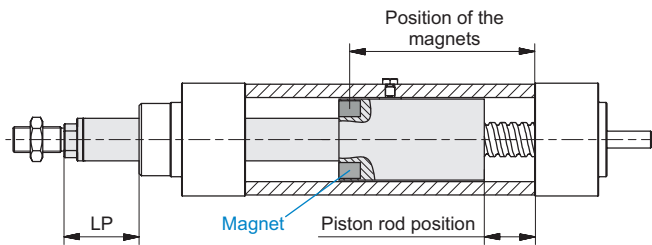
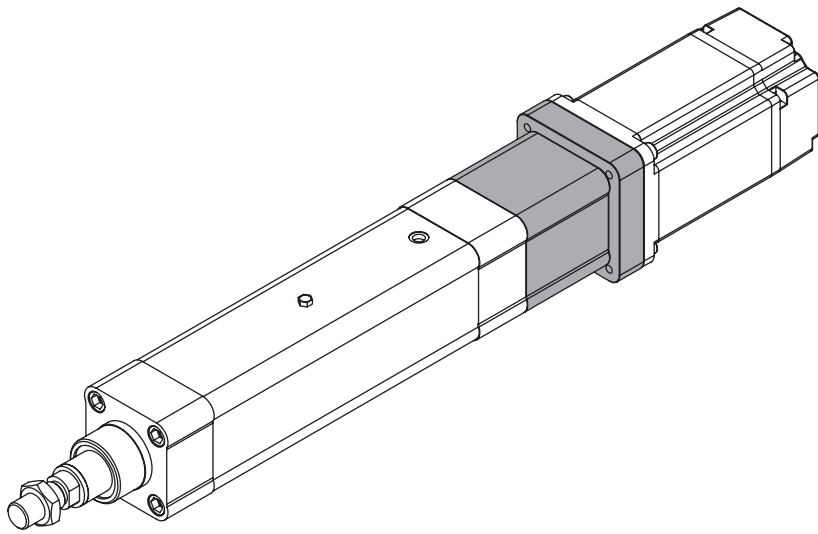

Figure 14: Position of the magnets.

i The position of the magnets can be calculated using the Piston rod position or distance LP, see Figure 14.

i $0 \text{ mm} \leq \text{Piston rod position} \leq \text{Absolute stroke}$

MOTOR ADAPTER WITH COUPLING



i The maximum speed and the maximum torque of the motor must not exceed the limits of the electric cylinder - PNCE and coupling.

📖 For the values of the speed and torque please see our catalogue UNIMOTION Electric cylinder PNCE



Assembly video

Parts list

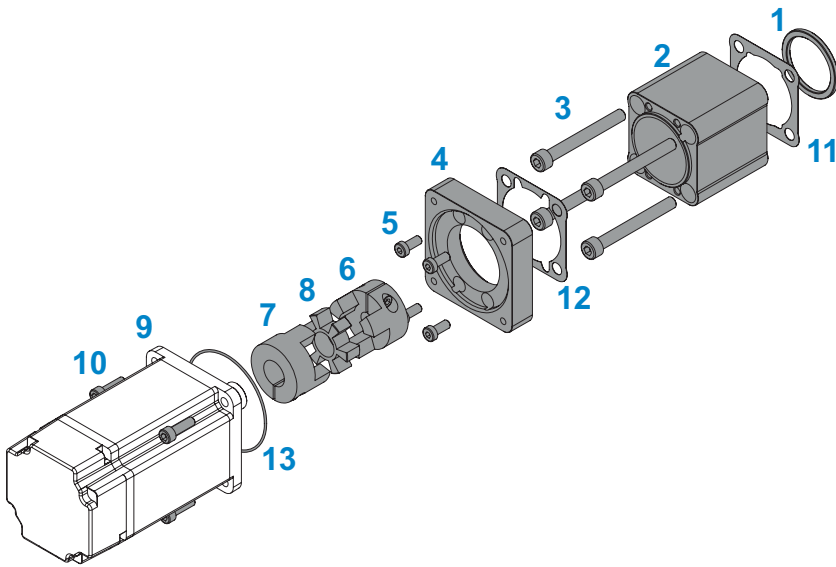

- 1 - Centring ring
 - 2 - Motor adapter housing
 - 3 - The motor adapter housing screw
 - 4 - Motor flange
 - 5 - The motor flange screw
 - 6 - Hub 1
 - 7 - Hub 2
 - 8 - Elastomer insert
 - 9 - Motor
 - 10 - The motor screw
 - 11 - Seal of the PNCE
 - 12 - The motor flange seal
 - 13 - The motor O ring seal
- elastomer coupling
- seals for the IP65CR protection

Figure 15: Parts list.

STEP 1, 2 and 3

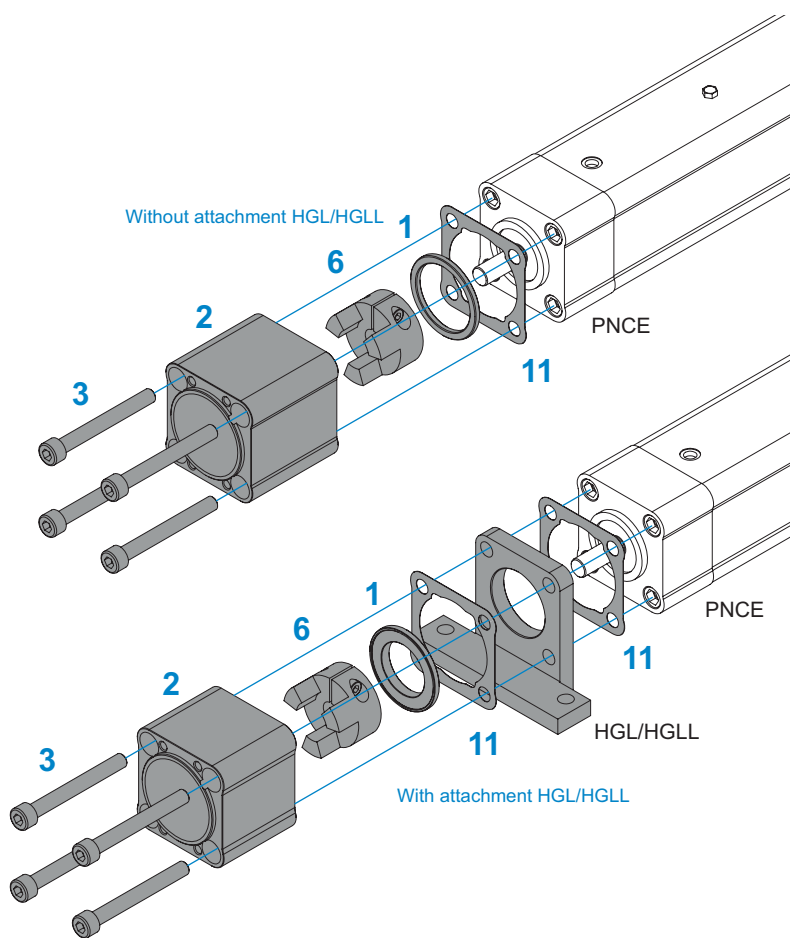

Figure 16: Step 1, 2 and 3.

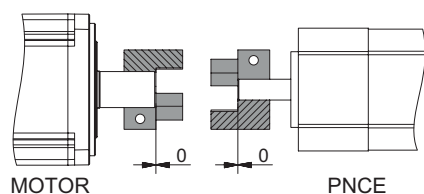

Figure 17: Coupling hubs and journals alignment.

STEP 1 (without attachment HGL/HGLL): In the case of the IP65CR protection the seal of the PNCE **11** must be placed on the drive cap of the electric cylinder - PNCE. The centring ring **1** must be fitted on the drive cap of the electric cylinder - PNCE.

STEP 1 (with attachment HGL/HGLL): In the case of the IP65CR protection the seal of the PNCE **11** must be placed on the electric cylinder - PNCE drive cap. The attachment HGL/HGLL must be fitted on the drive cap of the electric cylinder - PNCE. In the case of IP65CR protection the seal of the PNCE **11** must be placed on the attachment HGL/HGLL. The centring ring **1** must be fitted on the attachment HGL/HGLL.

i Some motor adapters don't have the centring ring **1**.

STEP 2: Place the coupling hub **1 6** on the drive journal of the PNCE. Ensure that the coupling hub **1 6** and the drive journal of the PNCE are correctly aligned, see figure 16. Tighten the coupling hub screw **1 6** with the coupling tightening torque.

i For the coupling tightening torque please refer to our catalogue UNIMOTION Electric cylinder PNCE.

STEP 3 (without attachment HGL/HGLL): Mount the motor adapter housing **2** on the drive cap of the PNCE using the screws of the motor adapter housing **3**.

STEP 3 (with attachment HGL/HGLL): Mount the motor adapter housing **2** on the attachment HGL/HGLL using the screws of the motor adapter housing **3**.

i For the tightening torques for the screws please refer to Table 1.

STEP 4 and 5

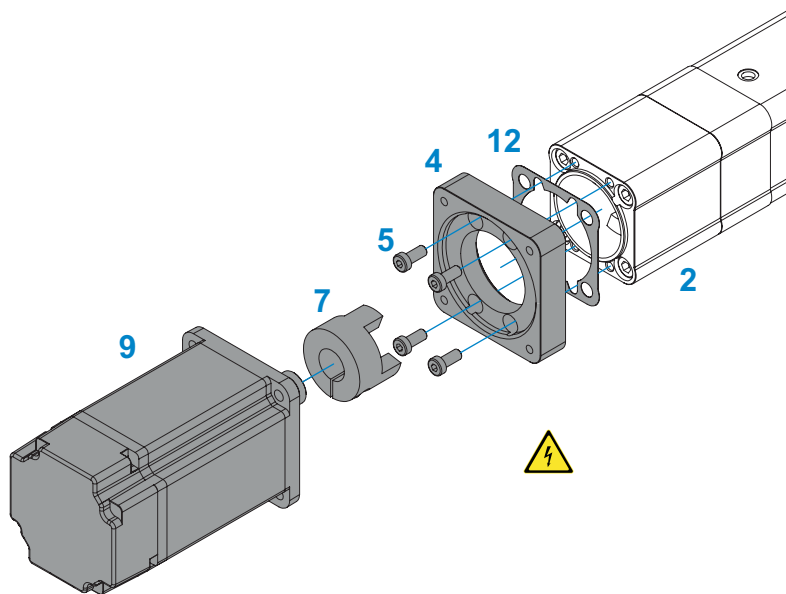

Figure 18: Step 4 and 5.

STEP 4: In the case of the IP65CR protection the seal of the motor flange **12** must be placed on the motor adapter housing **2**.

Mount the motor flange **4** onto the motor adapter housing **2** and tighten the screw of the motor flange **5**.

STEP 5: Place the coupling hub **2 7** on the motor journal. Ensure that the coupling hub **2 7** and the motor journal are correctly aligned, see Figure 18.

Tighten the screw of the coupling hub **2 7** with the coupling tightening torque.

- i** For the coupling tightening torque please refer to our catalogue UNIMOTION Electric cylinder PNCE.

STEP 6 and 7

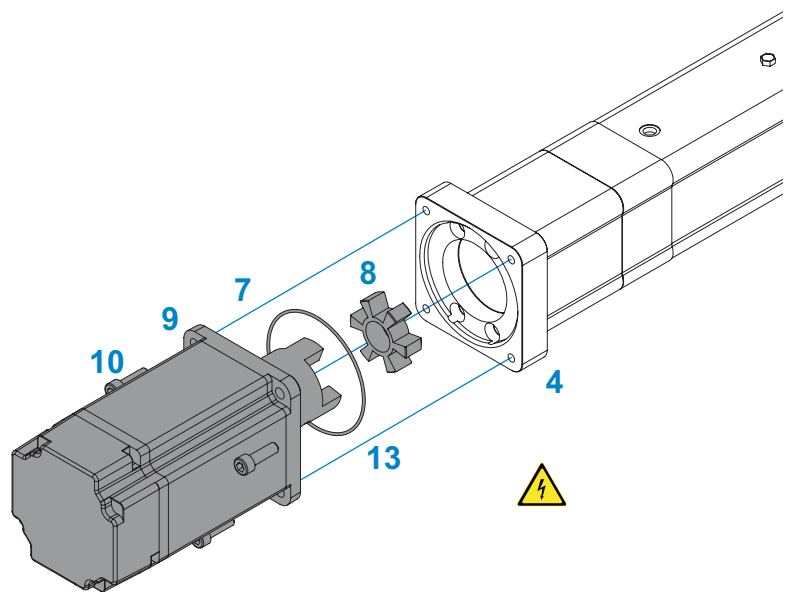

Figure 19: Step 6 and 7.

STEP 6: In the case of the IP65CR protection the O ring seal of the motor **13** must be fitted on the motor **9**. Insert the elastomer insert **8** into the coupling hub **2 7**.

STEP 7: Mount the motor **9** on the motor flange **4** with screw of the motor **10** and join the coupling hubs together at the same time.

- i** For the tightening torques for the screws please refer to Table 1.
- i** Before the initial start-up, check if everything is OK:
 - electrical wiring
 - mounted elements
 - tightened screws.

STEP 8

STEP 8: To dismantle the motor adapter - VK, take precautions, such as turning off the power supply and prevent the piston rod from dropping, if it is in a vertical position.

To dismantle the VK properly, look at the mounting procedure.

MOTOR SIDE DRIVE WITH TIMING BELT

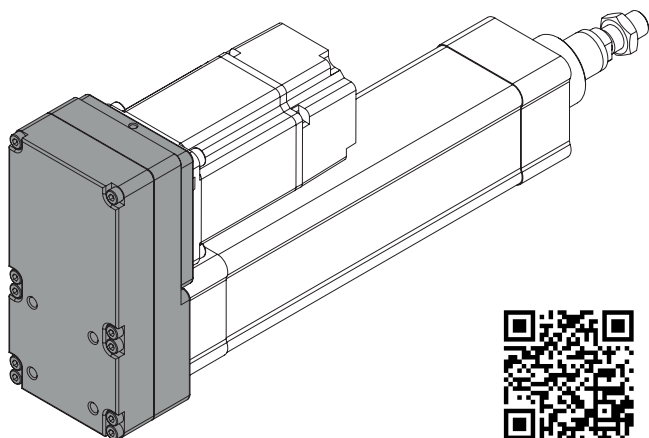

Assembly video

i The maximum speed and the maximum torque of the motor must not exceed the limits of the electric cylinder - PNCE and Motor side drive - MSD. For the values of the speed and torque, please see our catalogue UNIMOTION Electric cylinder PNCE.

Recommended tightening torques for screws of the self locking device

	M2,5	M3	M4	M5	M6	M8
$M_{A, max}$ [Nm]	1,2	2,1	4,9	9,7	17	41

Table 4: Recommended tightening torques for screws of the self locking device.

Identification label of the motor side drive

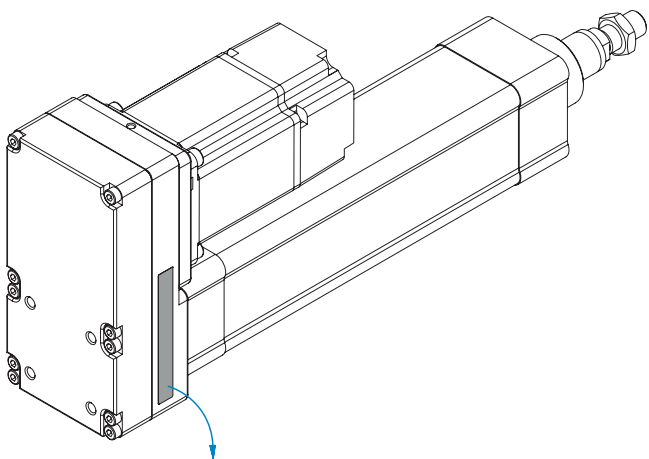

- 1 - ID number
- 2 - Manufacturing date of the motor side drive
- 3 - Maximum radial load on the shaft - pretensioning load F_{max}^*
- 4 - Type of the motor side drive (ordering code without motor dimensions)

* This is the load which is generated by the correct pretension of the belt - using the belt pretensioning unit. This load, which is linearly dependent on the maximum drive torque $M_{p, MSD}$, needs to be reduced in accordance with the capabilities of the motor.

- i** In the case of ordering additional or replacement parts for the motor side drive all data must be given from the identification label.
- i** The label must be fully visible and must ensure compliance with all the instructions contained on it. Damaged or illegible labels must be replaced.

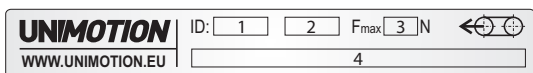

Figure 20: Identification label of the motor side drive.

Parts list

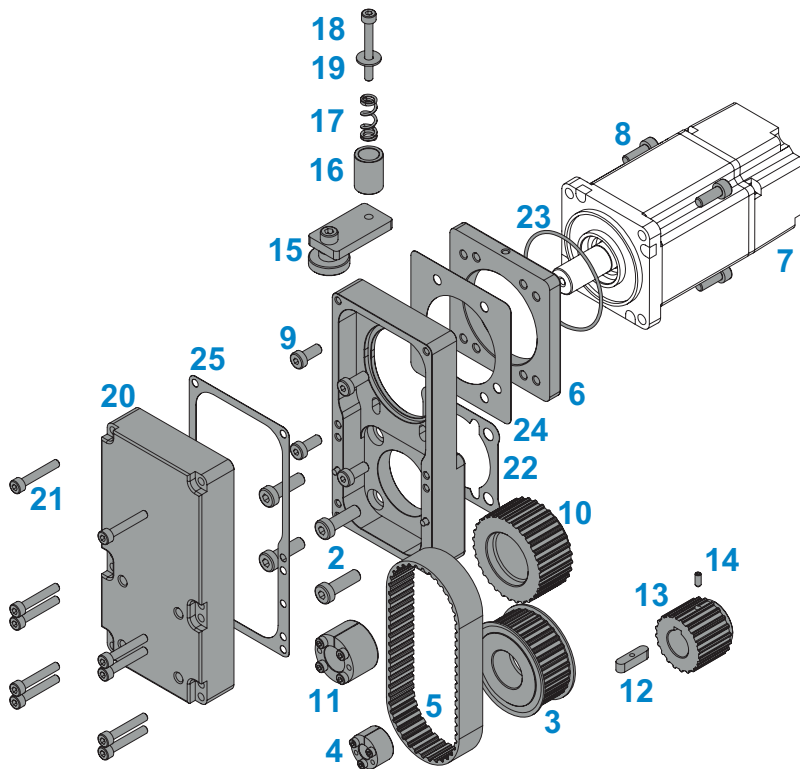

Figure 21: Parts list.

- 1 - Motor side drive housing
- 2 - Screw of the housing
- 3 - PNCE belt pulley
- 4 - Self locking device
- 5 - Toothed belt
- 6 - Tensioning plate
- 7 - Motor
- 8 - The motor screw
- 9 - The tensioning plate screw
- 10 - Motor belt pulley with clamping set
- 11 - Self locking device with keyway
- 12 - Keyway
- 13 - Motor belt pulley with keyway
- 14 - The keyway set screw
- 15 - Clamping plate
- 16 - Pretensioning limiter
- 17 - Spring
- 18 - Pretensioning screw
- 19 - Plain washer
- 20 - MSD cap
- 21 - The MSD cap screw
- 22 - The PNCE seal
- 23 - The motor O ring seal seals for the IP65CR protection
- 24 - The tensioning plate seal
- 25 - The MSD cap seal

STEP 1 and 2

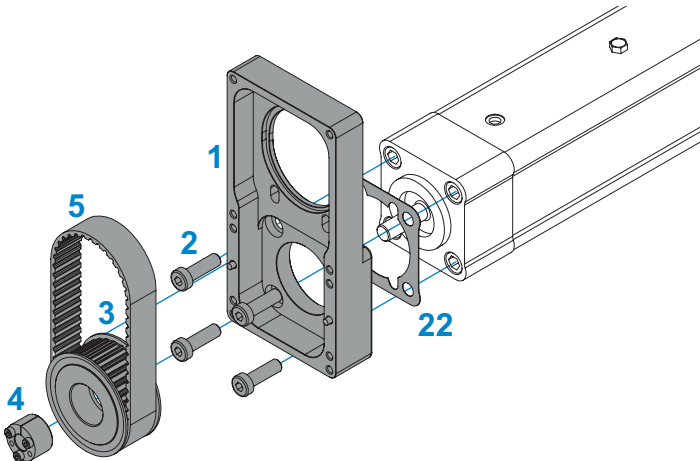

Figure 22: Step 1 and 2.

STEP 1: In the case of the IP65CR protection the seal of the PNCE **22** must be fitted on the drive cap of the PNCE.
The housing of the motor side drive **1** must be mounted and screwed (using **2**) on the drive cap of the electric cylinder - PNCE. The housing can be mounted in any way - UP, DOWN, RIGHT or LEFT.

STEP 2: After the housing **1** has been mounted on the electric cylinder, the PNCE belt pulley **3** with the self locking device **4** and the toothed belt **5** must be fitted on the drive journal of the PNCE.
Adjust the clearance as is shown in Figure 22 and Table 5. Tension the self locking device **4**.

Clearance

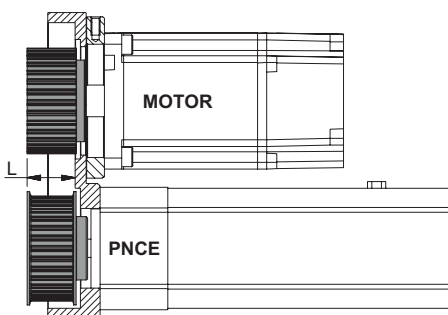

Figure 23: Clearance.

PNCE	Type	Gear ratio	Distance L [mm]
32	T0	1	16,0
		1	14,5
	T1	1,5	14,5
40	T1	1	21,0
		1,5	21,0
	T2	1	21,0
63	T1	1	38,0
		2	38,0
50	T1	1	31,5
		1,5	31,5
	T2	1	31,0
		2	31,0

Table 5: Clearance.

i Distance L is equal for both PNCE and the motor belt pulley.

i For the tightening torques for the screws please refer to Table 1.

STEP 3, 4 and 5

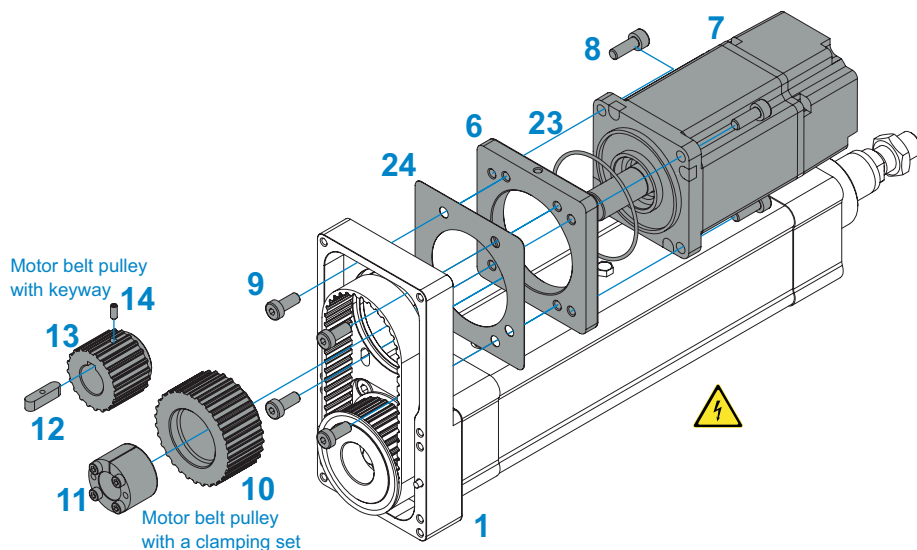

Figure 24: Step 3, 4 and 5.

STEP 3: In the case of IP65CR protection the O ring seal of the motor **23** must be fitted on motor **7**.
Mount the motor **7** onto the tensioning plate **6** and tighten the screws of the motor **8**.

STEP 4: Mount the tensioning plate together with the motor (and with the seal of the tensioning plate **24** in the case of the IP65CR protection) onto the housing of the motor side drive **1** and lightly tighten the screws of the tensioning plate **9**. Make sure that the movement of the tensioning plate **6** is unrestricted.

STEP 5: When the tensioning plate is mounted onto the housing, mount the motor belt pulley **10** with the self locking device **11** onto the motor journal in the case of the motor belt pulley with a clamping set or mount the motor belt pulley **13** with the keyway **12** onto the motor journal in the case of the motor belt pulley with a keyway.
Adjust the clearance as is shown in Table 5.
Tension the self locking device **11** (for tightening torques please refer to table 1) in the case of the motor belt pulley with the clamping set or tighten the set screw of the keyway **14** in the case of the motor belt pulley with a keyway.

STEP 6, 7 and 8

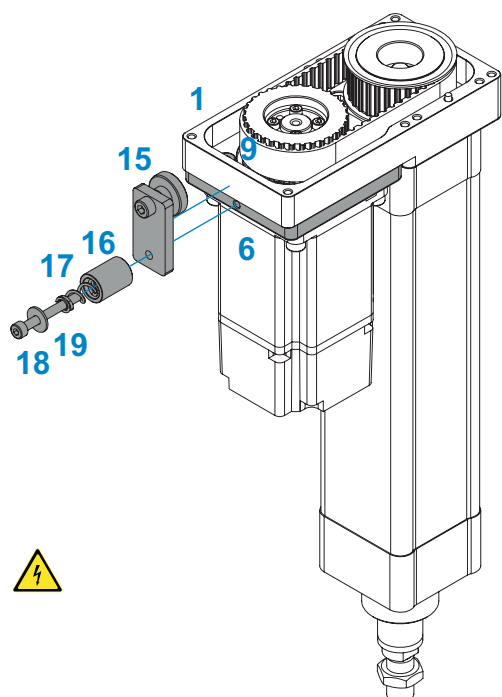

Figure 25: Step 6, 7 and 8.

STEP 6: Place the housing of the motor side drive (together with the PNCE and the motor) in a horizontal direction.

STEP 7: Mount the clamping plate **15** onto the edge of the housing of the motor side drive **1**, see figure 26.
Screw the pretensioning screw **18** with a plain washer **19** and spring **17** through the pretensioning limiter **16** and the clamping plate **15** into the tensioning plate **6**.
Tighten the pretensioning screw **18** to obtain zero-clearance between the pretensioning limiter **16** and the plain washer **19**, see Figure 27.

STEP 8: After the belt pretensioning procedure tighten the screws of the tensioning plate **9**.

i For the tightening torques for the screws please refer to Table 1.

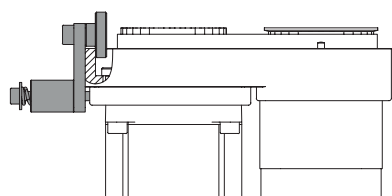

Figure 26: Mounting of the belt pretensioning unit.

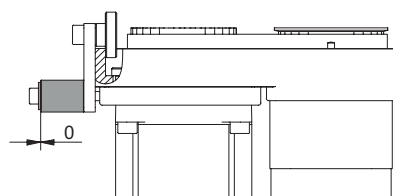

Figure 27: Belt pretensioning procedure.

STEP 9 and 10

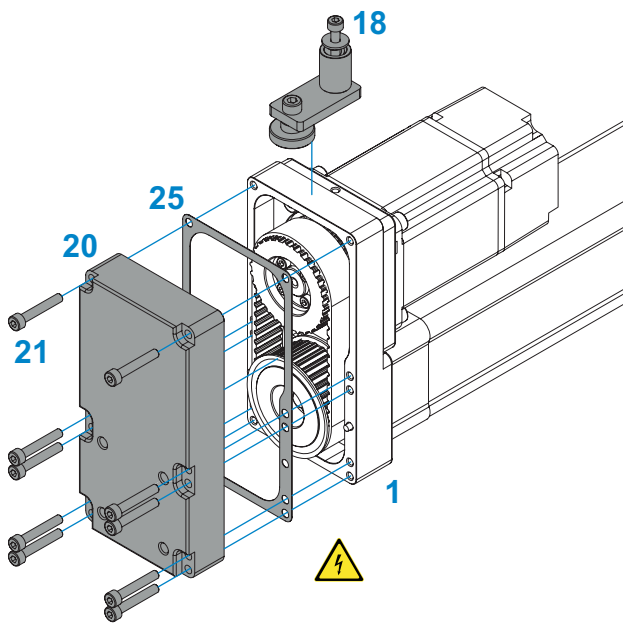

Figure 28: Step 9 and 10.

STEP 9: Loosen the pretensioning screw **18** and remove the belt pretensioning unit.

STEP 10: In the case of IP65CR protection the seal of the MSD cap **25** must be fitted on the housing of the motor side drive **1**. Mount the MSD cap **20** on the housing of the motor side drive **1**. Tighten the screws of the MSD cap **21**.

- i** Before the initial start-up, check if everything is OK:
- electrical wiring
 - mounted elements
 - tightened screws
 - correct tensioning of the belt.

STEP 11

i Take care when loosening the screws of the tensioning plate when the toothed belt is tensioned.



STEP 11: To dismantle the motor side drive - MSD, take precautions, such as turning off the power supply and prevent the piston rod from dropping, if it is in a vertical position. To dismantle the MSD properly, look at the mounting procedure.

MAINTENANCE

i For each electric cylinder the basic lubrication is done in the factory before shipment. All the bearings have been lubricated for life and do not require any additional lubrication under normal operating conditions. Only the ball screw drive requires maintenance.

Lubrication of the ball screw drive

The ball screw drive lubrication is done via a lubricating nipple DIN 3405 D at the centre of the cylinder profile.

Lubricant

Recommended grease for the lubrication:
 Lubcon TURMOGREASE LC 802 EP (K HC P 2/3 N -30)

i For lubrication and re-lubrication of the electric cylinders a grease lubricant must only be used! Do not use grease which contains any solid parts!

Lubricant quantities and intervals

PNCE	Ball screw	Travel path	Grease - re-lubrication quantity
	d×l [mm]	[km]	[cm³]
32	12x5	250	0,6
	12x10	500	0,6
40	16x5	250	1,1
	16x10	500	1,4
	16x16	800	1,8
50	20x5	250	1,6
	20x10	500	2,3
	20x20	1000	3,4
	20x50	2500	5,0
63	25x5	250	2,3
	25x10	500	2,8
	25x25	1250	4,7

i The stated lubrication intervals in the table on the left are sufficient for normal operating conditions. If you have special operating systems please contact us. The lubrication intervals are every 500 operating hours or after the specified travel path stated in the table on the left. It depends on which value is reached first.

Table 6: Lubricant quantities and intervals.

Lubrication position

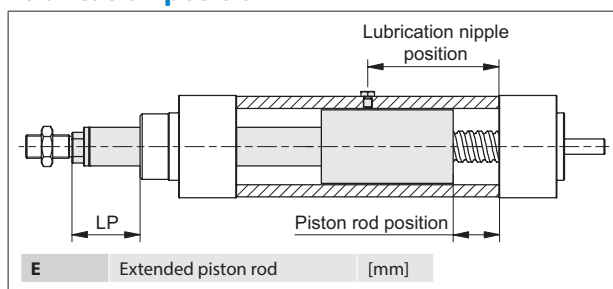

Figure 29: Lubrication position.

PNCE	Ball screw	Lubrication nipple position	Piston rod position	LP
	d×l [mm]	[mm]	[mm]	[mm]
32	12×5, 12×0	Abs. stroke / 2 + 38,0	Abs. stroke / 2 - 9,0	Abs. stroke / 2 + E - 1,0
40	16×5, 16×10, 16×16	Abs. stroke / 2 + 42,0	Abs. stroke / 2 - 10,5	Abs. stroke / 2 + E - 0,5
	20×5, 20×10, 20×20	Abs. stroke / 2 + 53,5	Abs. stroke / 2 - 22,0	Abs. stroke / 2 + E - 10,0
20×50	Abs. stroke / 2 - 5,0		Abs. stroke / 2 + E + 7,0	
63	25×5, 25×10	Abs. stroke / 2 + 47,5	Abs. stroke / 2 - 13,5	Abs. stroke / 2 + E - 1,5
	25×25		Abs. stroke / 2 - 4,0	Abs. stroke / 2 + E + 8,0

Table 7: Lubrication position.

The lubrication nipple on the aluminum profile of the electric cylinder allows easy re-lubrication of the ball screw drive. To achieve the lubrication position the piston rod must be moved from the end position into the position (Piston rod position) shown in the table above. The same position is achieved when the distance LP is obtained. Apply grease to the ball screw drive using the lubrication nipple. Make sure that the entire quantity of grease is used at once. Move the piston rod three times over the entire travel range after the lubrication process.

Normal operating conditions

Temperature	+10°C ~ +30°C
Load	≤ 0,2 C
n (RPM)	100 min ⁻¹ ≤ n ≤ 2500 min ⁻¹
Stroke	> minimum stroke s _{min}
Version	Standard (S)

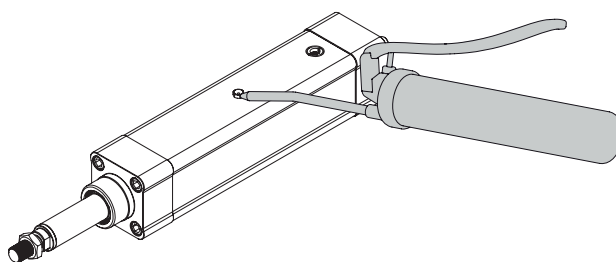

Figure 30: Lubrication of the ball screw drive.

Cleaning of the electric cylinder

- i** Use only fresh water for cleaning the product, otherwise please contact us.
- !** During the cleaning procedure the water must be prevented from getting into the electric cylinder.

START-UP

Before the initial start-up, check if everything is OK:

- electrical wiring
 - mounted elements
 - i** - tightened screws
 - correct tensioning of the belt
 - limit switches
 - operating conditions (see section **Operating conditions**)
 - travel range of the piston rod
- i** For the values of the maximum permissible axial load, lateral load, drive torque, travel and rotational speed and acceleration please see our catalogue UNIMOTION Electric cylinder PNCE.
- !** Overloading the electric cylinder can lead to the product being damaged.
 - !** Before any operation, possible damage to the product and injuries caused by the electrical current or moving parts must be prevented.
 - !** When running the electric cylinder for the first time, move the piston rod at a slow speed (~ 10 mm/sec) over the entire travel range. Make sure that over the entire travel range there are no physical stop limits.

ASSEMBLY OF THE PNCE - OVERVIEW

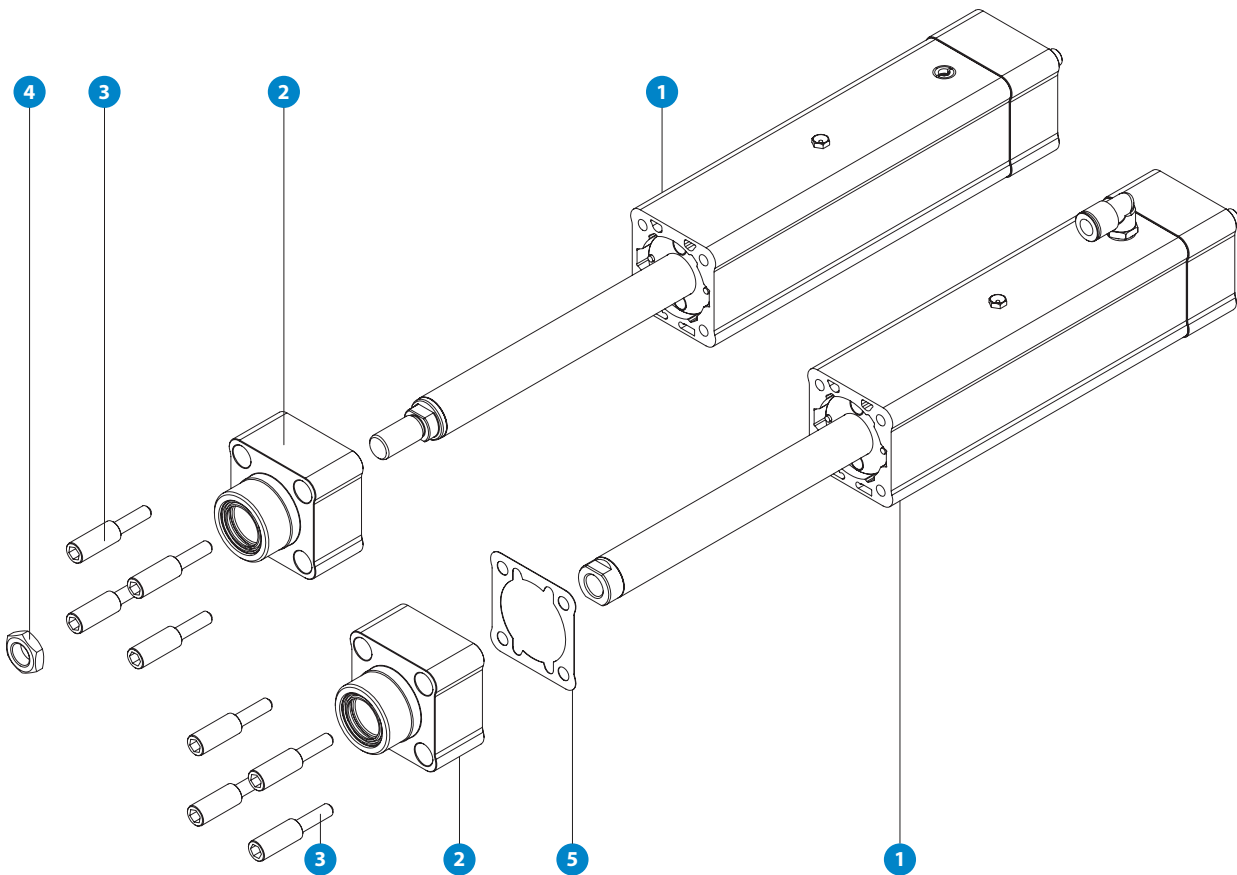





Figure 31: Assembly of the PNCE.

ITEM	QTY	PART NAME
1	1	PNCE main assembly
2	1	Front cap assembly
3	1	Set of four screws of the front cap
4	1	Hex nut
5	1	Seal of the PNCE

- i** In case of ordering additional or replacement parts for the electric cylinder all data must be given from the identification label.

REPLACEMENT OF THE ASSEMBLIES

 Before any operation make sure that the electric cylinder is disconnected from the power grid to prevent possible injuries caused by the electrical current or moving parts. 

 Before replacing the assemblies of the PNCE, the mounting accessories together with the MSD or VK, must be removed first. For dismounting please see section **Mounting**.

Replacing the front cap assembly

STEP 1: In case of PNCE with option 1 = standard (see ordering code), the hex nut **4** must be removed. 

STEP 2: Loosen all four screws of the front cap **3** and remove them.

STEP 3: Remove the front cap assembly **2**.

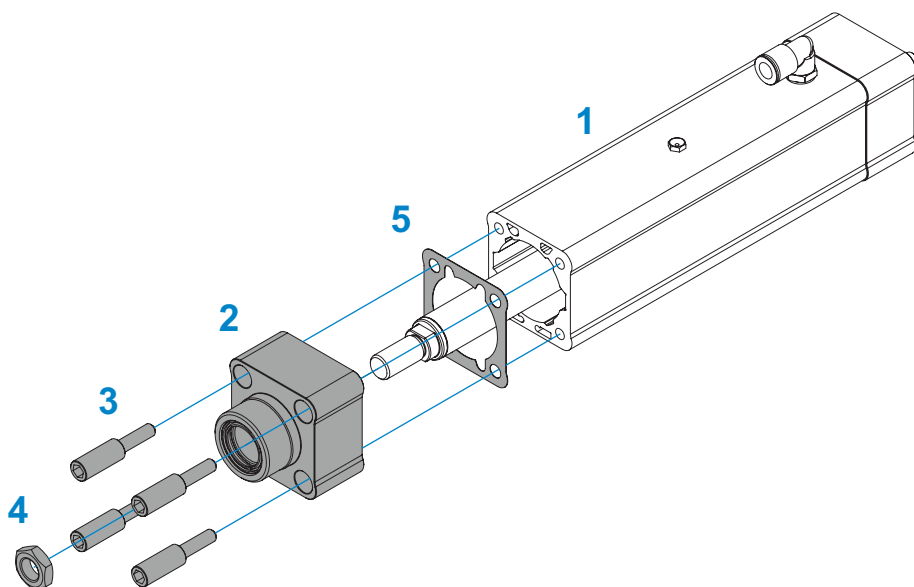



STEP 4: In the case of IP65 protection check if the seal of the PNCE **5**, which is placed between the cylinder profile and the front cap, is damaged. If so, the seal of the PNCE **5** must be replaced with a new one.

 It is recommended to replace the seal of the PNCE **5** with the new one when replacing the front cap assembly **2** to ensure optimal sealing.

STEP 5: Replace the front cap assembly **2** with the new one and push it on the piston rod to reach the cylinder profile.

STEP 6: Extend the piston rod to the end position. Mount the front cap assembly **2** on the PNCE main assembly **1**. Align the front cap assembly **2** with the PNCE main assembly **1** before tightening the screws of the front cap **3**. In case of damage to the screws of the front cap **3** they must be replaced with new ones. 

 Before using the screws of the front cap **3** they need to be cleaned first and then glued (Loctite 243).

STEP 7: In the case of a PNCE with option 1 = standard (see ordering code), the hex nut **4** needs to be placed back on the piston rod end. 

Replacing the PNCE main assembly

 Replacing the PNCE main assembly **1** follows the same replacement procedure as is described in the subsection **Replacing the front cap assembly**. Take into consideration that the only difference in this case is to replace the PNCE main assembly **1** with the new one.

UNIMOTION

Unimotion GmbH
Waldstrasse 20
D - 78736 Epfendorf

Tel: +49 (0) 7404 930 85 60
Fax: +49 (0) 7404 930 85 61

www.unimotion.de
e-mail: vertrieb@unimotion.de